

Kathie Gannon

Presiding Officer



Board of Commissioners

- District 1 - Nancy Jester
- District 2 - Jeff Rader
- District 3 - Larry Johnson
- District 4 - Steve Bradshaw
- District 5 - Mereda Davis Johnson
- District 6 - Kathie Gannon
- District 7 - Gregory Adams

**DEKALB COUNTY GEORGIA
BOARD OF COMMISSIONERS
REGULAR MEETING
MARCH 28, 2017**

MEMBER PRESENT: Nancy Jester, Jeff Rader, Larry Johnson, Steve Bradshaw, Mereda Davis Johnson, Kathie Gannon, Gregory Adams

MEMBER ABSENT:

STAFF: Zachary Williams, Executive Assistant/Chief Operating Office, Barbara Sanders-Norwood, County Clerk, Andrew Cauthen, Communications Manager, O.V. Brantley, County Attorney, Viviane Ernstes, Deputy County Attorney

A. **INSPIRATIONAL** Ashley Wilcox
Atlanta Friends Meeting, Ministry and Worship Committee

PLEDGE OF ALLEGIANCE Commissioner Gregory Adams
District 7

B. COMMENTS FROM THE PUBLIC

The Public Comments portion of this meeting is reserved exclusively for comments from the public, and not for immediate reply. Statements made during the Public Comments portion do not necessarily reflect the Opinions of the Board or the Administration of DeKalb County Government.

The purpose of public comment is to allow the public to voice county-related requests, concerns or opinions during the Commission meeting. Speakers will only have the opportunity for one public comment per meeting. Each speaker must complete a speaker card and present it to the clerk before the beginning of the public comment portion of the meeting. The clerk will accept cards on a first-come, first-served basis. Speakers who are residents of DeKalb County shall be allowed to speak before residents of other counties are allowed to speak. Once the public comment portion of the meeting begins, speaker cards will no longer be accepted. Speakers will be allowed to speak for three minutes each and public comment shall not exceed 30 minutes in length. When the buzzer sounds to indicate that time has run out, the speaker will be expected to immediately cease speaking and to yield the podium. Those who submitted speaker cards but did not speak because of the time allotment will be allowed to speak first at the next regularly scheduled Commission meeting without regard to residence. Speakers should always talk directly into the microphone and begin by stating their name,

full address and the name of any organization they represent. Abusive, profane or derogatory language, holding up signs, clapping and yelling will not be permitted. A show of hands or quietly standing will be permitted to show support for or opposition to a speaker's position.

1. Charles McCorkle, 4225 Snapfinger Woods Drive, Decatur, Ga. 30035 – Commended the DeKalb County Law Dept. in identifying discrepancies in the liquor licensing package for the Lemon Drop Sports Bar.
2. Faye Coffield, 3261 Chaparral Way, Lithonia, Ga. 30038 – Commented on the Board of Commissioner's request for a pay raise when pay raises have not been approved for Police, Fire, & 911. Also expressed support for a 20% pay raise for Police, Fire, & 911.
3. Joe Arrington, 466 S. Rays Road, Stone Mountain, Ga. 30083 – Expressed opposition to pay raises for Commissioners without giving a raise to Public Safety. Also commended Commissioner Jester for opposing the Commission pay raise.
4. Jessica Whimper, 3437 Kingsbrooke Way – Representing the Columbia High School's P.I.L.O.T. program, Preparing Innovative Leaders of Tomorrow. Spoke about the lack of scholarship choices among fellow high achieving graduating seniors.

C. PRESENTATIONSPurchasing Month

DeKalb Marshal Steve Mann

Boys & Girls Club Week

D. 10:00 A.M. PUBLIC HEARING

Citizens may speak for or against an item that is considered by law to be a zoning ordinance and each side will have ten minutes to presents its case. Citizens may also speak for or against an item that is placed on the public hearing agenda but is not a zoning ordinance. In that case, each side will have five minutes to present its case. In the event there is more than one speaker per side, speakers must divide their time in order to complete their full presentation within the ten-minute time allotment, or the five-minute time allotment. When the buzzer sounds to indicate that time has run out, the speaker will be expected to immediately cease speaking and to leave the podium area. Prior to speaking, please complete a speaker card and present it when approaching the podium. If you have any documents for the Commissioners, please provide 10 copies when approaching the podium. Seven copies are for the Commissioners and the remaining copies are for the planning director, the county attorney and the clerk. Applicants or citizens speaking in favor of an item shall speak first and applicants in zoning ordinance cases shall have the right to reserve time for rebuttal. Opponents of a zoning ordinance item shall have no right of rebuttal. Once the citizens have finished speaking, staff shall make a recommendation for action to the commission. At this point, citizens are no longer allowed to speak unless called to the podium by an individual commissioner to answer questions or provide information. When speaking, always talk directly into the microphone and begin by stating your name, address and the name of any organization you represent. Abusive, profane or derogatory language will not be permitted. Holding up signs, clapping and yelling to show support for or opposition to a speaker will not be permitted, but a show of hands or quietly standing will be permitted to show support for or opposition to a speaker's position.

CEO

- D1. 2017 Budget Amendment 1 – Public Safety (*Deferred from the 2/28/17 Regular BOC Meeting – for public hearing; Assigned to the Finance, Audit & Budget and Employee Relations & Public Safety Committees – no official recommendation; Discussed during the 3/21/17 Employee Relations & Public Safety Committee – recommended a one-month deferral*)
- D2. 2017 Budget Amendment 6 – Removal of Budget Policies Until a Later Date (*Deferred from the 2/28/17 Regular BOC Meeting – for public hearing*)
Public Works – Transportation – Commission Districts 1 & 7
- D3. Street Light Petition- Reevely Lane (*Accepted to the Regular BOC Meeting Agenda*)
Public Works – Transportation – Commission Districts 3 & 7
- D4. Traffic Calming Petition- Cocklebur (between Columbia Parkway and Cocklebur Rd) (*Accepted to the Regular BOC Meeting Agenda*)
Public Works – Transportation – Commission Districts 5 & 7
- D5. Street Light Petition- Haynes Park Drive, Garden Glade Lane, Haynes Park Place, and Haynes Park Circle (*Accepted to the Regular BOC Meeting Agenda*)

E. APPEALS

E1. NONE

F. APPOINTMENTS

CEO

- F1. Appointment to the DeKalb County Department of Family and Children Services Board – Ms. Jane Wilkov, MD (*Deferred from the 11/15/16, 1/10/17, 2/14/17 & 3/14/17 Regular BOC Meetings; Discussed during the 3/15/17 Planning, Economic Development and Community Services Committee – recommended approval*)

110. Purchases – Change Order

CO1. Change Order No. 1 to Contract No. 14-902807 for Ethernet Dedicated Internet (Multi-year Contract): for use by the Department of Innovation and Technology (IT). Amount Not To Exceed: \$681,141.59 (*Accepted to the Regular BOC Meeting Agenda; Assigned to the County Operations Committee; Deferred from the 3/14/17 Regular BOC Meeting; Discussed during the 3/14/17 County Operations Committee meeting – recommended approval*)

J. COMMENTS FROM THE BOARD

1. **Commissioner Nancy Jester** – Thanked Animal Shelter and Lifeline for allowing her to visit some of the dogs. Also wanted to state that she met a woman from district 4 who is one of the first African American women to earn a PHD in Physics from the University of Georgia, and hopes to get her to speak at one of the Commission meetings.
2. **Commissioner Jeff Radar read the following comments –**

Thank you...

To Park Pride for a wonderful conference yesterday at the Atlanta Botanical Gardens. DeKalb County resident Barbara Marin received the Park Pride Inspiration Award for her work with the Friends of Springbrook Park. Barbara has led many volunteers to establish and beautify Springbrook Park from an overgrown vacant lot to a vibrant community park. Barbara's work in the county is an example of the good that can come from citizens working in concert with county staff and elected officials to bring about positive change in their communities. Thank you, Barbara!

Thanks also to the Clarkston High School Culinary Class for the wonderful meal preparation for seniors at the Central Senior Center last Thursday. This partnership between our youth and seniors of DeKalb County is encouraging as we are always better together!

Upcoming

- Saturday, March 25th join volunteers in Deepdene Park at 8:30am for a work day. Bring gloves and water bill.
- Mary Scott Native Woods Restoration Work Day will also take place this Saturday, March 25th from 1:00 – 3:00pm. Led by Georgia Native Plant Society volunteers, the focus will be to remove invasive species. Bring gloves and hand pruner.
- Olmsted Plein Air Invitational coming April 2nd thru April 9th One of the most prestigious plein air painting competitions in the United States, the Olmsted Plein Air Invitational includes expanded areas for artists to paint this year. From Piedmont Park to the Atlanta History Center, the Shops at Buckhead to Olmsted Linear Parks, competing artists will paint Atlanta landmarks. More information is at www.olmstedpleinair.com. Of special note, on Thursday, April 6th, artists will be painting in and around Decatur and on April 8th and 9th, artists will be in Olmsted Parks for the very popular quick paint competition.
- Library Happenings...

Fine Forgiveness program will take place April 3 through April 23, 2017. Library Director Alison Weissinger urges patrons to take advantage of the opportunity to bring in overdue items. The Fine Forgiveness program includes a waiver on the first \$10.00 owed and a 50-percent discount on the remaining balance for patrons owing \$100 or less. Patrons owing more than \$100 are asked to call Library Administration at 404.508-7190

3. **Commissioner Larry Johnson** – Thanked everyone who attended his mother’s home-going celebration as well as everyone for their prayer and support. Also thanked the Heart of South DeKalb for doing “walking clubs” around local parks to inform citizens of the various programs the parks have to offer. Informed citizens of clean-up on Candler road throughout the month of April, as well as mentioned the Single Parent Expo, that was held on the previous Saturday. Also mentioned the Opioid Summit on May 4th and urged citizens to sign up for the summit.

4. **Commissioner Steve Bradshaw read the following comments –**

Thank you Madam Presiding Officer...

Good Morning Everyone. First and Foremost I want to thank all of the Department Heads and employees of DeKalb County for their hard work and on-going dedication to this county.

I’d like to thank Miss Carrie Briscoe and the good folks in the Inverness Woods Community for inviting me to attend their Community Meeting on Wednesday March 22. I’d also like to thank Office B. C. Zellars from Code Enforcement for participating as well. He did a great job!

I’d also like to thank State Representative Michele Henson and the good folks at Pride Rings in Stone Mountain (PRISM) for inviting me to participate in their Community Meeting on Thursday March 23. Attendance at this meeting was excellent.

Other participants were Gordon Burkett from Beatification, Tonza Clark from Code Enforcement and John Kelley from Georgia Power.

I also want to thank our Tax Commissioner Irvin Johnson for affording me the opportunity to participate in a tax workshop for Seniors at Fire Station 25 last night.

I would like to commend my colleague Commissioner Gregory Adams for hosting the Hidden Figures Ceremony. It was an honor to be in presence so many remarkable women in DeKalb County.

It was an honor to attend the memorial service on Saturday afternoon for Diana Johnson, the mother of my colleague Commissioner Larry Johnson. Once again, I want to express how sorry I am for your loss.

I would like to remind everyone that the County Operations Committee will be meeting this afternoon at 2pm.

Of course you are always welcome to reach our team in the office:

Chief of Staff, Alesia Brooks 404-371-7031 adbrooms@dekalbcountyga.gov

Constituent Coordinator, Robin Detar 404-371-4749 rlidetar@dekalbcountyga.gov

Me srbradshaw@dekalbcountyga.gov

As always I want to thank the citizens of District 4 for trusting me with this responsibility. It

- 7. Commissioner Kathie Gannon** – Commended Commissioner Adams on the Hidden Figures event. Also gave condolences to Commissioner Larry Johnson. Mentioned the DeKalb CEO's launch of the DeKalb Works summer internship program for youth ages 14-24, on March 29th, as well as the launch of the DeKalb schools phase II clean-up. Reminded everyone that residents 60 and older can receive free tax assistance at DeKalb County Libraries, and also mentioned the Library fine forgiveness program. Reminded citizens to apply for the homestead exemption through the Tax Commissioner's office. Mentioned the DeKalb Youth Career Readiness Expo April 3rd and 4th, held at Georgia Piedmont Technical College. For more information, contact the WorkSource DeKalb program phone number listed on Commissioner Gannon's website. Also stated that citizens may receive other important information on her website as well, such as information about the DeKalb Spring break mini day camp April 3rd-7th at various recreation centers around the County. Mentioned the April 5th CEO Water Billing Town Hall, and also stated that her office will be putting out more information on the Community Gardens Program. Commissioner Gannon recognized Jessica Whimper, the Columbia High School student who spoke so eloquently in the Public Comments section of the meeting. Commissioner Gannon also gave a shout out to Sheriff Jeff Mann for enforcing the DeKalb County constitution by not detaining people in jail without proper warrants and keeping people's rights in mind. Lastly, she thanked everyone for working so hard to speed through the agenda.

POLICY OF NON-DISCRIMINATION ON THE BASIS OF DISABILITY IN COUNTY SERVICES.

DeKalb County Government does not discriminate against qualified individuals with disabilities or exclude them from participating in or receiving benefits of its services, programs, or activities, based on disability. Janet Essix, DeKalb County Government's Employee Relations Manager and ADA Coordinator, is designated to coordinate the County's compliance with Part 35 of the Department of Justice regulations regarding the Americans with Disabilities Act. Janet Essix may be contacted at 1300 Commerce Drive, 1st Floor, Decatur, GA 30030, 404.371.2309, to request information about access for persons with disabilities to County services, programs and activities, or to discuss a grievance regarding an impediment to such access. Ten days' notice is requested for special accommodations.

DEKALB COUNTY

ITEM NO. D1

BOARD OF COMMISSIONERS
BUSINESS AGENDA / MINUTES
MEETING DATE: March 28, 2017

HEARING TYPE
Public Hearing

ACTION TYPE
Resolution

SUBJECT: 2017 Budget - Amendment 1 - Public Safety

DEPARTMENT: Chief Executive Officer

PUBLIC HEARING: YES NO

ATTACHMENT: YES NO

PAGES: 1

INFORMATION CONTACT: CEO Michael Thurmond
PHONE NUMBER: (404) 371-2881

Deferred 2/28/17

PURPOSE:

To adopt the 2017 Operating Budget.

NEED/IMPACT:

Per Section 17 of the County's Organizational Act, the CEO is required to submit a proposed budget for the following calendar year. The Organization Act requires a budget be approved and adopted before March 1st by the Board of Commissioners.

- This agenda requests passing of the attached documents:
- Attachment A 2017 Operating Budget Resolution
 - Attachment B Capital Improvement Plan
 - Attachment C Authorized Position Change Schedule
 - Attachment D Vehicle Replacement Schedule
 - Attachment E 2017 Budget Policies and Intent

RECOMMENDATION(S):

To defer until the second Board of Commissioners' meeting in February for passage.

FOR USE BY COMMISSION OFFICE/CLERK ONLY

ACTION : 2017-03-28 ItemD1

MOTION was made by Mereda Davis Johnson, seconded by Jeff Rader and passed 7-0-0-0 to defer for 30 days until April 25, 2017, to adopt the 2017 Operating Budget Amendment 1 - Public Safety.

ADOPTED: MAR 28 2017
(DATE)

Kathie Gannon
PRESIDING OFFICER
DEKALB COUNTY BOARD OF
COMMISSIONERS

CERTIFIED: MAR 28 2017
(DATE)

Barbara A. Grier
CLERK,
DEKALB COUNTY BOARD
OF COMMISSIONERS

FOR USE BY CHIEF EXECUTIVE OFFICER ONLY

APPROVED: APR 05 2017
(DATE)

CHIEF EXECUTIVE OFFICER
DEKALB COUNTY
[Signature]

VETOED: _____
(DATE)

CHIEF EXECUTIVE OFFICER
DEKALB COUNTY

VETO STATEMENT ATTACHED: _____

MINUTES:

Faye Coffield, 3261 Chaparral Way, Lithonia, Ga. 30038, Joe Arrington, 466 S. Rays Road, Stone Mountain, Ga. 30083, Jeff Wiggs, 1238 Ridge Ave, Stone Mountain, Ga. 30083, James McCorkle, 4225 Snapfinger Woods Drive, Decatur, Ga. 30035, spoke in support.

No opposition.

FOR : Kathie Gannon, Steve Bradshaw, Gregory Adams, Nancy Jester, Larry Johnson, Mereda Davis Johnson, Jeff Rader

AGAINST : None

ABSTAIN : None

ABSENT : None

Amendment 1 - Public Safety

In concurrence with the Board of Commissioners, this budget acknowledges public safety as a Budget priority.

The administration and the Board will demonstrate this priority by implementing a mechanism For a comprehensive phased plan of improvements to police salary and benefits, recruitment And retention, and morale, and a review of millage rate and E911 fees to support those efforts. These efforts will be incorporated into the mid-year budget process.

- 1. 10% MID YEAR WITH HAZARD PAY AND NIGHT DIFFERENTIAL. ?

2. 10% INCREASE FOR	2017	\$4, 575.261.00	(4 Months)
	2018	\$16,242,176.00	Annualized
	2019	\$23,917,176.00	Annualized
	2020	\$29,201,602.00	Annualized

DEPARTMENTS:

- 1. POLICE
- 2. SHERIFF
- 3. FIRE
- 4. MARSHALLS
- 5. POST CERTIFIED PROBATION OFFICERS

- 1. What is the mill rate increase for this proposal: 2.25%
- 2. Average household increase per year is about \$100
- 3. Total cost is \$29,201,602

ITEM NO. D2

BOARD OF COMMISSIONERS

BUSINESS AGENDA / MINUTES

MEETING DATE: March 28, 2017

HEARING TYPE
Public Hearing

ACTION TYPE
Resolution

SUBJECT: 2017 Budget - Amendment 6 - Removal of Budget Policies Until a Later Date

DEPARTMENT: Chief Executive Officer

PUBLIC HEARING: YES NO

ATTACHMENT: YES NO
PAGES: 1

INFORMATION CONTACT: CEO Michael Thurmond
PHONE NUMBER: (404) 371-2881

Deferred 2/28/17

PURPOSE:

To adopt the 2017 Operating Budget.

NEED/IMPACT:

Per Section 17 of the County's Organizational Act, the CEO is required to submit a proposed budget for the following calendar year. The Organization Act requires a budget be approved and adopted before March 1st by the Board of Commissioners.

- This agenda requests passing of the attached documents:
- Attachment A 2017 Operating Budget Resolution
 - Attachment B Capital Improvement Plan
 - Attachment C Authorized Position Change Schedule
 - Attachment D Vehicle Replacement Schedule
 - Attachment E 2017 Budget Policies and Intent



RECOMMENDATION(S):

To defer until the second Board of Commissioners' meeting in February for passage.

FOR USE BY COMMISSION OFFICE/CLERK ONLY

ACTION : 2017-03-28 ItemD2

MOTION was made by Nancy Jester, seconded by Jeff Rader and passed 7-0-0-0 to **withdraw** the 2017 Budget Amendment 6 - Removal of Budget Policies.

ADOPTED: MAR 28 2017
(DATE)

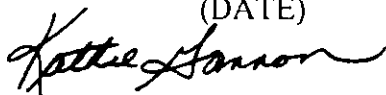

PRESIDING OFFICER
DEKALB COUNTY BOARD OF
COMMISSIONERS

CERTIFIED: MAR 28 2017
(DATE)

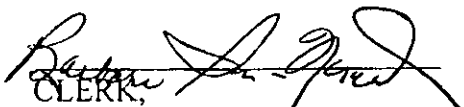

CLERK,
DEKALB COUNTY BOARD
OF COMMISSIONERS

FOR USE BY CHIEF EXECUTIVE OFFICER ONLY

APPROVED: APR 05 2017
(DATE)

CHIEF EXECUTIVE OFFICER
DEKALB COUNTY

VETOED: _____
(DATE)

CHIEF EXECUTIVE OFFICER
DEKALB COUNTY

VETO STATEMENT ATTACHED: _____

MINUTES:

FOR : Kathie Gannon, Steve Bradshaw, Gregory Adams, Nancy Jester, Larry Johnson, Mereda Davis Johnson, Jeff Rader

AGAINST : None

ABSTAIN : None

ABSENT : None

Amendment 6 - Removal of Budget Policies Until a Later Date

Schedule E Budget Policies and Intentions are removed from this item to be revised and submitted at a later date.

DEKALB COUNTY

ITEM NO. D3

BOARD OF COMMISSIONERS
BUSINESS AGENDA / MINUTES
MEETING DATE: March 28, 2017

HEARING TYPE
Public Hearing

ACTION TYPE
Resolution

SUBJECT: Street Light Petition- Reevey Lane

DEPARTMENT: Public Works – Transportation

PUBLIC HEARING: YES NO

ATTACHMENT: YES No

PAGES: 2

INFORMATION CONTACT: David Pelton
5195 S. 2nd St.
(770) 492-5206
PHONE NUMBER: ~~5195 S. 2nd St.~~

PURPOSE:

To consider adopting the attached resolution creating Street Light District 117C in Land Lot 228 of the 18th District for the following street: Reevey Lane; and
To consider authorizing the Chief Executive Officer to execute all necessary documents pertaining to this project.

NEED/IMPACT:

Owners of 100% of the total front footage have signed the petition. The public hearing has been advertised and appropriate signs have been posted in the area notifying the residents.

FISCAL IMPACT:

The developer has paid Georgia Power \$3,745.52 for the installation costs. All abutting property owners on this street will be assessed seventy-four cents (\$0.74) per lighted foot per year in accordance with County Policy. There will be no direct cost to DeKalb County.

RECOMMENDATION:

Adopt the attached resolution to create Street Light District 117C in Land Lot 228 of the 18th District and have the street lights installed on Reevey Lane; and
Authorize the Chief Executive Officer to execute all necessary documents pertaining to this project.

FOR USE BY COMMISSION OFFICE/CLERK ONLY

ACTION : 2017-03-28 ItemD3

MOTION was made by Nancy Jester, seconded by Gregory Adams and passed 7-0-0-0 to approve the attached resolution to create Street Light District 117C in Land Lot 228 of the 18th District and have the street lights installed on Reevely Lane; and Authorize the Chief Executive Officer to execute all necessary documents pertaining to this project.

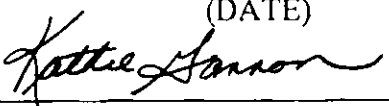
ADOPTED: MAR 28 2017
(DATE)

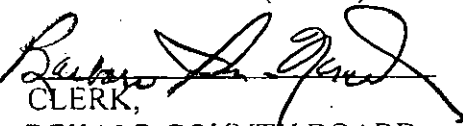
PRESIDING OFFICER
DEKALB COUNTY BOARD OF
COMMISSIONERS

CERTIFIED: MAR 28 2017
(DATE)

CLERK,
DEKALB COUNTY BOARD
OF COMMISSIONERS

FOR USE BY CHIEF EXECUTIVE OFFICER ONLY

APPROVED: APR 05 2017
(DATE)

CHIEF EXECUTIVE OFFICER
DEKALB COUNTY

VETOED: _____
(DATE)
CHIEF EXECUTIVE OFFICER
DEKALB COUNTY

VETO STATEMENT ATTACHED: _____

MINUTES:

FOR : Kathie Gannon, Steve Bradshaw, Gregory Adams, Nancy Jester, Larry Johnson, Mereda Davis Johnson, Jeff Rader

AGAINST : None

ABSTAIN : None

ABSENT : None

REV. 10/06

DEKALB COUNTY

ITEM NO.	D4
----------	----

BOARD OF COMMISSIONERS

BUSINESS AGENDA / MINUTES

MEETING DATE: March 28, 2017

HEARING TYPE Public Hearing

ACTION TYPE Resolution

SUBJECT: Traffic Calming Petition- Cocklebur (Between Columbia Parkway and Cocklebur Rd)
Commission Districts: 3 & 7

DEPARTMENT	Public Works - Transportation
------------	-------------------------------

PUBLIC HEARING:	<input checked="" type="checkbox"/> YES	<input type="checkbox"/> NO
-----------------	---	-----------------------------

ATTACHMENT:	<input checked="" type="checkbox"/> YES <input type="checkbox"/> No
PAGES:	2

INFORMATION CONTACT:	David Pelton
PHONE NUMBER:	(770) 492-5206

PURPOSE:

To consider adopting the attached resolution creating Traffic Calming District 17-15-03 in Land Lots 92, 93 & 101 of the 15th District, to consider authorizing the installation of traffic calming measures (speed tables) and appropriate signage on Cocklebur Trail (Between Columbia Parkway and Cocklebur Rd.) and to consider assessing all properties in the affected area an annual maintenance cost of \$25.00.

NEED/IMPACT:

Speeding has been confirmed on Cocklebur Trail (Between Columbia Parkway and Cocklebur Rd.), which meets the criteria for traffic calming measures. Owners of 68.75% of the eligible properties in the identified affected area have signed the petition to have traffic calming measures installed. The public hearing has been advertised and appropriate signs have been posted notifying residents in the area.

FISCAL IMPACT:

The cost of initial installation of traffic calming measures is included in the Roads & Drainage Budget. All properties in the affected area will be assessed a yearly maintenance cost of \$25.00 during the life of the traffic calming measures beginning the first year after installation.

RECOMMENDATION:

Adopt the attached resolution to create Traffic Calming District 17-15-03 in Land Lots 92, 93 & 101 of the 15th District; and Authorize the installation of traffic calming measures (speed tables) and appropriate signage on Cocklebur Trail (Between Columbia Parkway and Cocklebur Rd.) in the district; and assess all properties in the affected area of the district an annual \$25.00 maintenance cost after the first year through the life of the traffic calming measures.

FOR USE BY COMMISSION OFFICE/CLERK ONLY

ACTION : 2017-03-28 ItemD4

MOTION was made by Larry Johnson, seconded by Gregory Adams and passed 7-0-0 to approve the attached resolution to create Traffic Calming District 17-15-03 in Land Lots 92, 93 & 101 of the 15th District; and Authorize the installation of traffic calming measures (speed tables) and appropriate signage on Cocklebur Trail (Between Columbia Parkway and Cocklebur Rd.) in the district; and assess all properties in the affected area of the district an annual \$25.00 maintenance cost after the first year through the life of the traffic calming measures.

ADOPTED: MAR 28 2017
(DATE)

PRESIDING OFFICER
DEKALB COUNTY BOARD OF
COMMISSIONERS

CERTIFIED: MAR 28 2017
(DATE)

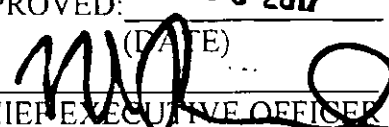
CLERK,
DEKALB COUNTY BOARD
OF COMMISSIONERS

FOR USE BY CHIEF EXECUTIVE OFFICER ONLY

APPROVED: APR 05 2017
(DATE)

CHIEF EXECUTIVE OFFICER
DEKALB COUNTY

VETOED: _____
(DATE)
CHIEF EXECUTIVE OFFICER
DEKALB COUNTY

VETO STATEMENT ATTACHED: _____

MINUTES:

FOR : Kathie Gannon, Steve Bradshaw, Gregory Adams, Nancy Jester, Larry Johnson, Mereda Davis Johnson, Jeff Rader

AGAINST : None

ABSTAIN : None

ABSENT : None

DEKALB COUNTY

ITEM NO. D5

BOARD OF COMMISSIONERS

BUSINESS AGENDA / MINUTES

MEETING DATE: March 28, 2017

HEARING TYPE
Public Hearing

ACTION TYPE
Resolution

SUBJECT: Street Light Petition- Haynes Park Drive, Garden Glade Lane, Haynes Park Place, and Haynes Park Circle

DEPARTMENT: Public Works - Transportation

PUBLIC HEARING: YES NO

ATTACHMENT: YES No

PAGES: 2

INFORMATION CONTACT: David Pelton
SUS & M EAM
(770) 492-5206
PHONE NUMBER:

PURPOSE:

To consider adopting the attached resolution creating Street Light District 108B in Land Lot 203 of the 16th District for the following streets: Haynes Park Drive, Garden Glade Lane, Haynes Park Place, and Haynes Park Circle; and

To consider authorizing the Chief Executive Officer to execute all necessary documents pertaining to the project.

NEED/IMPACT:

Owners of 100% of the total front footage have signed the petition. The public hearing has been advertised and appropriate signs have been posted in the area notifying the residents.

FISCAL IMPACT:

The developer has paid Georgia Power \$ 3,745.52 in installation costs. All abutting property on this street will be assessed seventy-two cents (\$0.72) per lighted foot per year in accordance with County Policy.

RECOMMENDATION:

Adopt the attached resolution creating Street Light District 108B in Land Lot 203 of the 16th District for the following streets: Haynes Park Drive, Garden Glade Lane, Haynes Park Place, and Haynes Park Circle; and

Authorize the Chief Executive Officer to execute all necessary documents pertaining to the project.

FOR USE BY COMMISSION OFFICE/CLERK ONLY

ACTION : 2017-03-28 ItemD5

MOTION was made by Mereda Davis Johnson, seconded by Steve Bradshaw and passed 7-0-0-0 to approve the attached resolution creating Street Light District 108B in Land Lot 203 of the 16th District for the following streets: Haynes Park Drive, Garden Glade Lane, Haynes Park Place, and Haynes Park Circle; and Authorize the Chief Executive Officer to execute all necessary documents pertaining to the project.

ADOPTED: MAR 28 2017
(DATE)

Kathie Gannon
PRESIDING OFFICER
DEKALB COUNTY BOARD OF
COMMISSIONERS

CERTIFIED: MAR 28 2017
(DATE)

Barbara A. Grier
CLERK,
DEKALB COUNTY BOARD
OF COMMISSIONERS

FOR USE BY CHIEF EXECUTIVE OFFICER ONLY

APPROVED: APR 05 2017
(DATE)

[Signature]
CHIEF EXECUTIVE OFFICER
DEKALB COUNTY

VETOED: _____
(DATE)

CHIEF EXECUTIVE OFFICER
DEKALB COUNTY

VETO STATEMENT ATTACHED: _____

MINUTES:

FOR : Kathie Gannon, Steve Bradshaw, Gregory Adams, Nancy Jester, Larry Johnson, Mereda Davis Johnson, Jeff Rader

AGAINST : None

ABSTAIN : None

ABSENT : None

STREET LIGHT RESOLUTION

A resolution providing for the installation of street lights and the assessment of the annual cost of maintaining and operating said lights against abutting property.

WHEREAS, Article IX, Section V, Paragraph 1, of the Constitution of the State of Georgia of 1976, as amended in 1983 (Ga. Laws 1983, Vol. 2, Page 724) authorizes and empowers the Board of Commissioners of DeKalb County, Georgia to establish districts for the purpose of building, erecting, establishing, maintaining, and operating street lights for the illumination of the public streets, roads, and sidewalks in DeKalb County, and to levy a special assessment or tax against all property served by these functions; and

WHEREAS, the owners of fifty-one (51) percent or more of the property affected by the hereinafter described improvements have petitioned the Board of Commissioners of DeKalb County, Georgia, for the installation of street lights.

NOW, THEREFORE, BE IT RESOLVED, by the Board of Commissioners, DeKalb County, Georgia, as the governing body of said County, that there be and there is hereby created and established within the area of DeKalb County, Street Light District Number **108B**, for the purpose of building, erecting, establishing, maintaining, and operating street lights and lamps for the illumination of the public streets, roads, sidewalks, and ways therein, located in Land Lots **203** of the **16th** District of DeKalb County, Georgia, consisting of all or portions of the following streets: **Haynes Park Drive, Garden Glade Lane, Haynes Park Place, and Haynes Park Circle** as more particularly shown and delineated on map entitled "Street Light District Number **108B**" which map is attached hereto and made a part of this resolution by reference; and

BE IT FURTHER RESOLVED the boundaries of said district as enumerated on said map be the same and hereby established as shown and delineated on said map as full and complete as if the full legal description of the courses, distances, and boundaries of said district were fully set forth herein.

BE IT FURTHER RESOLVED the annual cost and charges for the maintenance and operation of said street lights shall not exceed **\$0.72** per foot per year and shall be a lien upon the abutting property annually from January 1st next and continuing each year until all annual charges have been paid provided, however, that said annual charges may be increased by the Board of Commissioners to reflect increases in operating and maintenance costs.

IT IS ORDERED that a copy of this resolution be transmitted to the Tax Commissioner of DeKalb County, Georgia for the collection of any and all taxes and/or special assessments and/or service charges which may be imposed against any and all businesses, residents, and property served by said facilities.

ADOPTED BY the Board of Commissioners of DeKalb County, Georgia this 28th day of March, 2017.

 KATHIE GANNON
 Presiding Officer
 Board of Commissioners
 DeKalb County, Georgia

APPROVED BY the Chief Executive Officer of DeKalb County, Georgia this 28th day of March, 2017.

ATTEST:

 BARBARA H. SANDERS-NORWOOD, CCC
 Clerk to the Board of Commissioners
 and Chief Executive Officer
 DeKalb County, Georgia

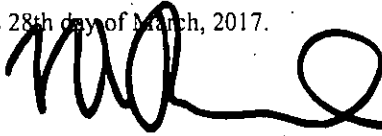

 MICHAEL L. THURMOND
 Chief Executive Officer
 DeKalb County, Georgia

STREET LIGHTS DISTRICT 108B

LAND LOT: 203 16TH DISTRICT
COMMISSION DISTRICTS #5 & #7

HAYNES PARK

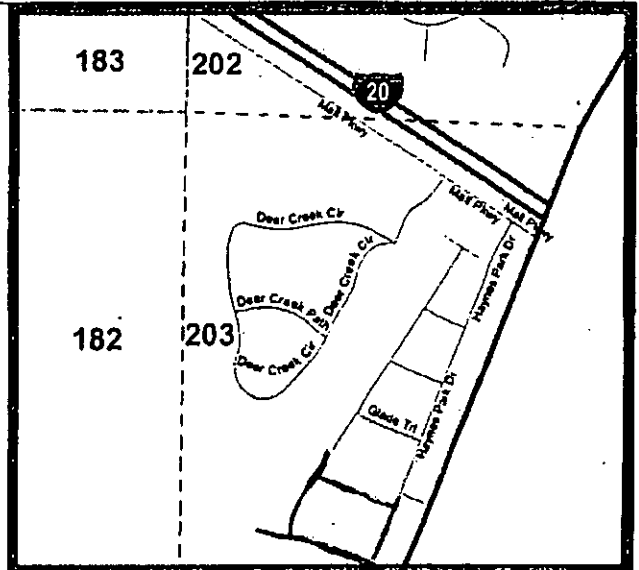
OWNERS WHO SIGNED PETITION



LOCATION MAP

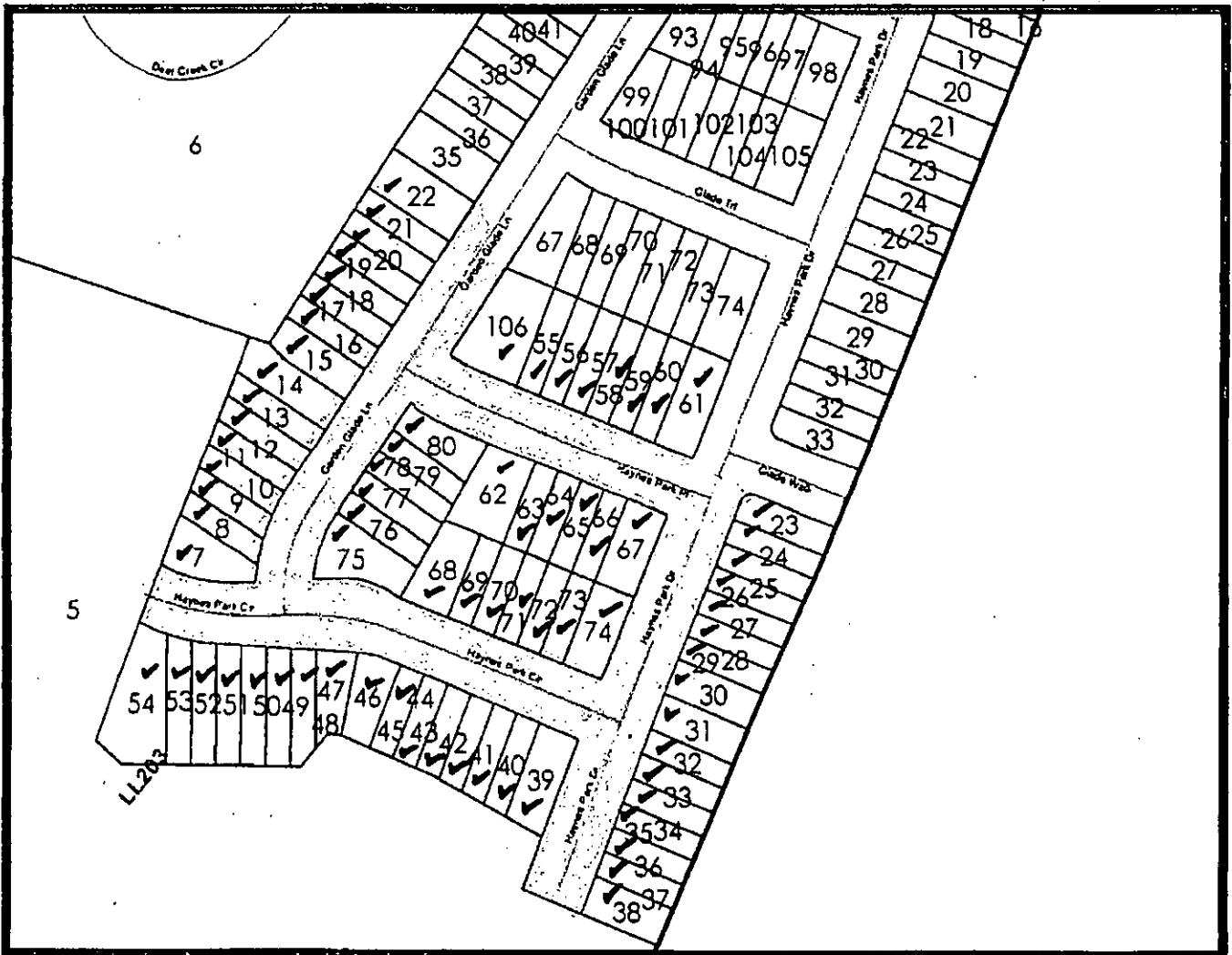

DEKALB COUNTY

ITEM NO. F1

BOARD OF COMMISSIONERS

BUSINESS AGENDA / MINUTES

MEETING DATE: March 28, 2017

HEARING TYPE
Appointment

ACTION TYPE
Resolution

SUBJECT: Appointment to the DeKalb County Department of Family and Children Services Board - Ms. Jane Wilkov, MD

DEPARTMENT: CEO

PUBLIC HEARING: YES NO

ATTACHMENT: YES No
PAGES: 3

INFORMATION CONTACT: Lee May
Interim Chief Executive Officer
PHONE NUMBER: 404-371-2881

Deferred 11/15/16, 1/10/17; 2/14/17, 3/14/17

PURPOSE:

Pursuant to 13A of the Organizational Act where "The chief executive shall nominate a person by sending a written notice to the commission," Interim CEO May is nominating Ms. Jane Wilkov, MD for appointment to the DeKalb County Department of Family and Children Services Board. This term will begin immediately and will expire on November 31, 2021.

NEED/IMPACT:

The DeKalb County Department of Family and Children Services Board (DFCS) assists and supports families to ensure children are safe from abuse, and families can become more self-sufficient. Georgia code 49-3-2(a) indicates that the County governing authority shall appoint members to the DFCS Board. Ms. Jane Wilkov, MD has been properly vetted by the DeKalb County Department of Family and Children Services Board and the Administration. She is a practicing pediatrician and administrator at DeKalb Pediatric Center and would be an asset to the county and those who rely on the services provided through the DeKalb County Department of Family and Children Services.

RECOMMENDATION:

To confirm the appointment of Ms. Jane Wilkov, MD to the DeKalb County Department of Family and Children Services Board.

FOR USE BY COMMISSION OFFICE/CLERK ONLY

ACTION : 2017-03-28 ItemF1

MOTION was made by Jeff Rader, seconded by Nancy Jester and passed 7-0-0-0 to approve the appointment of Ms. Jane Wilkov, MD to the DeKalb County Department of Family and Children Services Board.

Items F1 and F2 were heard together.

ADOPTED: MAR 28 2017
(DATE)

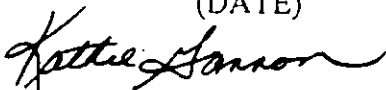

PRESIDING OFFICER
DEKALB COUNTY BOARD OF
COMMISSIONERS

CERTIFIED: MAR 28 2017
(DATE)



CLERK,
DEKALB COUNTY BOARD
OF COMMISSIONERS

FOR USE BY CHIEF EXECUTIVE OFFICER ONLY

APPROVED: APR 05 2017
(DATE)

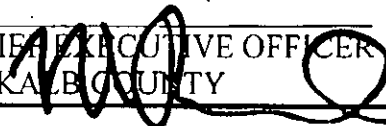

CHIEF EXECUTIVE OFFICER
DEKALB COUNTY

VETOED: _____
(DATE)

CHIEF EXECUTIVE OFFICER
DEKALB COUNTY

VETO STATEMENT ATTACHED: _____

MINUTES:

FOR : Kathie Gannon, Steve Bradshaw, Gregory Adams, Nancy Jester, Larry Johnson, Mereda Davis Johnson, Jeff Rader

AGAINST : None

ABSTAIN : None

ABSENT : None

DEKALB PEDIATRIC CENTER

F1



Jane Wilkov, MD, Debby Pollack, MD, Michal Loventhal, MD,
Melinda Shelton, MD, Rebecca Kolesky, MD, Peggy Marcus, MD,
Ashley Bufe, MD, Laura Babcock, DO,
Andrew Godfrey-Kittle, MD & Lesley Cogburn, RN, CPNP

March 17, 2016

To Whom it May Concern,

I am honored to be recommended as a candidate to serve on the DeKalb County Department of Family & Children Services (DFCS) Advisory Board. As a practicing pediatrician and administrator of a diverse private practice in Dekalb County, I have interacted in many ways with Dekalb County DFACS over the past 30 years.

Early in my career, before other specialized services were available in the county, I did interviews and exams on children in whom sexual abuse was suspected, working closely with DFACS, the police, and judicial system. Our practice currently cares for many children in the foster care system, including many with special needs. We also, unfortunately, have had to refer more than a few of our patients to DFACS, coordinating care and follow up with case managers.

I have spent years growing a private practice that serves children and families in Dekalb County from all socio-economic, educational and cultural backgrounds. Serving on the Board would be an opportunity to help support the work DFACS does and to bring a perspective from the private sector, looking for ways to fund and continue to improve the services DFACS provides to all children in the county.

Thank you for the opportunity. Please contact me with any questions.

Sincerely,

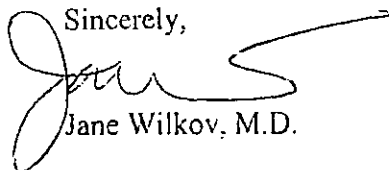

Jane Wilkov, M.D.

CURRICULUM VITAE

Name: Jane L. Wilkov, M.D.
Business Address: DeKalb Pediatric Center, P.C.
350 Winn Way
Decatur, Georgia 30030
Business Phone: (404) 508-1177
Email: Janewmd@dekalbpeds.net
Date of Birth: November 14, 1956
Place of Birth: New York, New York
Marital Status: Married
Spouse: Bruce L. Winston, C.P.A.
Children: Andrew David, Allison Sarah, and Jonathan Phillip

Education

Undergraduate:	Emory University Atlanta, Georgia Bachelor of Arts in Psychology	June 1978
Graduate:	Emory University School of Medicine Atlanta, Georgia Doctor of Medicine	June 1982
Post Graduate:	Emory University Affiliated Hospitals Pediatric Residency	July 1982-June 1985
	Emory University Affiliated Hospitals Chief Resident	July 1985-June 1986
Licensure:	Georgia Certificate 27689	July 1985
Certification:	American Board of Pediatrics	February 1987

Professional

Organizations:	American Academy of Pediatrics, Fellow	1987-Present
	Subsection on Practice Management	2014- Present

Hospital Affiliations:	DeKalb Medical Center 2701 N. Decatur Rd. Decatur, GA 30030	Active	July 1986-Present
	Children's Healthcare of Atlanta Egleston 1405 Clifton Rd. Atlanta, GA 30322	Active	July 1986-Present
	Piedmont Hospital 1968 Peachtree Rd. Atlanta, GA 30305	Active	July 1986-Present
Work History:	DeKalb Pediatric Center, P.C. Decatur, Georgia		September 1992 - Present
	Snapfinger Woods Pediatrics		July 1986 - August 1992
Special Interest:	Childhood Obesity Practice Management		
Appointments:	Chairman Committee on Child Abuse and Neglect, Georgia Chapter American Academy of Pediatrics		January 1993 - December 1996
	Georgia Academy for Children and Youth Professionals, Training Reviewer		June 1993
	Chairman Department of Pediatrics DeKalb Medical Center		October 1994-October 1998
	Health Check Advisory Committee Department Medical Assistance		October 1995-June 1998
	DMA Physician's Advisory Committee		September 1998-2004
	Provider Association Medicaid Task Force		July 2002- 2005, 2007-2009
	Kid Health First Board		2004-2006
	Kids Health First Malpractice Board		2010 - Present
	The Children's Care Network, Contracting Committee		2014-present

DEKALB COUNTY

ITEM NO. F2

BOARD OF COMMISSIONERS
BUSINESS AGENDA / MINUTES
MEETING DATE: March 28, 2017

HEARING TYPE
Appointment

ACTION TYPE
Resolution

SUBJECT: Appointment to the DeKalb County Department of Family and Children Services Board - Pastor Christopher Case

DEPARTMENT: CEO

PUBLIC HEARING: YES NO

ATTACHMENT: YES No
PAGES: 2

INFORMATION CONTACT: Lee May
Interim Chief Executive Officer
PHONE NUMBER: 404-371-2881

Deferred 11/15/16, 1/10/17, 2/14/17, 3/14/17

PURPOSE:

Pursuant to 13A of the Organizational Act where "The chief executive shall nominate a person by sending a written notice to the commission," Interim CEO May is nominating Pastor Christopher Case for appointment to the DeKalb County Department of Family and Children Services Board. This term will begin immediately and will expire on November 31, 2021.

NEED/IMPACT:

The DeKalb County Department of Family and Children Services Board (DFCS) assists and supports families to ensure children are safe from abuse, and families can become more self-sufficient. Georgia code 49-3-2(a) indicates that the County governing authority shall appoint members to the DFCS Board. Pastor Christopher Case has been properly vetted by the DeKalb County Department of Family and Children Services Board and the Administration. He is the lead Pastor at Resonate Church and would be an asset to the county and those who rely on the services provided through the DeKalb County Department of Family and Children Services.

RECOMMENDATION:

To confirm the appointment of Pastor Christopher Case to the DeKalb County Department of Family and Children Services Board.

FOR USE BY COMMISSION OFFICE/CLERK ONLY

ACTION : 2017-03-28 ItemF2.

MOTION was made by Jeff Rader, seconded by Nancy Jester and passed 7-0-0-0 to approve the appointment of Pastor Christopher Case to the DeKalb County Department of Family and Children Services Board.

Items F1 and F2 were heard together.

ADOPTED: MAR 28 2017
(DATE)



PRESIDING OFFICER
DEKALB COUNTY BOARD OF
COMMISSIONERS

CERTIFIED: MAR 28 2017
(DATE)

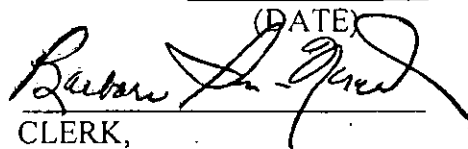

CLERK,
DEKALB COUNTY BOARD
OF COMMISSIONERS

FOR USE BY CHIEF EXECUTIVE OFFICER ONLY

APPROVED: APR 05 2017
(DATE)

CHIEF EXECUTIVE OFFICER
DEKALB COUNTY

VETOED: _____
(DATE)

CHIEF EXECUTIVE OFFICER
DEKALB COUNTY

VETO STATEMENT ATTACHED: _____

MINUTES:

FOR : Kathie Gannon, Steve Bradshaw, Gregory Adams, Nancy Jester, Larry Johnson, Mereda Davis Johnson, Jeff Rader

AGAINST : None

ABSTAIN : None

ABSENT : None

RESONATE
CHURCH

533 W Howard Ave, Ste D
Decatur, GA 30030
678-607-6076
www.resonateatlanta.org

To Whom It May Concern:

I am writing to express my interest in the Advisory Board of the Department of Family and Children Services in Dekalb County. I would like to be considered by the Dekalb Commissioners for this role.

Sincerely,

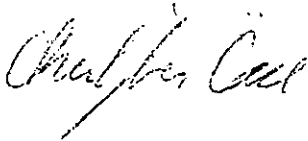

Christopher Case
Lead Pastor, Resonate Church
www.resonateatlanta.org



CHRIS CASE

28 Rogers St NE
Atlanta, GA 30317

404 386 9608

chriscase@resonateatlanta.org
resonateatlanta.org

SUMMARY

An effective leader and communicator, skilled in enlisting the support of all team members in aligning with organizational goals and inspiring and developing young leaders.

EXPERIENCE

Lead Pastor, Resonate Church

Decatur, GA— 2012-2016

Founding pastor of Resonate Church, a 3 ½ year old church plant that has gone from 10 to 200 members in its short time. We meet weekly for worship, have groups throughout the week, and serve the community, particularly the Refugee community in Clarkston and the foster system in Dekalb.

Accomplishments

- Grew the church from 10 to 200 in 3 years
- Have started and launched close to 60 discipleship groups, including raising leaders and ongoing training.
- Have mobilized large teams of people to volunteer around the city including a 1000 person neighborhood festival, a renovation of DFCS offices, and a supply drive for refugee families.

Worship Pastor, Cumberland Community Church

City, State — 1989-1990

Oversaw the music and arts programs at the church, as well as the Sunday worship services.

Accomplishments

- Created multiple band rotations for our Sunday worship.
- Instituted a development program for middle and high schoolers to train them for worship leadership
- Create production and stage design teams.

EDUCATION

Reformed Theological Seminary

Masters of Arts in Religion— 2002-2006

SKILLS

- Leadership development
- Teaching and training.
- Organizational strategy and vision.

REFERENCES

Available upon request.

March 10, 2017

REV 10/02

DEKALB COUNTY

ITEM NO.	F3
----------	----

BOARD OF COMMISSIONERS

HEARING TYPE Appointment

BUSINESS AGENDA / MINUTES

MEETING DATE: 3/28/2017

ACTION TYPE Resolution

SUBSTITUTE

SUBJECT: To Approve the Appointment of Two Recommended Nominees to the Doraville Tax Allocation District (TAD) Advisory Committee.

DEPARTMENT: Economic Development

PUBLIC HEARING:	<input type="checkbox"/> YES	<input checked="" type="checkbox"/> NO
-----------------	------------------------------	--

ATTACHMENT:	<input checked="" type="checkbox"/> YES <input type="checkbox"/> No
PAGES:	5

INFORMATION CONTACT:	Luz Borrero Deputy COO of Development
PHONE NUMBER:	(404) 371-2562

PURPOSE:

On February 6, 2017 the Board of Commissioners approved an Amended and Restated Intergovernmental Agreement with the City of Doraville to allow for the establishment of a Tax Allocation District (TAD). The City and the County agreed to create a TAD Advisory Committee to consider TAD matters, including requests for TAD financing for projects and other matters. The legislation established that the TAD Advisory Committee will be composed of five members which shall consist of two members appointed by the City Council of the City, two members appointed by the County Governing Authority and one member appointed by the four remaining members of the Advisory Committee.

NEED/IMPACT:

The establishment of the TAD Advisory Committee is necessary for the City to exercise its ability to authorize the issuance of TAD bonds or other authorized means of TAD financing. The TAD Advisory Committee members shall have substantial expertise in finance and/or Tax Allocation Districts. Michael Thurmond, Chief Executive Officer is hereby nominating the following individuals to represent DeKalb County in the TAD Advisory Committee:

Ms. Linda Chatmon
Xavier Peoples

RECOMMENDATION:

Approve the appointment of recommended nominees to the TAD Advisory Committee. Bios and resumes for each of the nominees are attached.

FOR USE BY COMMISSION OFFICE/CLERK ONLY

ACTION : 2017-03-28 ItemF3

MOTION was made by Jeff Rader, seconded by Steve Bradshaw and passed 7-0-0-0 to approve previous substitute, the appointment of Linda Chatmon to the TAD Advisory Committee.

MOTION was made by Jeff Rader, seconded by Gregory Adams and passed 7-0-0-0 to **withdraw** the appointment of recommended nominee of Kelsi Queen-Robinson to the TAD Advisory Committee.

ADOPTED: MAR 28 2017
(DATE)



PRESIDING OFFICER
DEKALB COUNTY BOARD OF
COMMISSIONERS

CERTIFIED: MAR 28 2017
(DATE)

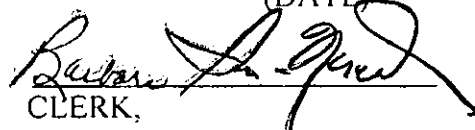

CLERK,
DEKALB COUNTY BOARD
OF COMMISSIONERS

FOR USE BY CHIEF EXECUTIVE OFFICER ONLY

APPROVED: APR 05 2017
(DATE)



CHIEF EXECUTIVE OFFICER
DEKALB COUNTY

VETOED: _____
(DATE)

CHIEF EXECUTIVE OFFICER
DEKALB COUNTY

VETO STATEMENT ATTACHED: _____

MINUTES:

FOR : Kathie Gannon, Steve Bradshaw, Gregory Adams, Nancy Jester, Larry Johnson, Mereda Davis Johnson, Jeff Rader

AGAINST : None

ABSTAIN : None

ABSENT : None

LINDA G. CHATMON

Linda Chatmon is the sole principal of Contracts and Grants, LLC and several other brands, all of which contribute to the growth of small businesses through contracts and grants, technology, and e-learning. A Subject Matter Expert in Federal and Defense Acquisitions, she has 22 years of experience in Federal Acquisition Proposal/Contract Support, Program Management and is also a contractor. Through the direction of Ms. Chatmon, Contracts and Grants has been responsible for more than 2.2 Billion dollars in contracts and grant negotiations and awards since 2011, of which 356 Million was awarded. This was accomplished with various clients with various agencies, in various countries, in the areas of Information Technology, Construction, Telecommunications, Facilities Maintenance, Facilities Management, Logistics, Operation and Maintenance and Base Support as well as a variety of and numerous GSA Schedules and 8a certifications. Contracts and Grants operate globally, and have been particularly successful in SW Asia.

As an entrepreneur with a diversified portfolio, Ms. Chatmon owns The App Diva, LLC, a technology firm that specializes in application development, with a focus on the needs of entrepreneurs, small businesses, entertainers, travelers and celebrities. Working with hundreds of firms over the span of her career, Ms. Chatmon recognized that there were common denominators of small business owners and created a suite of apps to accommodate those unique and diverse needs. Other brands include: Person Behind The Brand, a web series dedicated to showcasing who we are behind our brands; PARS (Performance Assessment Rating System) a web based tool that provides small businesses a way to *demonstrate* their ability to be successful contractors, and TEN (Teaming Exchange Network) an algorithm driven technology tool that matches up PARS participants with each other to maximize teaming relationships. She is the author of 2 books titled, *The Road to Government Contracts*, and *Grantworthy*. A third book, based on Ms. Chatmon's personal journey on *The Road to Government Contracts* is slated to be released this summer.

Ms. Chatmon attended the University of North Carolina, and prior to entrepreneurship, was employed as a paralegal and responsible for contract administration and management for a large pharmaceutical corporation headquartered in Osaka Japan. Ms. Chatmon's responsibilities included contract negotiation, contract administration, and protocol compliance for clinical trials.

A native of North Carolina, and resident of Washington DC suburbs for more than 20 years, Ms. Chatmon now resides in McDonough, GA. She has two adult children, Michael an auditor for the State of Georgia, Jocelyn a Case Manager for Homeland Security in Washington DC, and grandson Jason.

LINDA G. CHATMON
1005 Odelle Circle
McDonough, Ga 30253
678-490-1036

Statement of Qualifications: Twenty -two years as the founder and CEO of a consulting firm that specializes in the growth of small business through contracts and grants, technology and E-Learning platforms.

PROFESSIONAL EXPERIENCE

Contracts and Grants, CEO

1995-Present

- **Provided Business Development, RFP Response Management and contract support services for various agencies, companies, and individuals**
 - Proposal Management
 - Proposal Writing
 - Contract Administration/Management
 - Teaming/Joint Venture Negotiations
 - Subcontract Management
 - Mentor Protégée Coordinator
 - Cost Price Analysis/Narratives
 - SBIR's/STTRS
 - Small Business Certifications
 - 8a
 - Hubzone
- **Grant writer for Non-Profit Organizations**
- **Knowledge of Federal and Defense Acquisition Regulations**
- **RFP Response Development for a variety of government contractors, for a variety of industries, for a variety of agencies**
- **Management of individual and collective efforts including global collaborations in virtual environments**

ACHIEVEMENTS

- **Responsible for the management of more than 2.2 Billion Dollars in contract award negotiations of which more than 358 million dollars was awarded since 2011.**
- **Awards in US CENCOMM AOR's (Afghanistan) and other Global Markets**
- **Proposal Manager for one of 20 awardees for 2.8 Billion Dollar Logistics IDIQ**
- **52 GSA Schedule Awards (100%)**
- **32 8a Certifications - (98%)**
- **Certified Quality Control Manager - Army Corps of Engineers**
- **Development of Comprehensive Proposal Management Process**
- **Development of 100 Million Dollar Strategic Plan AND Past Performance in having achieved it**
- **Negotiations with Large Primes (CACI, ITT, Raytheon)**

Executive Director

POWER Associates, Inc. (Providing Opportunities for Welfare Reform) 1995-2000

- Founded Non-Profit Workforce Development/Life Skills Training Company to serve hard to serve employment population
- Successfully completed 501(c)3 Application to IRS (Awarded)
- Managed Corporate Vision and Fiscal Responsibilities including day to day Operations
- Identified, Developed, & Implemented Funding, Marketing, and Contracting Strategies and Opportunities through the development and submission of RFP's
- Developed and submitted unsolicited proposal for Government funding which was subsequently awarded
- Project Manager for the development of training curriculums

Individual Consultant

- Subcontracted with 8a Firm in the area of costing and service delivery for multiple government agencies
- Subcontracted with Non-profit Organizations in the area of corporate development (proposal/grant writing)
- Subcontracted with staffing agency for Leadership Training & Development for staff and corporate clients to include Performance Improvement Plans (PIPS) and Customer Service Training
- Developed and implemented workforce development recruitment program to meet the needs of entry level positions for staffing agency (Atlanta) resulting in 200% increase in positions and staff
- Facilitated Empowerment Workshops for National, State, and Local government agencies
- Motivational Speaker for various non-profit organizations and community based organizations
- Featured Keynote Speaker for United States Department of Labor, United States Department of Commerce, United States Small Business Administration
- Served on various workforce development boards, panels, committees

Otsuka Pharmaceutica, Inc. Legal Administrator

(1993-1997)

- Contract Administration for Clinical Trials
- Response to Interrogatories
- Assistant to General Counsel
- Marketing Administrator (1993-1995);
 - Created Marketing Documents and Coordinated Marketing Activity for Sales Reps
 - Liaison between Company and Fulfillment Houses
 - Liaison between Company and Sales Force

Oncor Communications (Supervisor/Activations (1991-1994); with National Academies Travel as Meetings and Conventions Manager (1987-1990); RMS/Worldwide Travel as Travel Agent (1982-1987).

EDUCATION

**Southern California University for Professional Studies Santa Ana, CA
AA Paralegal Studies, 1997 Completed Contracts I, II and Torts I of Juris Doctorate Program**

University of North Carolina - Chapel Hill, Chapel Hill, NC (1979-1981)

* References available upon request.

EXPERIENCE

U.S. Trust/ Bank of America

Private Client Associate/ Vice President

Atlanta, GA
September 2016 – Present

- Manages a team of 8 individuals who serve a book of 35 million dollars in assets under management.
- Deepens banking and investment relationships with clients with 3 million dollars or more.
- Act as trusted advisor to, and an advocate for, clients and prospects; facilitate integrated recommendations that encompass fiduciary investing, high end credit facilities, and wealth in planning
- Prospect, network and develop new business opportunities
- Effectively build and manage a book of relationships and act as relationship lead accountable for the client's experience

Zurich North America

Regional Finance Manager/ Credit Risk Analyst

Atlanta, GA
March 2013 – Present

- Manage credit risk, market risk and operational risk of over 400 mid size and large companies totaling 4 billion dollars.
- Responsible for analyzing and rating companies based on their income statements, balance sheets, statement of cash flows, key performance indicators, scorecards and P/L statements to determine the overall financial health of companies and their creditworthiness.
- Write thorough analysis of company's financial performance and creditworthiness.
- Mitigate credit risk by negotiating collateral requirements for each deal based on past losses and forecasted losses.
- Participate in sales and marketing meetings by presenting financial presentations to prospected accounts and insurance brokers.
- Work closely with insurance underwriters to make sure that Zurich is in the best position to acquire new business by aggressively setting collateral.
- Manage four Financial Analyst controlling workflow, training, and developing performance plans.

Union Bank of California

Senior Business/ Credit Analyst/Assistant /Vice President

San Francisco, CA
December 2009 – June 2012

- Promoted after a year to Sr. Business/Credit Analyst reporting to Executive Vice President of Credit Risk Reporting
- Reviewed commercial, commercial real estate, agricultural, construction and land development loan files of moderate complexity to determine: the borrower's capacity to pay (e.g. balance sheet and income statement); protection (i.e. amount of collateral); performance (e.g. history of payment, level of past-due, cash flow analysis); and the bank's underwriting and credit administration practices (i.e. terms and structure of loan, conveyances and payment terms)
- Responsible for specific commercial credit portfolio sectors or lines of businesses as 2nd Line of Defense to monitor ongoing and incipient concentration risk and risk of credit loss in the Bank's credit portfolio.
- Supported line of business, Credit Administration and Credit Reserve Methodology Analytics team to estimate loan and lease loss reserves and credit migration for the Allowance for Credit Loss process.
- Prepared graphs and basic trend analysis for both monthly and quarterly reporting including analysis of changes between reporting periods.
- Established independent advisory relationships with Relationship Managers in the lines of business and Commercial Credit Administration to develop credit portfolio exposure strategies, undertake tactical risk management solutions to manage those strategies, and ultimately drive portfolio risk optimization.
- Participated in work streams related to the implementation of Basel II and other regulatory compliance initiatives

Union Bank of California

Senior Financial Analyst/Assistant Vice President

San Francisco, CA
September 2008 – December 2009

- Provide complex information and analysis to ensure that the overall credit portfolio management process is accurate and sound
- Lead and participate in audit projects in one or more areas within the department. Under minimal supervision, perform all audit assignments and tasks in the area(s) of audit responsibility, regardless of variety and complexity
- Work closely with the parent company to ensure results reported are accurate, produced within required deadlines, and managed in a controlled process. Communicate with senior management and the parent company on potential reporting issues and propose solutions and alternatives
- Served as IT liaison working with business units throughout the enterprise to add proper data elements to pertinent reports as reporting requirements changed

Senior Financial Planner and Specialist

September 2005 – May 2007

- Ranked top 5 Salesman out of 75 people in the same position exceeding investment, deposit, and loan goals on a monthly basis. Report to the Senior Vice President
- Serve high net worth customers' total financial service needs resulting in greater market share, wallet share and profitability. Develop the structural framework for administering budgets, business development goals and objectives, staffing models, schedules and performance standards
- Directly administered Personal Trust accounts including, estates, investment management, custodial and guardianship accounts. Serve as a part of the Relationship Management Team working closely with Wealth Strategists, Portfolio Managers and external advisors to define and meet clients' tax, financial, estate planning, and banking goals and objectives

Federal Reserve Bank of Atlanta

Atlanta, GA

Financial Analyst

May 2001 – September 2005

- Provided financial analysis and reports for bank holding companies and their subsidiaries. Edited and analyzed highly complex financial data collected from financial institutions, bank holding companies, and non-bank entities in the 6th District for use in developing economic policy and conducting bank supervision and regulation activities
- Reviewed accruals and reconciliations to the banks general ledger. Maintained cash reserve requirements schedules and aging analysis. Tracked fixed assets, realized and unrealized gains and losses. Ensured proper allocation of items to the general ledger
- Worked closely in facilitating quarterly training workshops for 100 respondents (bank Presidents, CFOs, CPAs) on regulatory reporting, report preparation and analytical support (investigations, summaries, spreadsheets)
- Trained 3 interns on small bank holding company financial reports for holding companies owning, at minimum, 25% of banks with assets less than \$150 million. Reviewed team transmission, edited explanations and worked closely with Director to delegate assignments in order to meet high-priority and pre-established deadlines

EDUCATION

Investment Banking Institute

Atlanta, GA

Intensive financial modeling and valuation training program

October 2012

- Performed company valuations utilizing (i) comparable public company analysis, (ii) precedent transactions analysis and (iii) discounted cash flow (DCF) analysis
- Built fully-integrated financial statements projection model, LBO model, accretion/dilution merger models, including ability to run operational and capital structure sensitivities within models and data tables for sensitivity analysis

University of West Georgia

Carrollton, GA

Bachelor of Science

May 2004

- Business Administration: Finance

ADDITIONAL

Skills: MS Word, Excel, PowerPoint, Access, PeopleSoft, Business Objects, Oracle, Quick Books, Pegasus and SQL

License: Series 6 & 7

Boards: Atlanta Police Foundation (Young Guns), Boys and Girls Club (Fulton County), Sweet Auburn Works, Citizens Trust Bank Advisory Board (2016), Influencer Coalition

DEKALB COUNTY

ITEM NO. F4

BOARD OF COMMISSIONERS

BUSINESS AGENDA / MINUTES

MEETING DATE: March 28, 2017

ACTION TYPE
Resolution

HEARING TYPE
Appointment

SUBJECT: Recording the Re-appointment of Beth Nathan to Serve on the Initiative for a Green DeKalb and the Parks Bond Advisory Committee as the Representative of District 2.

DEPARTMENT: District 2, Board of Commissioners

PUBLIC HEARING: YES NO

ATTACHMENT: YES No

PAGES:

INFORMATION: Commissioner Jeff Rader.
CONTACT: District 2
PHONE NUMBER: 404-371-2863

PURPOSE:

To record the reappointment of Beth Nathan to serve on the Initiative for a Green DeKalb and the Parks Bond Advisory Committee as the Representative of District 2.

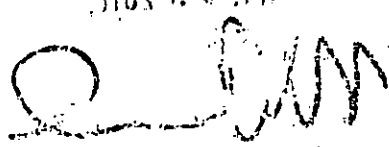
APR 0 2 2017

NEED/IMPACT:

To provide a representative from District 2 to serve on the Initiative for a Green DeKalb and the Parks Bond Advisory Committee.

RECOMMENDATION(S):

Direct the Clerk to record this reappointment of Beth Nathan to serve on the Initiative for a Green DeKalb and the Parks Bond Advisory Committee as the representative of District 2.

FOR USE BY COMMISSION OFFICE/CLERK ONLY

ACTION : 2017-03-28 ItemF4

MOTION was made by Jeff Rader, seconded by Gregory Adams and passed 7-0-0-0 to approve to direct the Clerk to record the reappointment of Beth Nathan to serve on the Initiative for a Green DeKalb and the Parks Bond Advisory Committee as the representative of District 2.

Items F4 thru F7.

ADOPTED: MAR 28 2017
(DATE)
Kathie Gannon
PRESIDING OFFICER
DEKALB COUNTY BOARD OF
COMMISSIONERS

CERTIFIED: MAR 28 2017
(DATE)
Barbara A. Gurd
CLERK,
DEKALB COUNTY BOARD
OF COMMISSIONERS

FOR USE BY CHIEF EXECUTIVE OFFICER ONLY

APPROVED: APR 05 2017
(DATE)
WJ
CHIEF EXECUTIVE OFFICER
DEKALB COUNTY

VETOED: _____
(DATE)
CHIEF EXECUTIVE OFFICER
DEKALB COUNTY

VETO STATEMENT ATTACHED: _____

MINUTES:

FOR : Kathie Gannon, Steve Bradshaw, Gregory Adams, Nancy Jester, Larry Johnson, Mereda Davis Johnson; Jeff Rader

AGAINST : None

ABSTAIN : None

ABSENT : None

REV.

DEKALB COUNTY

ITEM NO: F5

BOARD OF COMMISSIONERS

BUSINESS AGENDA / MINUTES

MEETING DATE: March 28, 2017

HEARING TYPE
Appointment

ACTION TYPE
Resolution

SUBJECT: Recording the Appointment of James Alec Gelin to the Parks Bond Advisory

DEPARTMENT: Board of Commissioners

PUBLIC HEARING: NO

ATTACHMENT: Yes
PAGES: 2

INFORMATION: Steve Bradshaw
CONTACT: District 4 Commissioner
PHONE NUMBER: 404-371-7031

PURPOSE: To record the appointment of James Alec Gelin to the Parks Bond Advisory Committee.

NEED/IMPACT: The Clerk to Chief Executive Officer and the Board of Commissioners would like the minutes of the Commission to reflect appointments made by individual Commissioners to various boards and authorities.

James Alec Gelin has indicated her interest to serve in his capacity as a District 4 appointee. The District 4 Commissioner is prepared to appoint James Alec Gelin to fill the term, to this position with a term ending on December 31, 2020, unless such term ends sooner as provided by law.

RECOMMENDATION(S): Direct the Clerk to record this appointment of James Alec Gelin as a member of Parks Bond Citizen Advisory Committee appointed by the District 4 Commissioner, with a term to begin upon James Alec Gelin being certified/qualified to serve for a term ending on December 31, 2020, unless otherwise provided by applicable law.

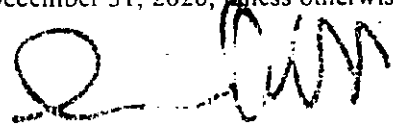



FOR USE BY COMMISSION OFFICE/CLERK ONLY

ACTION : 2017-03-28 ItemF5

MOTION was made by Jeff Rader, seconded by Gregory Adams and passed 7-0-0-0 to approve to direct the Clerk to record the appointment of James Alec Gelin as a member of Parks Bond Citizen Advisory Committee appointed by the District 4 Commissioner, with a term to begin upon James Alec Gelin being certified/qualified to serve for a term ending on December 31, 2020, unless otherwise provided by applicable law.

Items F4 thru F7.

ADOPTED: MAR 28 2017
(DATE)

PRESIDING OFFICER
DEKALB COUNTY BOARD OF
COMMISSIONERS

CERTIFIED: MAR 28 2017
(DATE)

CLERK,
DEKALB COUNTY BOARD
OF COMMISSIONERS

FOR USE BY CHIEF EXECUTIVE OFFICER ONLY

APPROVED: APR 05 2017
(DATE)

CHIEF EXECUTIVE OFFICER
DEKALB COUNTY

VETOED: _____
(DATE)
CHIEF EXECUTIVE OFFICER
DEKALB COUNTY

VETO STATEMENT ATTACHED: _____

MINUTES:

FOR : Kathie Gannon, Steve Bradshaw, Gregory Adams, Nancy Jester, Larry Johnson, Mereda Davis Johnson, Jeff Rader

AGAINST : None

ABSTAIN : None

ABSENT : None

APPLY VISIT REQUEST INFO MY AJMLS

Search...

F5

Search

Primary Menu

FUTURE STUDENTS CURRENT STUDENTS ALUMNI & FRIENDS FACULTY & STAFF

JAMES ALEC GELIN

Associate Professor

jgelin@johnmarshall.edu
678-916-2648



EDUCATION

B.A., Amherst College, *magna cum laude*
J.D., Duke University School of Law, with Honors

COURSES TAUGHT

Criminal Trial Practice, Legal Writing, Research & Analysis I and II; Trial Advocacy & Writing

CAREER HIGHLIGHTS

Professor Gelin is an experienced trial attorney who represented indigent defendants as a Senior Assistant Public Defender with the Office of the DeKalb County Public Defender from 1991 through 2010. Prior to joining the Public Defender's office, he practiced corporate law, first at Goodwin Procter LLP in Boston, and then at Arnall Golden Gregory LLP in Atlanta. Professor Gelin is the Co-Faculty Adviser to the student organization, OutLaw and Allies. From 1994 through 1995, Professor Gelin taught criminal law at Atlanta's John Marshall Law School as an Adjunct Professor.

PUBLICATIONS

Unwarranted Punishment: Why the Practice of Isolating Transgender Youth in Juvenile Detention Facilities Violates the Eighth Amendment, U.C. Davis Journal of Juvenile Law & Policy, Volume 18, Issue 1 (2014).

ATLANTA'S JOHN MARSHALL LAW SCHOOL
1422 W Peachtree St. NW Atlanta, GA 30309
678-916-2600 Fax: 404-873-3802

ABA Disclosures
Admissions
Board of Directors
Privacy Policy

About
Application Process
Faculty
Recruitment Calendar

Accreditation
Apply
LL.M. Programs
Tuition & Expenses



Popular Links

Academic Achievement
Careers
Home for Good

Academic Affairs
Career Development
Library

Academic Calendar
Course Schedules
Technology

AJMLS Merchandise
Character & Fitness

Blackburn Conference Center
Externship Basics on TWEN

Our students come for law school but find a community

James Alec Gelin Addendum to C.V.

In addition to what is mentioned on my C.V., here are some important facts about my career at Atlanta's John Marshall Law School, as well as information about hobbies and some of the community activities that I'm involved in:

1) I pride myself on my accessibility to my students. As many of my students are evening students with full time jobs, they take advantage of my availability during nights and weekends, when I routinely respond to emails and conference with them on the phone.

2) Admissions Committee member since the 2011 – 2012 academic year.

3) Co-Faculty Advisor to OutLaw & Allies, 2013 2014 academic year. The mission of this AJMLS student organization is "to promote scholarly discourse of LGBT issues, social equality issues and tolerance."

4) Member of The Temple, Atlanta's largest Jewish Reform congregation, since 2001. From 2011 – 2013, I served on a committee that explored and then implemented policies and programs meant to make my synagogue a more welcoming place for the LGBTQ community. This committee was part of a pilot project, The Welcoming Synagogues Initiative, that took place simultaneously at approximately twenty-five congregations throughout the United States and Canada. Since 2013, I have been a member of The Temple's Membership Committee.

5) Member of the Planning Committee for "Purim Off Ponce," 2012 and 2013. "Purim Off Ponce" was a benefit for the Rainbow Center, formerly affiliated with Atlanta's Jewish Family & Career Services and now known as SOJOURN. SOJOURN is a Southern regional network providing education, resources and support for LGBTQ teens and their friends and family.

6) Community Activist and tree planter in unincorporated DeKalb County. Since 1998, I have advocated for smart growth and development in my community located north of Avondale Estates. In addition, I have individually planted over two hundred trees throughout the county, mostly at my own expense. Currently, one hundred and seventy-five remain. Of those, I maintain the smaller trees (under ten feet tall,) annually through mulching, weeding and pruning.

7) An avid gardener, I collect and maintain an extensive collection of shrubs and trees on my one acre property.

REV.

DEKALB COUNTY

ITEM NO. F6

BOARD OF COMMISSIONERS
BUSINESS AGENDA / MINUTES
MEETING DATE: March 28, 2017

HEARING TYPE
Appointment

ACTION TYPE
Resolution

SUBJECT: Recording the Appointment of Patrick Medley to the Beautification Committee

DEPARTMENT: Board of Commissioners

PUBLIC HEARING: NO

ATTACHMENT: Yes
PAGES: 4
VOS & S RAM

INFORMATION: Steve Bradshaw
CONTACT: District 4 Commissioner
PHONE NUMBER: 404-371-7031
VOS & S RAM

PURPOSE: To record the appointment of Patrick Medley Beautification Committee.

NEED/IMPACT: The Clerk to Chief Executive Officer and the Board of Commissioners would like the minutes of the Commission to reflect appointments made by individual Commissioners to various boards and authorities.

Patrick Medley has indicated his interest to serve in his capacity as a District 4 appointee. The District 4 Commissioner is prepared to appoint Patrick Medley to fill the term, to this position with a term ending on December 31, 2020, unless such term ends sooner as provided by law.

RECOMMENDATION(S): Direct the Clerk to record this appointment of Patrick Medley as a member of Beautification Committee appointed by the District 4 Commissioner, with a term to begin upon Mr. Medley being certified/qualified to serve for a term ending on December 31, 2020, unless otherwise provided by applicable law.

FOR USE BY COMMISSION OFFICE/CLERK ONLY

ACTION : 2017-03-28 ItemF6

MOTION was made by Jeff Rader, seconded by Gregory Adams and passed 7-0-0-0 to approve to direct the Clerk to record the appointment of Patrick Medley as a member of the Beautification Committee appointed by the District 4 Commissioner, with a term to begin upon Mr. Medley being certified/qualified to serve for a term ending on December 31, 2020, unless otherwise provided by applicable law.

Items F4 thru F7.

ADOPTED: MAR 28 2017
(DATE)

PRESIDING OFFICER
DEKALB COUNTY BOARD OF
COMMISSIONERS

CERTIFIED: MAR 28 2017
(DATE)

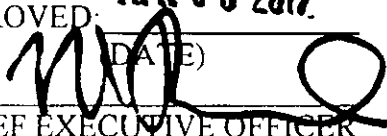
CLERK,
DEKALB COUNTY BOARD
OF COMMISSIONERS

FOR USE BY CHIEF EXECUTIVE OFFICER ONLY

APPROVED: APR 05 2017
(DATE)

CHIEF EXECUTIVE OFFICER
DEKALB COUNTY

VETOED: _____
(DATE)
CHIEF EXECUTIVE OFFICER
DEKALB COUNTY

VETO STATEMENT ATTACHED: _____

MINUTES:

FOR : Kathie Gannon, Steve Bradshaw, Gregory Adams, Nancy Jester, Larry Johnson, Mereda Davis Johnson, Jeff Rader

AGAINST : None

ABSTAIN : None

ABSENT : None

Patrick Medley
4859 Brasac Drive, Stone Mountain, GA 30083 • (404) 299 – 2727 • pmedley22@yahoo.com

PROFESSIONAL SUMMARY

Well-organized and effective program administrator with demonstrated interpersonal skills in working with private and public sector organizations. Proven excellence with innovative program development, implementation, and evaluation. Strong proactive background in providing guidance, counseling, and strategic concrete opportunities to youth and their families. Experience in hiring, training, supervising, and advising program personnel. Excellent oral and written communication skills.

EDUCATION:

Graduate Certificate, Gerontology

Georgia State University, Atlanta, Georgia

B.A., Human Relations

High Point University, High Point, North Carolina

A.A., Social Studies

Lees McRae College, Banner Elk, North Carolina

PROFESSIONAL HISTORY:

CRISTO REY ATLANTA JESUIT HIGH SCHOOL

October 2013 –

Dean of Students

- Support School Principal in creating and managing school culture.
- Facilitate and Manage detention program.
- Maintain and foster communication with staff, students, parents, students, and volunteers.
- Teach Health and Physical Education.
- Collaborate with School Counselor regarding student services.
- Serve on Admissions Committee
- Coordinator of Crisis Management Team
- Serve on Accreditation Committee

Admissions Coordinator

- Manage operational procedures in Admissions Department.
- Maintain student database.
- Coordinate, Plan, and Facilitate recruitment events.
- Build and Foster relationships with community partners.
- Direct student recruitment task force.

SENIOR CONNECTIONS, INC., ATLANTA, GA**August 2012 – January 2013****Senior Center Manager**

- Planned and coordinated social/educational activities.
- Managed day to day operations of Senior Center.
- Formed effective collaborations with volunteers and community agencies.
- Trained and supervised staff and members.
- Adhered to agency, state, and federal standards.
- Compiled data for weekly and monthly reports.

PATH ACADEMY CHARTER SCHOOL, ATLANTA, GA**August 2004-August 20012****Health and Physical Education Teacher**

- Taught and promoted Health and Physical Education to diverse population.
- Engaged students in the classroom to maximize effectiveness and learning experience.
- Found innovative ways to motivate at risk students to improve dropout rate and increase AYP.
- Coached basketball.

BOYS & GIRLS CLUBS OF METRO ATLANTA, ATLANTA, GA**Assistant Director of College Bound****September 2002 – August 2004**

- Promoted higher education through colleges and universities to teens.
- Successfully served as a resource for Club Staff in the development and implementation of educational Curriculum for middle school and high school programs.
- Prepared youth for higher education and assists them in identifying and obtaining resources for high education.
- Tracked progress and implementation to improve program's success.

BOYS & GIRLS CLUB OF METRO ATLANTA, ATLANTA, GA**Program Director****June 2002 – September 2003**

- Managed and implemented overall program services within club.
- Completed required training credits for acceptance to Boys & Girls Club Professional Academy.
- Maintained effective and efficient use of agency physical and financial resources.
- Supervised and trained up staff and volunteers.
- Advised stakeholders of current trends.

BOYS & GIRLS CLUBS OF GREATER HIGHPOINT, HIGHPOINT, NC**Unit Director****November 2001 – June 2002**

- Managed the development and opening of the first Boys & Girls Club in the City of Asheboro and Randolph County.
- Directed an \$85000 BA grant from Boys & Girls Clubs of America.
- Recruited, trained and supervised all Club staff and volunteers.
- Promptly submitted accurate personnel, administrative, and program reports.

- Initiated new in-school services to promote, improve, and maintain beneficial levels of academic achievement of club members.
- Formed partnerships with the Arts Guild, Chamber of Commerce, Police Department, Asheboro City Schools, Fire Department, 4H, etc.
- Developed and promoted several effective marketing tools that increased participation by 40%.
- Implemented and monitored innovative programs in areas of Vital Life Decisions, and Success in Schools.
- Completed several national management training workshops.

INSTITUTE FOR FAMILY CENTERED SERVICES, RICHMOND, VA

Family Service Coordinator

February 2000 – November 2001

- Provided court-ordered direct and referral services to diverse families in crisis.
- Served as a foster care and court representative for families.
- Provided supportive services with families and individuals with emphasis on education, modeling, and provision of useful and concrete options based on the needs of the family.
- Promptly submitted required reports and plans of service for clients.

COMMUNITY SERVICE:

High Point Hospital – Unhealthy Adolescent Behavior Task Force
 High Point YWCA – Adolescent Parenting Program Advisory Board
 High Point Communities in Schools – “Partner” Volunteer for 3 years
 High Point Parks and Recreation – Special Olympics Volunteer
 High Point United Way – Project Blue Print Graduate
 Atlanta Regional Commission-Atlanta
 American Red Cross - Atlanta
 Hosea Feed the Hungry – Atlanta
 Meals on wheels- Atlanta
 DeKalb County Government – Atlanta

AWARDS

•
 Outstanding Graduate Certificate Student in Gerontology-Georgia State University
 Who's who among American Junior College Students-Lees McRae College
 Outstanding College Students of America- High Point University
 Professional Development for best overall file system– Richmond Institute for Family Centered Services
 High Point Housing Authority Pillar of Fame recipient

Patrick D. Medley
4859 Brasac Drive, Stone Mountain, GA 30083 • (404)299-2727 • pmedley22@yahoo.com

REFERENCES

Mr. James Bethea Ph.D

Associate Professor
St. John's University
8000 Utopia Parkway
Queens, NY 11439
(347)752-0757

Mrs. Suttiwan Cox

PATH Academy Charter School
3007 Hermance Drive
Atlanta, GA 30319
(404)816-2135

Ms. Hazel Gonzalez

Director of Center Managers
Senior Connections
5238 Peachtree Rd.
Atlanta, GA 30341
(404)353-8971

Mr. Stephen Morris M.P.A.

Regional Manager
Boys & Girls Clubs of America
P. O. Box 2834
High Point, NC 27261
(336)431-9591

Ms. Wendy Rivers M.A.L.S.

Executive Director
Big Brothers & Big Sisters of Central Piedmont
P.O. Box 627
High Point, NC 27261
(336)882-4167

DEKALB COUNTY

ITEM NO. F7

BOARD OF COMMISSIONERS

BUSINESS AGENDA / MINUTES

MEETING DATE: March 28, 2017

HEARING TYPE
Appointment

ACTION TYPE
Resolution

SUBJECT: To Record the Appointment of Nicole M. Golden to Position of Chief Deputy Tax Commissioner

DEPARTMENT: Tax Commissioner

PUBLIC HEARING: YES NO

ATTACHMENT: YES No
PAGES: 5

INFORMATION CONTACT: Commissioner Irvin J. Johnson
Tax Commissioner
PHONE NUMBER: 404-298-4000

PURPOSE:

To record the appointment of Nicole M. Golden as Chief Deputy Tax Commissioner for DeKalb County.

NEED/IMPACT:

In accordance with the requirement set forth in O.C.G.A. 48-5-128 for the sole purpose of appointing a successor to fill an unexpired term of the Tax Commissioner should a vacancy occur, or if for any reason, the Tax Commissioner is unable to serve a complete term of office, Irvin J. Johnson, Tax Commissioner of DeKalb County, Georgia, appoints Nicole M. Golden as Chief Deputy Tax Commissioner of DeKalb County, Georgia. This serves as the recording of the notice of this appointment by the Tax Commissioner in the official minutes of the Board of Commissioners as required by code.

RECOMMENDATION(S):

To direct the Clerk to record this appointment of Nicole M. Golden as Chief Deputy Tax Commissioner for DeKalb County.

FOR USE BY COMMISSION OFFICE/CLERK ONLY

ACTION : 2017-03-28 Item F7

MOTION was made by Jeff Rader, seconded by Gregory Adams and passed 7-0-0-0 to approve to direct the Clerk to record the appointment of Nicole M. Golden as Chief Deputy Tax Commissioner for DeKalb County.

Items F4 thru F7.

ADOPTED: MAR 28 2017
(DATE)
Kathie Gannon
PRESIDING OFFICER
DEKALB COUNTY BOARD OF
COMMISSIONERS

CERTIFIED: MAR 28 2017
(DATE)
Barbara A. Gaud
CLERK,
DEKALB COUNTY BOARD
OF COMMISSIONERS

FOR USE BY CHIEF EXECUTIVE OFFICER ONLY

APPROVED: APR 05 2017
(DATE)
[Signature]
CHIEF EXECUTIVE OFFICER
DEKALB COUNTY

VETOED: _____
(DATE)
CHIEF EXECUTIVE OFFICER
DEKALB COUNTY

VETO STATEMENT ATTACHED: _____

MINUTES:

FOR : Kathie Gannon, Steve Bradshaw, Gregory Adams, Nancy Jester, Larry Johnson, Mereda Davis Johnson, Jeff Rader

AGAINST : None

ABSTAIN : None

ABSENT : None



IRVIN J. JOHNSON

Tax Commissioner
DeKalb County, GA

F7

Office of the Tax Commissioner

Andrew G. Booth, Assistant Tax Commissioner
Nicole M. Golden, Chief Deputy Tax Commissioner

MEMORANDUM

TO: Michael L. Thurmond, Chief Executive Officer
Nancy Jester, District 1 Commissioner
Jeff Rader, District 2 Commissioner
Larry Johnson, District 3 Commissioner
Steve Bradshaw, District 4 Commissioner
Mereda Davis Johnson, District 5 Commissioner
Kathie Gannon, District 6 Commissioner
Gregory Adams, District 7 Commissioner

FROM: Irvin J. Johnson, Tax Commissioner

SUBJECT: Appointment of Chief Deputy Tax Commissioner

DATE: January 3, 2017

In accordance with the requirement set forth in O.C.G.A. 48-5-128.1, I hereby make notification to the County governing authority that Nicole M. Golden is my sworn and appointed Chief Deputy Tax Commissioner as of December 8, 2016, recorded in Book 3058 Page 105 of the DeKalb County Probate Court.

As referenced in the code section above, the purpose of this appointment is to create succession to fill my unexpired term should a vacancy occur in the office of Tax Commissioner, or if for any reason, I am unable to serve my complete term of office.

I have attached a copy of the recorded appointment of Nicole M. Golden as Chief Deputy Tax Commissioner as well as O.C.G.A 48-5-128.1, which requires that I notify you of this appointment. The code section also requires that the County governing authority shall record a copy of the new appointment upon its minutes.

If you need further information or assistance, please contact me at 404-298-3020.

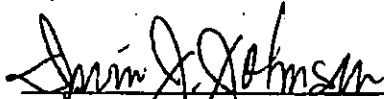
Irvin J. Johnson, Tax Commissioner

IJJ/adc

Attachments

CC: Barbara H. Sanders, Clerk Board of Commissioners



**OFFICIAL APPOINTMENT AND OATH
OF CHIEF DEPUTY TAX COMMISSIONER**

FILED
2016 DEC -8 PM 4:40
DEKALB CO. PROBATE COURT

GEORGIA, DEKALB COUNTY

I, **Irvin J. Johnson**, as duly elected Tax Commissioner of DeKalb County, Georgia, do hereby appoint **Nicole M. Golden** as Chief Deputy Tax Commissioner of DeKalb County, Georgia. This appointment is made according to the provisions of the Official Code of Georgia Annotated, 48-5-128.1., for the sole purpose of appointing a successor to fill my unexpired term of office should a vacancy occur in the office of Tax Commissioner, or if for any reason, I am unable to serve my complete term of office.

I hereby revoke all other appointments to Chief Deputy Tax Commissioner heretofore made by me. This appointment is effective December 8, 2016 and shall continue in full force and effect during the term of my office, including all my succeeding terms of office, or until such appointment is revoked by myself, or a successor is appointed and duly qualified.

This 8th day of December, 2016.

Irvin J. Johnson, Tax Commissioner
DeKalb County, Georgia

I, **Nicole M. Golden**, who being sworn and having accepted the duties of Chief Deputy Tax Commissioner of DeKalb County, Georgia, as contained in the afore-mentioned appointment, do solemnly swear that I will faithfully discharge the duties required of me as Chief Deputy Tax Commissioner and that I will diligently collect and pay over all taxes as required by law. I do further affirm that I have met all the qualifications required of me by law to assume the appointment of Chief Deputy Tax Commissioner. SO HELP ME GOD!

Nicole M. Golden

Sworn to and subscribed before me
This 8th day of December, 2016

Jeryl Kosh
Judge of the Probate Court
DeKalb County, Georgia

EX 3058 PG 104

Document:O.C.G.A. § 48-5-128.1

O.C.G.A. § 48-5-128.1

Copy Citation

Current Through the 2016 Regular Session

**Official Code of Georgia Annotated TITLE 48. REVENUE AND
TAXATION CHAPTER 5. AD VALOREM TAXATION OF
PROPERTY ARTICLE 3. COUNTY TAX OFFICIALS AND
ADMINISTRATION PART 2. TAX COLLECTORS**

§ 48-5-128.1. Appointment in certain counties of chief deputy tax commissioner; filling vacancy in office of chief deputy; succession to office of tax commissioner

(a) In all counties of this state having a population of 550,000 or more according to the United States decennial census of 1950 or any future such census and in which there exists the office of tax commissioner, the tax commissioner shall be required to appoint from among the assistants or deputies in his office a chief deputy. Upon making the appointment, the tax commissioner shall notify the county governing authority, which shall record a copy of the appointment upon its minutes. The tax commissioner shall appoint the chief deputy at his will and pleasure, such appointment in no event to extend beyond the term of office of the person making the appointment.

(b) If the person appointed as chief deputy resigns, if the appointment is revoked, or if for any other reason the appointment is vacant, the tax commissioner shall appoint a new chief deputy and shall notify the county

governing authority of the new appointment. The county governing authority shall record a copy of the new appointment upon its minutes.

(c) If a vacancy occurs in the office of tax commissioner in any county specified in subsection (a) of this Code section, the person appointed as chief deputy by the tax commissioner and certified to the county governing authority, upon qualifying for the office of tax commissioner in the manner provided by law, shall succeed to the office of tax commissioner and fill the unexpired term of the tax commissioner of the county.

History

Code 1981, § 48-5-128.1, enacted by Ga. L. 1982, p. 2107, § 49.

▼ Annotations

Research References & Practice Aids

Hierarchy Notes:

Title Note

Hierarchy Notes:

Chapter Note

Hierarchy Notes:

Article Note

Hierarchy Notes:

Part Note

OFFICIAL CODE OF GEORGIA ANNOTATED

F7

Copyright 2016 by The State of Georgia All rights reserved.

Content Type:

Terms:

Narrow By: -None-

Date and Time: Dec 30, 2016 . 12:11:22 p.m. EST

 LexisNexis® [About LexisNexis®](#) [Privacy Policy](#) [Terms & Conditions](#) [Sign Out](#)

Copyright © 2016 LexisNexis. All rights reserved.

 RELX Group™

DEKALB COUNTY

ITEM NO. G1

BOARD OF COMMISSIONERS

HEARING TYPE
Preliminary

BUSINESS AGENDA / MINUTES

ACTION TYPE
RESOLUTION

MEETING DATE: March 28, 2017

SUBJECT: To Transfer \$200,000.00 from 2001 Parks Bond District 3 Account 100599.80314.541200.06.600021 to set up a Project account in the 2001 Parks Bond District 3 Award for the Ellenwood Park Project

DEPARTMENT: Board of Commissioners

PUBLIC HEARING: YES NO

ATTACHMENT: YES No
PAGES: 0

INFORMATION CONTACT: Larry Johnson
District 3 Commissioner
PHONE NO: (404)371-2425

PURPOSE:

To transfer \$200,000 from 2001 Parks Bond District 3 account 100599.80314.541200.06.600021 to set up a project account in the 2001 Parks Bond District 3 award for the new Ellenwood Park Project.

NEED/IMPACT:

This funding is needed for development at the new Ellenwood Park.

5109 2 9 2017

RECOMMENDATION(S):

Recommend that funds in the amount of \$200,000.00 be transferred from 2001 Parks Bond District 3 account 100599.80314.541200.06.600021 to set up a project for Ellenwood Park: and authorize the Chief Executive Officer to execute all the necessary documents and contracts for the completion of the project.

FOR USE BY COMMISSION OFFICE/CLERK ONLY

ACTION : 2017-03-28 ItemG1

MOTION was made by Jeff Rader, seconded by Nancy Jester and passed 7-0-0-0 to approve to recommend that funds in the amount of \$200,000.00 be transferred from 2001 Parks Bond District 3 account 100599.80314.541200.06.600021 to set up a project for Ellenwood Park: and authorize the Chief Executive Officer to execute all the necessary documents and contracts for the completion of the project.

Items G1 thru G7 were heard together.

ADOPTED: MAR 28 2017
(DATE)

Kathie Gannon

PRESIDING OFFICER
DEKALB COUNTY BOARD OF
COMMISSIONERS

CERTIFIED: MAR 28 2017
(DATE)

Robert J. Grier

CLERK,
DEKALB COUNTY BOARD
OF COMMISSIONERS

FOR USE BY CHIEF EXECUTIVE OFFICER ONLY

APPROVED: APR 05 2017
(DATE)

NO

CHIEF EXECUTIVE OFFICER
DEKALB COUNTY

VETOED: _____
(DATE)

CHIEF EXECUTIVE OFFICER
DEKALB COUNTY

VETO STATEMENT ATTACHED: _____

MINUTES:

FOR : Kathie Gannon, Steve Bradshaw, Gregory Adams, Nancy Jester, Larry Johnson, Mereda Davis Johnson, Jeff Rader

AGAINST : None

ABSTAIN : None

ABSENT : None

BOARD OF COMMISSIONERS

BUSINESS AGENDA / MINUTES

MEETING DATE: March 28, 2017

HEARING TYPE
Preliminary

ACTION TYPE
Resolution

SUBJECT: Allocate District 7 Park Bond Funds for the Repair & Preservation of All Historical Farm Buildings and Cabin at the Chapman Mill/Redan Park Nature Preserve

DEPARTMENT Board of Commissioners

PUBLIC HEARING: YES NO

ATTACHMENT YES No

INFORMATION Commissioner Gregory Adams

CONTACT:

PAGES: 2

PHONE NUMBER: (404) 371-3681

PURPOSE:

To provide a total of \$14,900 to be derived from the District 7 Park Bond account to repair and bring up to code the electrical wiring in the farm buildings, to protect the historic structures located on the Chapman Mill/Redan Park Nature Preserve site located at 5354 Redan Road in Stone Mountain.

NEED/IMPACT:

According to Fernbank Science Center Ornithologist Christopher R. Showalter, "In addition to its value to birds and other wildlife, the site represents an opportunity to engage local school children and adults from this urban community in understanding the value of conversation, as well as biology and environmental science."

RECOMMENDATION(S):

Authorize the Allocation of District 7 Park Bond Funds for the Preservation of the Chapman Mill/Redan Park Nature Preserve.

FOR USE BY COMMISSION OFFICE/CLERK ONLY

ACTION : 2017-03-28 ItemG2

MOTION was made by Jeff Rader, seconded by Nancy Jester and passed 7-0-0 to approve the Authorization of the Allocation of District 7 Park Bond Funds for the Preservation of the Chapman Mill/RedanPark Nature Preserve.

Items G1 thru G7 were heard together.

ADOPTED: MAR 28 2017
(DATE)

Kathie Gannon

PRESIDING OFFICER
DEKALB COUNTY BOARD OF
COMMISSIONERS

CERTIFIED: MAR 28 2017

(DATE)
Robert L. Grier

CLERK,
DEKALB COUNTY BOARD
OF COMMISSIONERS

FOR USE BY CHIEF EXECUTIVE OFFICER ONLY

APPROVED: APR 05 2017
(DATE)

W. O.

CHIEF EXECUTIVE OFFICER
DEKALB COUNTY

VETOED: _____
(DATE)

CHIEF EXECUTIVE OFFICER
DEKALB COUNTY

VETO STATEMENT ATTACHED: _____

MINUTES:

FOR : Kathie Gannon, Steve Bradshaw, Gregory Adams, Nancy Jester, Larry Johnson, Mereda Davis Johnson, Jeff Rader

AGAINST : None

ABSTAIN : None

ABSENT : None

Dear Commissioner Adams:

It was a pleasure meeting with you and your staff on Wednesday February 8, 2017 to discuss funding the Historic Farm at the Redan Nature Preserve located at 5354 Redan Road. According to Fernbank Science Center Ornithologist Christopher R. Showalter, "In addition to its value to birds and other wildlife, the site represents an opportunity to engage local school children and adults from this urban community in understanding the value of conversation, as well as biology and environmental science."

Attached please find a list of repairs needed for the Historic Farm House and additional buildings on the 9.2 acre site. Roof replacement on farm house and additional buildings are the number one priority right now. I have also attached our tax exempt documents for the Chapman Mill/Redan Park Community Development Corporation (CDC).

The CDC is governed by a seven member board of directors. I serve as board chair, and Evora Ritchie serves as treasurer. The CDC bank account is with Wells Fargo Bank, 4798 Redan Road, Stone Mountain, GA 30088. Please Make checks out to the Chapman Mill/Redan Park CDC.

I look forward to hearing back from you soon, and please let me know when I can schedule a site visit for you and your staff. Please let me know if I can answer additional questions, or provide additional information.

Calvin E. Sims, Sr., MPA, Board Chair: Chapman Mill/Redan Park Community Development Corporation (CDC)

Estimates For Restoring all Historic Farm Buildings and Cabin at Redan Nature Preserve

Six feet chain length fence 2600 ft around property	23,900.00
Roof top solar energy system farm buildings	29,000.00
Bringing electrical wiring up to code in all farm buildings	14,900.00
Removing and replacing all roof shingles on all structures	79,890.00
Painting interior/exterior-main building-guest house- cabin	25,080.00
 Sub Total	 172,770.00

Note does not include quote for carpeting main farm house
Note does not include quote for emergency fire sprinkler system if required
Note does not include quote for replacement of hot water tank and HVAC System in Historic Farm House

DEKALB COUNTY

ITEM NO. G3

BOARD OF COMMISSIONERS

BUSINESS AGENDA / MINUTES

MEETING DATE: March 28, 2017

HEARING TYPE
Preliminary

ACTION TYPE
Resolution

SUBJECT: Keystone Park Sign Topper Placement
Commission District 3, 6

DEPARTMENT: Public Works - Roads & Drainage

PUBLIC HEARING: YES NO

ATTACHMENT: YES No
VOS # 2 RAM
PAGES: 1

INFORMATION Peggy Allen/
CONTACT: VOS Roads and Drainage
(404) 294-2878
PHONE NUMBER: *[Handwritten signature]*

PURPOSE:

To approve placement of Keystone Park (Sign Toppers) signage within DeKalb County right-of-way to identify the Keystone Park neighborhood,

NEED/IMPACT:

The installation of the Sign Toppers will serve to identify the Keystone Park neighborhood to the traveling public. The area residents have hired Conley Signs Inc.; Sign A Rama-Decatur, who has provided the necessary insurance documentation and will bear the responsibility of installing and maintaining the signs. The signage will be permitted by Public Works-Roads and Drainage as a utility permit. The signs will be installed on existing street signs within the Keystone Park neighborhood.

RECOMMENDATION(s):

Approve placement of Keystone Park (Sign Toppers) signage within DeKalb County right-of-way to identify the Keystone Park neighborhood.

FOR USE BY COMMISSION OFFICE/CLERK ONLY

ACTION : 2017-03-28 ItemG3

MOTION was made by Jeff Rader, seconded by Nancy Jester and passed 7-0-0-0 to approve the placement of Keystone Park (Sign Toppers) signage within DeKalb County right-of-way to identify the Keystone Park neighborhood.

Items G1 thru G7 were heard together.

ADOPTED: MAR 28 2017
(DATE)

Kathie Gannon
PRESIDING OFFICER
DEKALB COUNTY BOARD OF
COMMISSIONERS

CERTIFIED: MAR 28 2017
(DATE)

Barbara A. Gaud
CLERK,
DEKALB COUNTY BOARD
OF COMMISSIONERS

FOR USE BY CHIEF EXECUTIVE OFFICER ONLY

APPROVED: APR 05 2017
(DATE)

[Signature]
CHIEF EXECUTIVE OFFICER
DEKALB COUNTY

VETOED: _____
(DATE)

CHIEF EXECUTIVE OFFICER
DEKALB COUNTY

VETO STATEMENT ATTACHED: _____

MINUTES:

FOR : Kathie Gannon, Steve Bradshaw, Gregory Adams, Nancy Jester, Larry Johnson, Mereda Davis Johnson, Jeff Rader

AGAINST : None

ABSTAIN : None



ABSENT : None

DeKalb County, GA

Roads & Drainage Dept.

Commissioner District 3
Super District 6

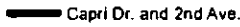
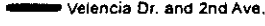
Legend

-  Longdale Dr. and 2nd Ave.
-  Capri Dr. and 2nd Ave.
-  Velencia Dr. and 2nd Ave.
-  Keystone Dr. and Valencia Rd
-  Joseph Court and 2nd Ave.

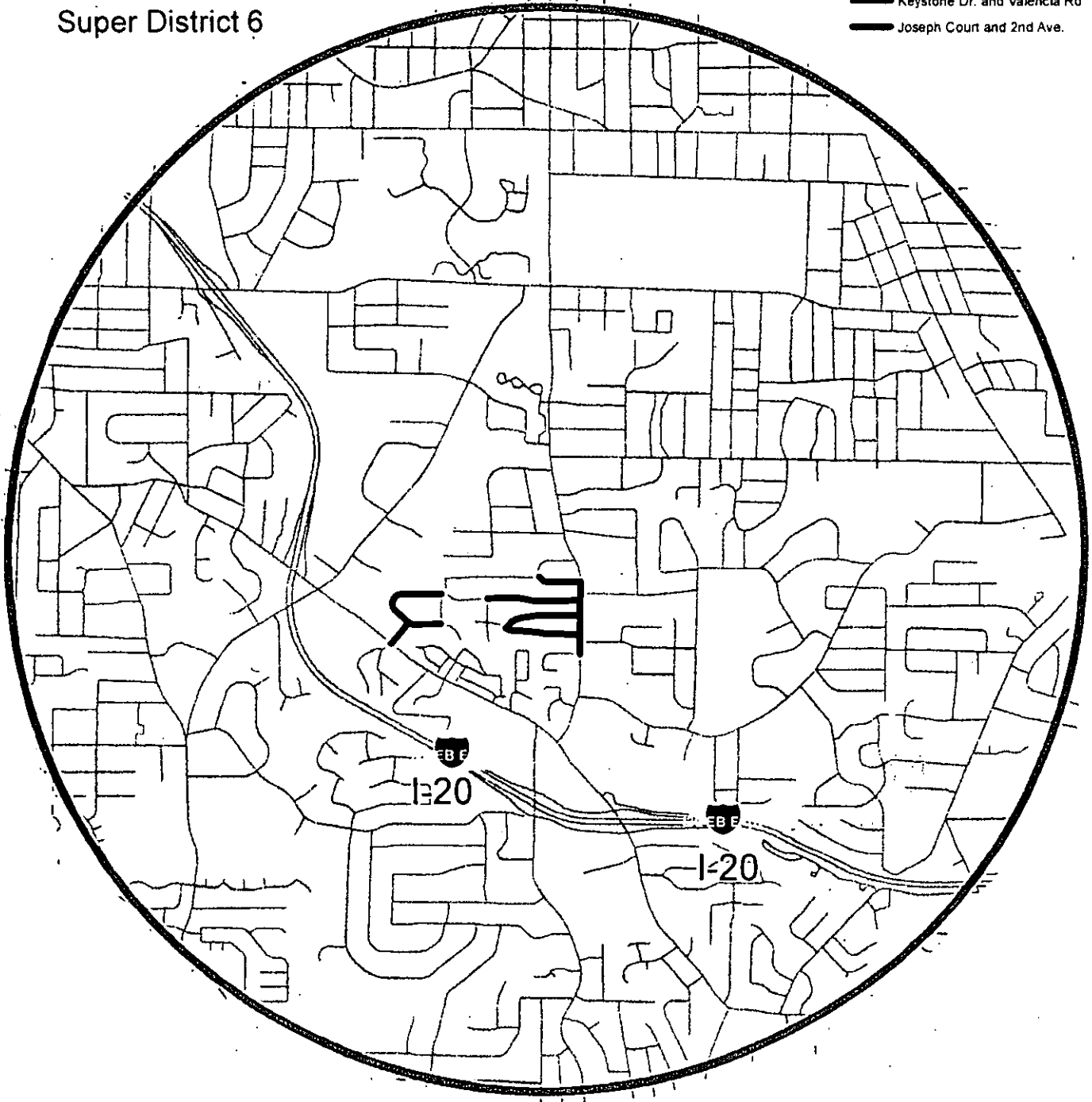

Keystone Park

Map Source: Roads & Drainage GIS
Date: As of January 2017



CEO: Mike Thurmond

Commissioners

- District 1: Nancy Jester
- District 2: Jeff Rader
- District 3: Larry Johnson
- District 4: Steve Bradshaw
- District 5: Marreda Davis-Johnson
- Super District 6: Kathie Gannon
- Super District 7: Gregory Adams, Sr.

ITEM NO. G4

BOARD OF COMMISSIONERS

BUSINESS AGENDA / MINUTES

MEETING DATE: March 28, 2017

HEARING TYPE
Preliminary

ACTION TYPE
Resolution

SUBJECT: Cavalier Gardens Sign Topper Placement
Commission District 3, 6

DEPARTMENT: Public Works – Roads & Drainage

PUBLIC HEARING: YES NO

ATTACHMENT: YES No

PAGES: 1 3 4 5

INFORMATION CONTACT: Peggy Allen/
Roads and Drainage
PHONE NUMBER: (404) 294-2878

PURPOSE:

To approve placement of Cavalier Gardens (Sign Toppers) signage within DeKalb County right-of-way to identify the Cavalier Gardens neighborhood,

NEED/IMPACT:

The installation of the Sign Toppers will serve to identify the Cavalier Gardens neighborhood to the traveling public. The area residents have hired Conley Signs Inc; Sign A Rama-Decatur, who has provided the necessary insurance documentation and will bear the responsibility of installing and maintaining the signs. The signage will be permitted by Public Works-Roads and Drainage as a utility permit. The signs will be installed on existing street signs within the Cavalier Gardens neighborhood.

RECOMMENDATION(s):

Approve placement of Cavalier Gardens (Sign Toppers) signage within DeKalb County right-of-way to identify the Cavalier Gardens neighborhood.

FOR USE BY COMMISSION OFFICE/CLERK ONLY

ACTION : 2017-03-28 ItemG4

MOTION was made by Jeff Rader, seconded by Nancy Jester and passed 7-0-0-0 to approve the placement of Cavalier Gardens (Sign Toppers) signage within DeKalb County right-of-way to identify the Cavalier Gardens neighborhood.

Items G1 thru G7 were heard together.

ADOPTED: MAR 28 2017
(DATE)

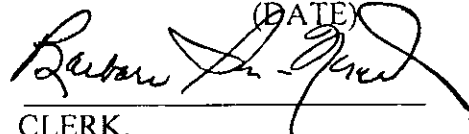
PRESIDING OFFICER
DEKALB COUNTY BOARD OF
COMMISSIONERS

CERTIFIED: MAR 28 2017
(DATE)

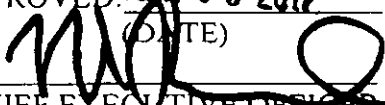
CLERK,
DEKALB COUNTY BOARD
OF COMMISSIONERS

FOR USE BY CHIEF EXECUTIVE OFFICER ONLY

APPROVED: APR 05 2017
(DATE)

CHIEF EXECUTIVE OFFICER
DEKALB COUNTY

VETOED: _____
(DATE)

CHIEF EXECUTIVE OFFICER
DEKALB COUNTY

VETO STATEMENT ATTACHED: _____

MINUTES:

FOR : Kathie Gannon, Steve Bradshaw, Gregory Adams, Nancy Jester, Larry Johnson, Mereda Davis Johnson, Jeff Rader

AGAINST : None

ABSTAIN : None

ABSENT : None

DeKalb County, GA

Roads & Drainage Dept.

Commissioner District 3
Super District 6

G4

Legend

- Williamsburg Way and Cavalier Way
- Williamsburg Way and Williamsburg Dr.
- Williamsburg Way and Flat Shoals Rd.
- Cavalier Dr. and Lloyd Rd.
- Williamsburg Dr. and Lloyd Rd.
- Jamestown Way and Williamsburg Dr.
- Jamestown Way and Preston Dr.
- Cavalier Dr. and Jamestown Way
- Cavalier Dr. and Preston Dr.
- Cavalier Dr. and Quincy Ln.
- Cavalier Dr. and Williamsburg Dr.
- Cavalier Dr. and Cavalier Way

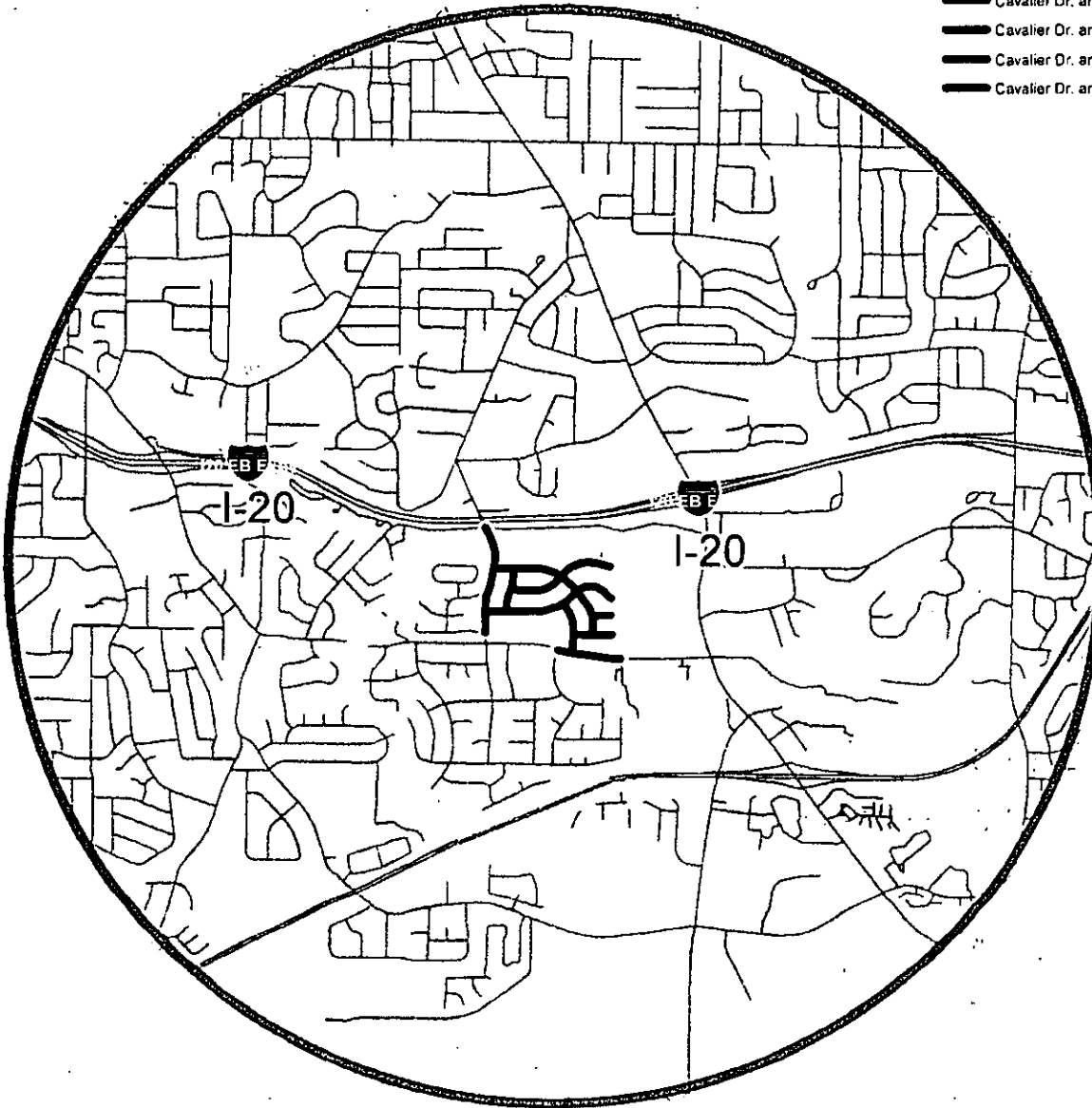

Cavalier Gardens

Map Source: Roads & Drainage GIS
Date: As of January 2017



CEO: Mike Thurmond

Commissioners
 District 1: Nancy Jester
 District 2: Jeff Rader
 District 3: Larry Johnson
 District 4: Steve Bradshaw
 District 5: Mercede Davis-Johnson
 Super District 6: Kathie Gannon
 Super District 7: Gregory Adams, Sr.

DEKALB COUNTY

ITEM NO. G5

BOARD OF COMMISSIONERS

BUSINESS AGENDA / MINUTES

MEETING DATE: March 28, 2017

HEARING TYPE
Preliminary

ACTION TYPE
Resolution

SUBJECT: Highland Park Sign Topper Placement
Commission District 3, 6

DEPARTMENT: Public Works – Roads & Drainage

PUBLIC HEARING: YES NO

ATTACHMENT: YES No
PAGES: 1

INFORMATION Peggy Allen/
CONTACT: Roads and Drainage
(404) 294-2878
PHONE NUMBER:

PURPOSE:

To approve placement of Highland Park (Sign Toppers) signage within DeKalb County right-of-way to identify the Highland Park neighborhood,

NEED/IMPACT:

The installation of the Sign Toppers will serve to identify the Highland Park neighborhood to the traveling public. The area residents have hired Conley Signs Inc; Sign A Rama-Decatur, who has provided the necessary insurance documentation and will bear the responsibility of installing and maintaining the signs. The signage will be permitted by Public Works-Roads and Drainage as a utility permit. The signs will be installed on existing street signs within the Highland Park neighborhood.

RECOMMENDATION(s):

Approve placement of Highland Park (Sign Toppers) signage within DeKalb County right-of-way to identify the Highland Park neighborhood.

FOR USE BY COMMISSION OFFICE/CLERK ONLY

ACTION : 2017-03-28 ItemG5

MOTION was made by Jeff Rader, seconded by Nancy Jester and passed 7-0-0-0 to approve the placement of Highland Park (Sign Toppers) signage within DeKalb County right-of-way to identify the Highland Park neighborhood.

Items G1 thru G7 were heard together.

ADOPTED: MAR 28 2017
(DATE)

Kathie Gannon

PRESIDING OFFICER
DEKALB COUNTY BOARD OF
COMMISSIONERS

CERTIFIED: MAR 28 2017
(DATE)

Barbara L. Gann

CLERK,
DEKALB COUNTY BOARD
OF COMMISSIONERS

FOR USE BY CHIEF EXECUTIVE OFFICER ONLY

APPROVED: APR 05 2017
(DATE)

W. O.

CHIEF EXECUTIVE OFFICER
DEKALB COUNTY

VETOED: _____
(DATE)

CHIEF EXECUTIVE OFFICER
DEKALB COUNTY

VETO STATEMENT ATTACHED: _____

MINUTES:

FOR : Kathie Gannon, Steve Bradshaw, Gregory Adams, Nancy Jester, Larry Johnson, Mereda Davis Johnson, Jeff Rader

AGAINST : None

ABSTAIN : None

ABSENT : None

DeKalb County, GA

Roads & Drainage Dept.

Commissioner District 3
Super District 6

- Legend**
- Hsbersham Dr. and Starline Dr. G5
 - Haverford Dr. and Tison Rd.
 - Tison Rd. and Candler Rd.
 - Tison Rd. and 2nd Ave.
 - Mark Trl. and Tison Rd.
 - Parkland Dr. and Tison Rd.
 - Tison Cr. and Tison Rd. (Near N.H. Scott Park)
 - Tison Cr. and Tison Rd.
 - Dawn Dr. and Tison Rd.
 - Tyler Way and Tison Rd.
 - Fair Ln. and Tison Rd.
 - Starline Dr. and Tison Rd.
 - Bixler Cr. and Tison Rd.
 - Collier Dr. and Tison Rd.
 - Windyhill Rd. and Tison Rd.

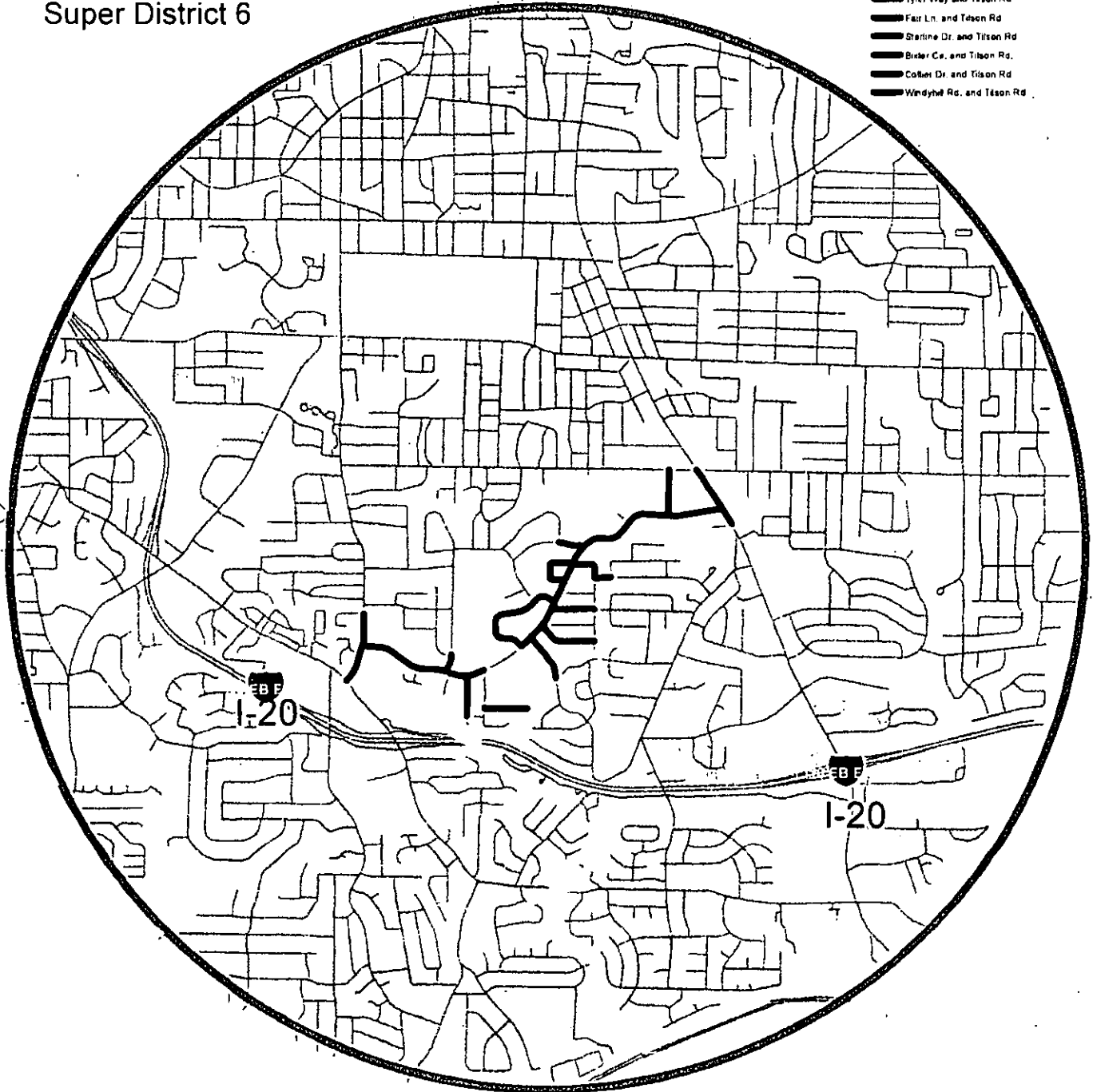

Highland Park

Map Source: Roads & Drainage GIS
Date: As of January 2017



CEO: Mike Thurmond

Commissioners

- District 1: Nancy Jester
- District 2: Jeff Rader
- District 3: Larry Johnson
- District 4: Steve Bradshaw
- District 5: Mercede Davis-Johnson
- Super District 6: Kathleen Gannon
- Super District 7: Gregory Adams, Sr.

ITEM NO. G6

BOARD OF COMMISSIONERS
BUSINESS AGENDA / MINUTES
MEETING DATE: March 28, 2017

HEARING TYPE
Preliminary

ACTION TYPE
Resolution

SUBJECT: Kelly Lake Sign Topper Placement
Commission District 3, 7

DEPARTMENT: Public Works – Roads & Drainage

PUBLIC HEARING: YES NO

ATTACHMENT: YES No
PAGES: 1

INFORMATION CONTACT: Peggy Allen/
Roads and Drainage
(404) 294-2878
PHONE NUMBER: [Handwritten Signature]

PURPOSE:

To approve placement of Kelly Lake (Sign Toppers) signage within DeKalb County right-of-way to identify the Kelly Lake neighborhood,

NEED/IMPACT:

The installation of the Sign Toppers will serve to identify the Kelly Lake neighborhood to the traveling public. The area residents have hired Conley Signs Inc; Sign A Rama-Decatur, who has provided the necessary insurance documentation and will bear the responsibility of installing and maintaining the signs. The signage will be permitted by Public Works-Roads and Drainage as a utility permit. The signs will be installed on existing street signs within the Kelly Lake neighborhood.

RECOMMENDATION(s):

Approve placement of Kelly Lake (Sign Toppers) signage within DeKalb County right-of-way to identify the Kelly Lake neighborhood.

FOR USE BY COMMISSION OFFICE/CLERK ONLY

ACTION : 2017-03-28 ItemG6

MOTION was made by Jeff Rader, seconded by Nancy Jester and passed 7-0-0-0 to approve the placement of Kelly Lake (Sign Toppers) signage within DeKalb County right-of-way to identify the Kelly Lake neighborhood.

Items G1 thru G7 were heard together.

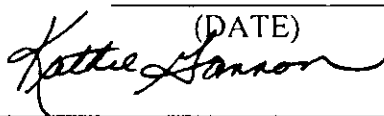
ADOPTED: MAR 28 2017
(DATE)

PRESIDING OFFICER
DEKALB COUNTY BOARD OF
COMMISSIONERS

CERTIFIED: MAR 28 2017
(DATE)

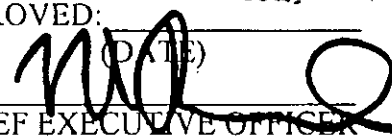
CLERK,
DEKALB COUNTY BOARD
OF COMMISSIONERS

FOR USE BY CHIEF EXECUTIVE OFFICER ONLY

APPROVED: APR 05 2017
(DATE)

CHIEF EXECUTIVE OFFICER
DEKALB COUNTY

VETOED: _____
(DATE)
CHIEF EXECUTIVE OFFICER
DEKALB COUNTY

VETO STATEMENT ATTACHED: _____

MINUTES:

FOR : Kathie Gannon, Steve Bradshaw, Gregory Adams, Nancy Jester, Larry Johnson, Mereda Davis Johnson, Jeff Rader

AGAINST : None

ABSTAIN : None

ABSENT : None

DeKalb County, GA

Roads & Drainage Dept.

Commissioner District 3
Super District 7

Legend

- Kelly Lake Rd. and Whites Mill Rd.
- Lloyd Rd. and Lloyd Ct.
- Lloyd Rd. and Pautone Trace
- Kelly Lake Rd. and Candler Wood Dr.
- Kelly Lake Rd. and Kelly Lake Dr. (Left Side)
- Kelly Lake Rd. and Kelly Lake Dr. (Right Side)
- Kelly Lake Rd. and Lloyd Rd.
- Whites Mill Rd. and Oak Village Trl.
- Yale Ter. and Whites Mill Rd.
- Kelly Lake Rd. and LaFortune Dr.
- Kelly Lake Dr. and LaFortune Dr.
- Kelly Lake Dr. and Candler Woods Way
- Kelly Lake Dr. and Ct.
- Candler Woods Dr. and Ct.

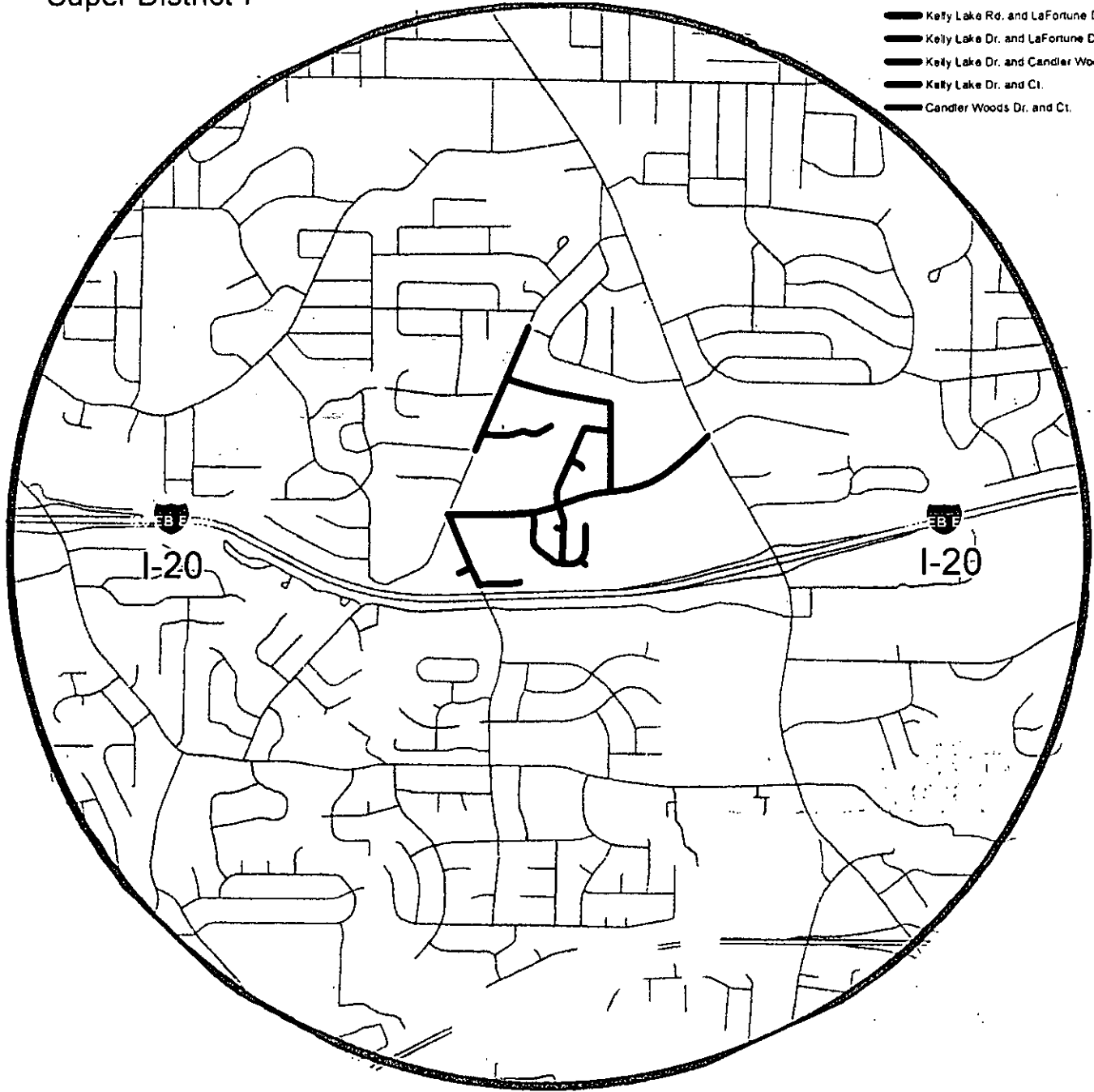

Kelly Lake

Map Source: Roads & Drainage GIS
Date: As of January 2017



CEO: Mike Thurmond

Commissioners

- District 1: Nancy Jester
- District 2: Jeff Rader
- District 3: Larry Johnson
- District 4: Steve Gresham
- District 5: Merida Davis-Johnson
- Super District 6: Kathie Gannon
- Super District 7: Gregory Adams, Sr.

ITEM NO. G7

BOARD OF COMMISSIONERS

HEARING TYPE
Preliminary

BUSINESS AGENDA / MINUTES

ACTION TYPE
Resolution

MEETING DATE: March 28, 2017

SUBJECT: Gresham Park Sign Topper Placement
Commission District 3, 7

DEPARTMENT: Public Works – Roads &
Drainage

PUBLIC HEARING: YES NO

ATTACHMENT: YES No
PAGES: 1

INFORMATION CONTACT: Peggy Allen/
Roads and Drainage
(404) 294-2878
PHONE NUMBER:

PURPOSE:

To approve placement of Gresham Park (Sign Toppers) signage within DeKalb County right-of-way to identify the Gresham Park neighborhood,

NEED/IMPACT:

The installation of the Sign Toppers will serve to identify the Gresham Park neighborhood to the traveling public. The area residents have hired Conley Signs Inc; Sign A Rama-Decatur, who has provided the necessary insurance documentation and will bear the responsibility of installing and maintaining the signs. The signage will be permitted by Public Works-Roads and Drainage as a utility permit. The signs will be installed on existing street signs within the Gresham Park neighborhood.

RECOMMENDATION(s):

Approve placement of Gresham Park (Sign Toppers) signage within DeKalb County right-of-way to identify the Gresham Park neighborhood.

FOR USE BY COMMISSION OFFICE/CLERK ONLY

ACTION : 2017-03-28 ItemG7

MOTION was made by Jeff Rader, seconded by Nancy Jester and passed 7-0-0-0 to approve the placement of Gresham Park (Sign Toppers) signage within DeKalb County right-of-way to identify the Gresham Park neighborhood.

Items G1 thru G7.

ADOPTED: MAR 28 2017
(DATE)
Kathie Gannon
PRESIDING OFFICER
DEKALB COUNTY BOARD OF
COMMISSIONERS

CERTIFIED: MAR 28 2017
(DATE)
Barbara L. Ginn
CLERK,
DEKALB COUNTY BOARD
OF COMMISSIONERS

FOR USE BY CHIEF EXECUTIVE OFFICER ONLY

APPROVED: APR 05 2017
(DATE)
[Signature]
CHIEF EXECUTIVE OFFICER
DEKALB COUNTY

VETOED: _____
(DATE)
CHIEF EXECUTIVE OFFICER
DEKALB COUNTY

VETO STATEMENT ATTACHED: _____

MINUTES:

FOR : Kathie Gannon, Steve Bradshaw, Gregory Adams, Nancy Jester, Larry Johnson, Mereda Davis Johnson, Jeff Rader

AGAINST : None

ABSTAIN : None











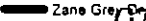



ABSENT : None

DeKalb County, GA

Roads & Drainage Dept.

Commissioner District 3
Super District 7

Legend

-  Zane Grey Dr
-  Wee Kirk Rd
-  Vicki Ln.
-  Tally Ho Dr.
-  Richard Allen Ln.
-  Parker Ranch Rd.
-  Mary Lou Lane/Bouldercrest Rd.
-  Lanier Way
-  Knight Ct.
-  Hallmark Ct.
-  Flintwood Dr.
-  Cottonwood Dr.
-  Clifton Church Rd./Gresham Rd.
-  Corral Ln.
-  Boulderview Dr.

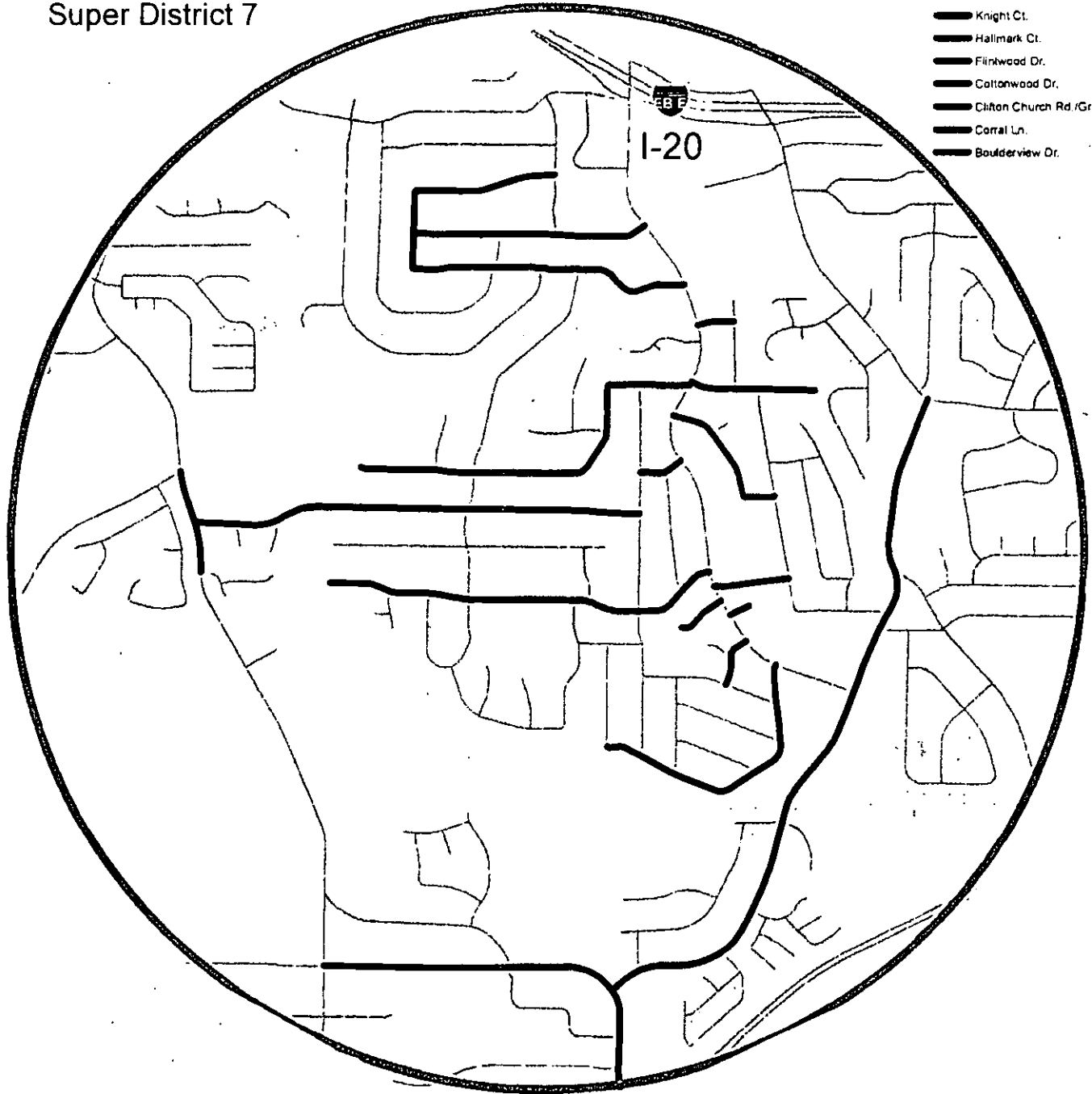

Gresham Park

Map Source: Roads & Drainage GIS
Date: As of January 2017



CEO: Mike Thurmond

Commissioners

- District 1: Nancy Jester
- District 2: Jeff Rader
- District 3: Larry Johnson
- District 4: Steve Bradshaw
- District 5: Mereda Davis-Johnson
- Super District 6: Kathie Gannon
- Super District 7: Gregory Adams, Sr.

DEKALB COUNTY

ITEM NO. HI

BOARD OF COMMISSIONERS
BUSINESS AGENDA / MINUTES
MEETING DATE: March 28, 2017

HEARING TYPE
Preliminary

ACTION TYPE
Resolution

AGENDA ITEM

SUBJECT: Group Health & Wellness Benefits effective July 1, 2017

DEPARTMENT: Finance

PUBLIC HEARING: YES NO

ATTACHMENT: YES NO
PAGES: 28

INFORMATION CONTACT: Zach Williams
Chief Operating Officer
PHONE NUMBER: (404) 371-2745

PURPOSE: To approve group health benefits rates for new plan year commencing July 1, 2017.

NEED/IMPACT:

To ensure the County is offering an affordable and valuable health plan for employees and retirees. The plan year for County employees and pre-65 retirees expires June 30, 2017.

The proposed healthcare costs and plan designs have been reviewed by the ERCS Committee.

RECOMMENDATION(S):

1. Recommend approval of BCBSGa's proposed administrative fee of \$40.50 PEPM which is unchanged from the current rate. Recommend approval of proposed Stop Loss insurance rate of \$72.50 PEPM.
2. Recommend approval of the proposed Kaiser fully insured rates for actives & early retirees with an 8.2% increase over current rates for actives and early retirees.
3. Accept the proposed Dental rates with a 7% increase over current rates.
4. Authorize the Chief Executive Officer to execute all necessary documents.

*PEPM - per employee per month

FOR USE BY COMMISSION OFFICE/CLERK ONLY

ACTION : 2017-03-28 ItemH1

MOTION was made by Mereda Davis Johnson, seconded by Jeff Rader and passed 7-0-0-0 to approve 1. BCBSGa's proposed administrative fee of \$40.50 PEPM which is unchanged from the current rate, and the approval of proposed Stop Loss insurance rate of \$72.50 PEPM. 2. The proposed Kaiser fully insured rates for actives & early retirees with an 8.2% increase over current rates for actives and early retirees. 3. The proposed Dental rates with a 7% increase over current rates. And Authorize the Chief Executive Officer to execute all necessary documents.*PEPM - per employee per month.

ADOPTED: MAR 28 2017
(DATE)
Kathie Gannon
PRESIDING OFFICER
DEKALB COUNTY BOARD OF
COMMISSIONERS

CERTIFIED: MAR 28 2017
(DATE)
Rebecca L. Gann
CLERK,
DEKALB COUNTY BOARD
OF COMMISSIONERS

FOR USE BY CHIEF EXECUTIVE OFFICER ONLY

APPROVED: APR 05 2017
(DATE)
WJ
CHIEF EXECUTIVE OFFICER
DEKALB COUNTY

VETOED: _____
(DATE)
CHIEF EXECUTIVE OFFICER
DEKALB COUNTY

VETO STATEMENT ATTACHED: _____

MINUTES:

FOR : Kathie Gannon, Steve Bradshaw, Gregory Adams, Nancy Jester, Larry Johnson, Mereda Davis Johnson, Jeff Rader

AGAINST : None

ABSTAIN : None

ABSENT : None

BOARD OF COMMISSIONERS

BUSINESS AGENDA / MINUTES

MEETING DATE: March 28, 2017

HEARING TYPE

Preliminary

ACTION TYPE

Resolution

SUBJECT: Support for Replacement of Mercer University Drive Bridge Over North Fork Peachtree Creek Commission Districts - 1 and 7

DEPARTMENT: Public Works - Transportation

PUBLIC HEARING: YES NO

ATTACHMENTS: YES No

INFORMATION: David Pelton

CONTACT:

PAGES:

PHONE NUMBER: 770-492-5206

PURPOSE:

To consider supporting the Georgia Department of Transportation proposal to replace the Mercer University Drive bridge over North Fork Peachtree Creek, with the understanding that DeKalb County will provide half of the right-of-way cost.

NEED/IMPACT:

This bridge is in poor condition and in need of replacement. This is identified as a need in both the Comprehensive Transportation Plan and in last year's draft SPLOST project list. The Georgia Department of Transportation is proposing to provide preliminary engineering, construction and half of the right-of-way costs. If they proceed, they expect DeKalb County to provide the other half of the right-of-way cost.

FISCAL IMPACT:

There is no set budget for the project at this time, but bridge replacements typically involve limited right-of-way. It is anticipated that there will be sufficient funds in an existing HOST bridge safety account to cover the required match. Additional approval will be sought from the Board of Commissioners when more detailed costs are known.

RECOMMENDATION:

To support the Georgia Department of Transportation proposal to replace the Mercer University Drive bridge over North Fork Peachtree Creek, with the understanding that DeKalb County will provide half of the right-of-way cost.

FOR USE BY COMMISSION OFFICE/CLERK ONLY

ACTION : 2017-03-28 ItemH2

MOTION was made by Nancy Jester, seconded by Gregory Adams and passed 7-0-0-0 to approve substitute submitted from the floor to support the Georgia Department of Transportation proposal to replace the Mercer University Drive bridge over North Fork Peachtree Creek, with the understanding that DeKalb County will provide half of the right-of-way cost.

ADOPTED: MAR 28 2017
(DATE)

Kathie Gannon
PRESIDING OFFICER
DEKALB COUNTY BOARD OF
COMMISSIONERS

CERTIFIED: MAR 28 2017
(DATE)

Barbara A. Gaud
CLERK,
DEKALB COUNTY BOARD
OF COMMISSIONERS

FOR USE BY CHIEF EXECUTIVE OFFICER ONLY

APPROVED: APR 05 2017
(DATE)

[Signature]
CHIEF EXECUTIVE OFFICER
DEKALB COUNTY

VETOED: _____
(DATE)

CHIEF EXECUTIVE OFFICER
DEKALB COUNTY

VETO STATEMENT ATTACHED: _____

MINUTES:

FOR : Kathie Gannon, Steve Bradshaw, Gregory Adams, Nancy Jester, Larry Johnson, Mereda Davis Johnson, Jeff Rader

AGAINST : None

ABSTAIN : None

ABSENT : None

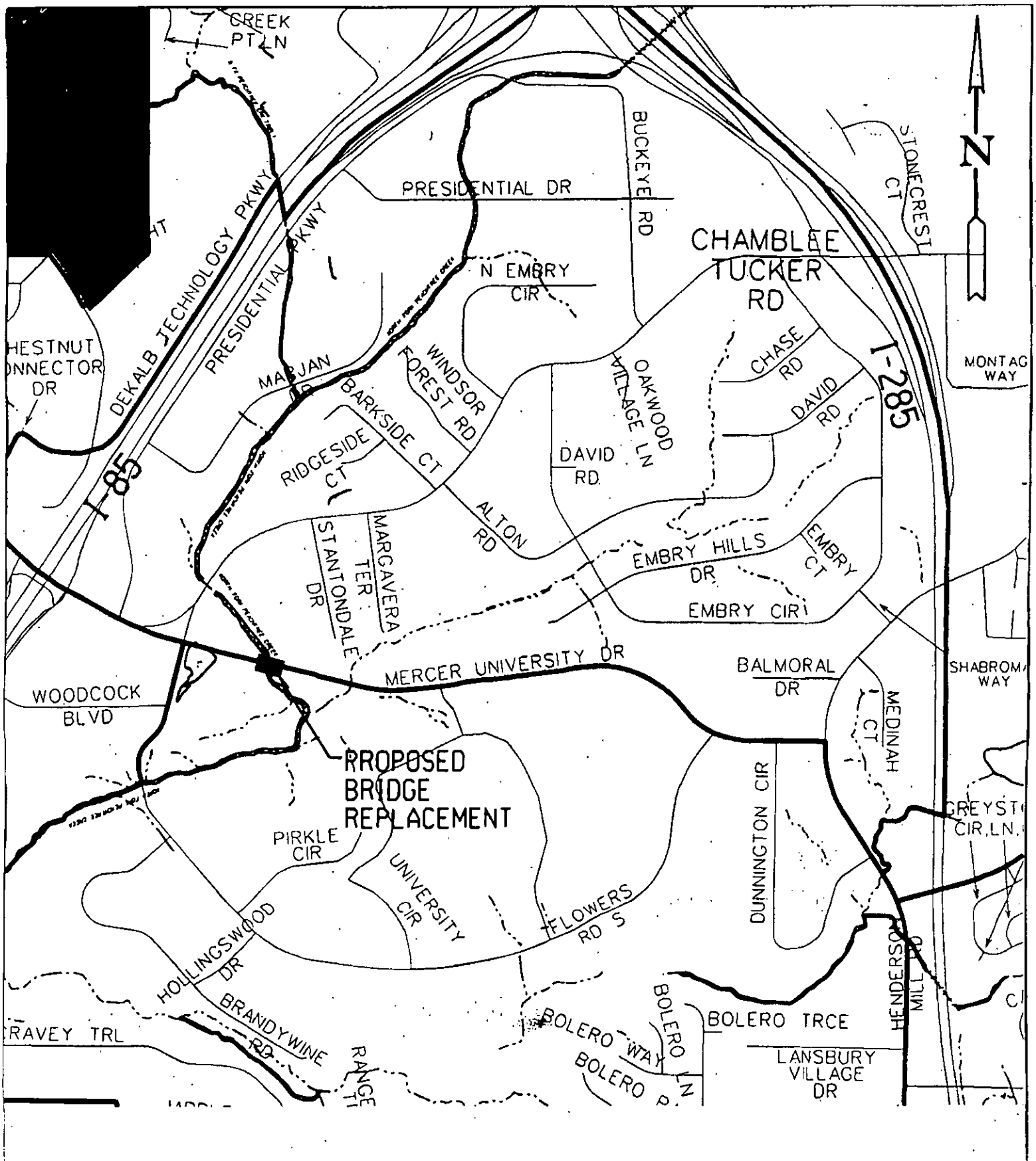

LOCATION MAP

DEKALB COUNTY
 TRANSPORTATION DIVISION
 1950 WEST EXCHANGE PLACE, 4th floor
 TUCKER, GA. 30084

DIS. 18	L.L. 266	ACCOUNT NUMBER	BOND/PROJECT NUMBER	SCALE	DATE	DRAWN	CHECKED	APPROVED	SE	DF
---------	----------	----------------	---------------------	-------	------	-------	---------	----------	----	----

DEKALB COUNTY

ITEM NO. H3

BOARD OF COMMISSIONERS

BUSINESS AGENDA / MINUTES

MEETING DATE: March 28, 2017

ACTION TYPE

HEARING TYPE
Preliminary

SUBJECT: Purchases - LB1. Roadway Bulk De-Icing Materials (Annual Contract with 2 Options to Renew)

DEPARTMENT: Purchasing and Contracting

PUBLIC HEARING: YES NO XX

ATTACHMENT: x YES No

PAGES: 3 8 1/2

INFORMATION CONTACT: Talisa R. Clark, CPPO
Interim Chief Procurement Officer

PHONE NUMBER: 105 8 5 RAM
(404) 687-2797

PURPOSE:

To consider award for purchases as attached.

NEED/IMPACT:

To provide for items and service to carry on the operation of the County. Approval will contribute to the efficient operation of the County by providing for needs of various departments.

RECOMMENDATION(S):

See end of each subject on attached. Unless otherwise noted, the recommended firm is low bidder as well as having met specifications

FOR USE BY COMMISSION OFFICE/CLERK ONLY

ACTION : 2017-03-28 ItemH3 LB1

MOTION was made by Gregory Adams, seconded by Nancy Jester and passed 7-0-0-0 to approve the Annual Contract with 2 Options to Renew for Roadway Bulk De-Icing Materials, for use by Public Works - Roads and Drainage (R&D), Recreation, Parks and Cultural Affairs (RPCA) and the Department of Watershed Management (DWM), with the total amount not to exceed \$214,649.70.

Items H3 and H4 were heard together.

ADOPTED: MAR 28 2017
(DATE)

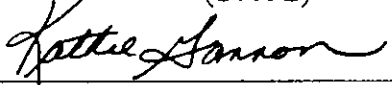
PRESIDING OFFICER
DEKALB COUNTY BOARD OF
COMMISSIONERS

CERTIFIED: MAR 28 2017
(DATE)

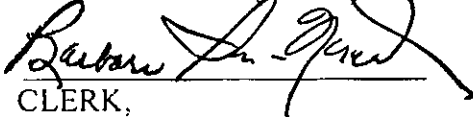
CLERK,
DEKALB COUNTY BOARD
OF COMMISSIONERS

FOR USE BY CHIEF EXECUTIVE OFFICER ONLY

APPROVED: APR 05 2017
(DATE)

CHIEF EXECUTIVE OFFICER
DEKALB COUNTY

VETOED: _____
(DATE)

CHIEF EXECUTIVE OFFICER
DEKALB COUNTY

VETO STATEMENT ATTACHED: _____

MINUTES:

- FOR : Kathie Gannon, Steve Bradshaw, Gregory Adams, Nancy Jester, Larry Johnson, Mereda Davis Johnson, Jeff Rader
- AGAINST : None
- ABSTAIN : None
- ABSENT : None

LOW BIDDER

LBI. Roadway Bulk De-Icing Materials (Annual Contract with 2 Options to Renew): Invitation No. 16-100749 for use by Public Works - Roads and Drainage (R&D), Recreation, Parks and Cultural Affairs (RPCA) and the Department of Watershed Management (DWM). Consists of the purchase of de-icing materials to make the sand/salt mixture used to maintain the County's roadways, parking lots, and sidewalks. Four (4) bids were received. Recommend award to the lowest responsive and responsible bidders:

Item No. 1

F.M. Shelton, Inc. 1434 Ralph D. Abernathy Boulevard SW, Unit 1, Atlanta, GA 30310

Note: LSBE-MSA Firm

Estimated Amount: \$91,529.70

Item No. 2

Compress Minerals, 9900 W 109th Street, Suite 100, Overland Park, KS 66210

Estimated Amount: \$123,120.00

Total Amount Not To Exceed: \$214,649.70

Notes:

- | | |
|------------------------------|---|
| 1. Commission District(s): | All |
| 2. Contract Effective Date: | Date of Award |
| 3. Contract Expiration Date: | 1 year term with 2 options to renew |
| 4. Funding: | Stormwater Management – Operating – R&D
General - Operating Supplies – RPCA
General - Operating – DWM |
| 5. Additional Bidders: | |

Morton Salt
123 North Wacker Drive
Chicago, IL 60606

Compass Minerals
9900 West 109th Street, Suite 100
Overland Park, KS 66210

DEKALB COUNTY

ITEM NO. H4

HEARING TYPE
Preliminary

BOARD OF COMMISSIONERS
BUSINESS AGENDA / MINUTES
MEETING DATE: March 28, 2017

ACTION TYPE

SUBJECT: Purchases - LB2. Silt Fencing, Sandbags, Straw and Mulch (Annual Contract with 2 Options to Renew)

DEPARTMENT: Purchasing and Contracting

PUBLIC HEARING: YES NO XX

ATTACHMENT: YES No
PAGES:

INFORMATION CONTACT: Talisa R. Clark, CPPO
Interim Chief Procurement Officer
PHONE NUMBER: (404) 687-2797

PURPOSE:

To consider award for purchases as attached.

NEED/IMPACT:

To provide for items and service to carry on the operation of the County. Approval will contribute to the efficient operation of the County by providing for needs of various departments.



RECOMMENDATION(S):

See end of each subject on attached. Unless otherwise noted, the recommended firm is low bidder as well as having met specifications

FOR USE BY COMMISSION OFFICE/CLERK ONLY

ACTION : 2017-03-28 ItemH4 LB2

MOTION was made by Gregory Adams, seconded by Nancy Jester and passed 7-0-0-0 to approve the Annual Contract with 2 Options to Renew, for Silt Fencing, Sandbags, Straw and Mulch, for use by the Department of Watershed Management (DWM), Public Works - Roads & Drainage (R&D) and Sanitation, and Recreation, Parks, and Cultural Affairs (RCPA), with an amount not to exceed \$275,950.00.

Items H3 and H4 were heard together.

ADOPTED: MAR 28 2017
(DATE)

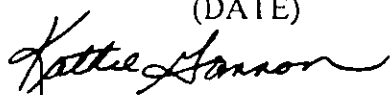
PRESIDING OFFICER
DEKALB COUNTY BOARD OF
COMMISSIONERS

CERTIFIED: MAR 28 2017
(DATE)

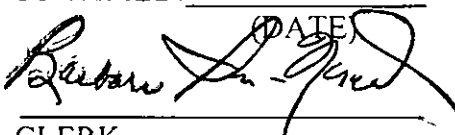
CLERK,
DEKALB COUNTY BOARD
OF COMMISSIONERS

FOR USE BY CHIEF EXECUTIVE OFFICER ONLY

APPROVED: APR 5 2017
(DATE)

CHIEF EXECUTIVE OFFICER
DEKALB COUNTY

VETOED: _____
(DATE)

CHIEF EXECUTIVE OFFICER
DEKALB COUNTY

VETO STATEMENT ATTACHED: _____

MINUTES:

FOR : Kathie Gannon, Steve Bradshaw, Gregory Adams, Nancy Jester, Larry Johnson, Mereda Davis Johnson, Jeff Rader

AGAINST : None

ABSTAIN : None

ABSENT : None

LOW BIDDER

LB2. Silt Fencing, Sandbags, Straw and Mulch (Annual Contract with 2 Options to Renew): Invitation No. 16-100756 for use by the Department of Watershed Management (DWM), Public Works – Roads & Drainage (R&D) and Sanitation, and Recreation, Parks, and Cultural Affairs (RPCA). Consists of the provision and installation of silt fencing, sandbags, straw and mulch for erosion control and landscaping. One (1) bid was received. Recommend award to the only bidder who is responsive and responsible:

PF Holding and Investment LLC, 1614 Rice Road, Lithonia, GA 30058

Amount Not To Exceed: \$275,950.00

Notes:

- | | |
|---------------------------------------|--|
| 1. Commission District(s): | All |
| 2. LSBE-DeKalb Participation: | 30% |
| 3. Contract Effective Date: | Date of Award |
| 4. Contract Expiration Date: | 1 year term with 2 options to renew |
| 5. Amount Spent on Previous Contract: | \$127,278.30 |
| 6. Funding: | General - Operating (DWM) & (Sanitation)
Stormwater Administration (R&D)
Operating - Maintenance & Repair (RPCA) |

DEKALB COUNTY

ITEM NO. H5

BOARD OF COMMISSIONERS

BUSINESS AGENDA / MINUTES

MEETING DATE: March 28, 2017

HEARING TYPE
Preliminary

ACTION TYPE

SUBJECT: Purchases - LB3. Glenwood Sidewalks Improvements, PI0002415/0010636 (18 months)

DEPARTMENT: Purchasing and Contracting

PUBLIC HEARING: YES NO XX

ATTACHMENT: x YES No
VIDS # 8 RAM
PAGES:

INFORMATION CONTACT: Talisa R. Clark, CPPO
Interim Chief Procurement Officer
PHONE NUMBER: (404) 687-2797

PURPOSE:

To consider award for purchases as attached.

NEED/IMPACT:

To provide for items and service to carry on the operation of the County. Approval will contribute to the efficient operation of the County by providing for needs of various departments.

MAR 30 2017

RECOMMENDATION(S):

See end of each subject on attached. Unless otherwise noted, the recommended firm is low bidder as well as having met specifications

FOR USE BY COMMISSION OFFICE/CLERK ONLY

ACTION : 2017-03-28 ItemH5 LB3

MOTION was made by Larry Johnson, seconded by Gregory Adams and passed 7-0-0-0 to approve PI0002415/0010636 (18 months), Glenwood Sidewalks Improvements consisting of constructing a sidewalk along both sides of Glenwood Road from east of Candler Road/SR 155 to Columbia Drive, for use by Public Works- Transportation.

ADOPTED: MAR 28 2017
(DATE)

Kathie Gannon
PRESIDING OFFICER
DEKALB COUNTY BOARD OF
COMMISSIONERS

CERTIFIED: MAR 28 2017
(DATE)

Robert A. Grier
CLERK,
DEKALB COUNTY BOARD
OF COMMISSIONERS

FOR USE BY CHIEF EXECUTIVE OFFICER ONLY

APPROVED: APR 05 2017
(DATE)

[Signature]
CHIEF EXECUTIVE OFFICER
DEKALB COUNTY

VETOED: _____
(DATE)

CHIEF EXECUTIVE OFFICER
DEKALB COUNTY

VETO STATEMENT ATTACHED: _____

MINUTES:

FOR : Kathie Gannon, Steve Bradshaw, Gregory Adams, Nancy Jester, Larry Johnson, Mereda Davis Johnson, Jeff Rader

AGAINST : None

ABSTAIN : None

ABSENT : None

LOW BIDDER

PURCHASING AND CONTRACTING DEPARTMENT

H5

LB3. Glenwood Sidewalks Improvements, PI0002415/0010636 (18 months): Invitation No. 16-100775 for use by Public Works - Transportation. Consists of constructing a sidewalk along both sides of Glenwood Road from east of Candler Road/SR 155 to Columbia Drive. Nine (9) bids were received. Recommend award to the lowest, responsive and responsible bidder:

BRTU Construction, Inc., 6105 Lee's Mill Road, Forest Park, GA 30297

Amount Not To Exceed: \$4,406,225.08

and authorize the Chief Executive Office to execute the contract and all associated documents.

Notes:

- | | |
|------------------------------|--|
| 1. Commission District(s): | 3 and 7 |
| 2. DBE Participation: | 100% |
| 3. Contract Effective Date: | Date of Award |
| 4. Contract Expiration Date: | December 31, 2018 |
| 5. Funding: | GDOT and HOST (Homestead Option Sales Tax)
(Transportation) |
| 6. Additional Bidders: | |

Precision 2000, Inc.
2215 Lawson Way
Atlanta, GA 30341

CMEX, Inc
6555 McDonough Drive
Norcross, GA 30093

Tople Construction & Engineering, Inc.
792 Donald Lee Hollowell Parkway NW
Atlanta, GA 30318

Lewallen Construction Co.
151 Bells Ferry Lane
Marietta, GA 30066

Pittman Construction Co.
1487 Farmer Road
Conyers, GA 30012

Ohmshiv Construction, LLC
1805 Herrington Road, Bldg #3, Suite E
Lawrenceville, GA 30043

Astra Group, Inc.
300 Churchill Court
Woodstock, GA 30188

SD&C, Inc.
4473 Covington Highway
Decatur, GA 30035

DEKALB COUNTY

ITEM NO. H6

BOARD OF COMMISSIONERS

BUSINESS AGENDA / MINUTES

MEETING DATE: March 28, 2017

HEARING TYPE
Preliminary

ACTION TYPE

SUBJECT: Purchases - LB4. Installation of Data, Voice and Multi-Media Cabling (Annual Contract with 2 Options to Renew)

DEPARTMENT: Purchasing and Contracting

PUBLIC HEARING: YES NO XX

ATTACHMENT: YES No
PAGES:

INFORMATION CONTACT: Talisa R. Clark, CPPO
Interim Chief Procurement Officer
PHONE NUMBER: (404) 687-2797

PURPOSE:

To consider award for purchases as attached.

NEED/IMPACT:

To provide for items and service to carry on the operation of the County. Approval will contribute to the efficient operation of the County by providing for needs of various departments.

RECOMMENDATION(S):

See end of each subject on attached. Unless otherwise noted, the recommended firm is low bidder as well as having met specifications

FOR USE BY COMMISSION OFFICE/CLERK ONLY

ACTION : 2017-03-28 ItemH6 LB4

MOTION was made by Steve Bradshaw, seconded by Mereda Davis Johnson and passed 7-0-0-0 to defer to the next meeting until April 11, 2017, the Annual Contract with 2 Options to Renew, for the installation of Data, Voice and Multi-Media Cabling, for use by the Department of Innovation & Technology (IT), with an amount not to exceed \$500,000.00.

ADOPTED: MAR 28 2017
(DATE)

Kathie Gannon
PRESIDING OFFICER
DEKALB COUNTY BOARD OF
COMMISSIONERS

CERTIFIED: MAR 28 2017
(DATE)

Barbara L. Grier
CLERK,
DEKALB COUNTY BOARD
OF COMMISSIONERS

FOR USE BY CHIEF EXECUTIVE OFFICER ONLY

APPROVED: APR 05 2017
(DATE)

[Signature]
CHIEF EXECUTIVE OFFICER
DEKALB COUNTY

VETOED: _____
(DATE)

CHIEF EXECUTIVE OFFICER
DEKALB COUNTY

VETO STATEMENT ATTACHED: _____

MINUTES:

FOR : Kathie Gannon, Steve Bradshaw, Gregory Adams, Nancy Jester, Larry Johnson, Mereda Davis Johnson, Jeff Rader

AGAINST : None

ABSTAIN : None

ABSENT : None

LOW BIDDER

LB4. Installation of Data, Voice and Multi-Media Cabling (Annual Contract with 2 Options to Renew): Invitation No. 16-100800 for use by the Department of Innovation & Technology (IT). Consists of the installation of data, voice and multi-media cabling in the County owned facilities. Four (4) bids were received. Recommend award to the lowest, responsive and responsible bidder:

GC&E Systems Group, Inc., 5835 Peachtree Corners, East, Suite A, Norcross, GA 30092

Amount Not To Exceed: \$500,000.00

Notes:

- | | |
|---------------------------------------|-------------------------------------|
| 1. Commission District(s): | 20% |
| 3. Contract Effective Date: | 04/01/17 |
| 4. Contract Expiration Date: | 1 year term with 2 options to renew |
| 5. Amount Spent on Previous Contract: | \$893,441.24 |
| 6. Funding: | General – Operating (IT) |
| 7. Additional Bidders: | |

Pearlnet, LLC
2400 Herodain Way, Suite 390
Smyrna, GA 30080
(Non-Responsible)

Innovative Services, LLC
90 Firetower Road, Suite A
Covington, GA 30016
(Non-Responsible)

Customer 1st Communications
5555 Oakbrook Parkway
Suite 175, Building 100
Norcross, GA 30093

DEKALB COUNTY

ITEM NO. H7

BOARD OF COMMISSIONERS

BUSINESS AGENDA / MINUTES

MEETING DATE: March 28, 2017

HEARING TYPE
Preliminary

ACTION TYPE

SUBJECT: Purchases - REN1. Resilient Wedge Insert Valves (Annual Contract - 1st Renewal of 2 Options to Renew)

DEPARTMENT: Purchasing and Contracting

PUBLIC HEARING: YES NO XX

ATTACHMENT: x YES No
PAGES:

INFORMATION CONTACT: Talisa R. Clark, CPPO
Interim Chief Procurement Officer
PHONE NUMBER: (404) 687-2797

PURPOSE:

To consider award for purchases as attached.

NEED/IMPACT:

To provide for items and service to carry on the operation of the County. Approval will contribute to the efficient operation of the County by providing for needs of various departments.

RECOMMENDATION(S):

See end of each subject on attached. Unless otherwise noted, the recommended firm is low bidder as well as having met specifications

FOR USE BY COMMISSION OFFICE/CLERK ONLY

ACTION : 2017-03-28 ItemH7 REN1

MOTION was made by Gregory Adams, seconded by Nancy Jester and passed 7-0-0-0 to approve the Annual Contract - 1st Renewal of 2 Options to Renew, for Resilient Wedge Insert Valves, for use by the Department of Watershed Management (DWM), with an amount not to exceed \$647,632.80.

Items H7 thru H10 were heard together.

ADOPTED: MAR 28 2017
(DATE)

Kathie Gannon
PRESIDING OFFICER
DEKALB COUNTY BOARD OF
COMMISSIONERS

CERTIFIED: MAR 28 2017
(DATE)

Robert L. Grew
CLERK,
DEKALB COUNTY BOARD
OF COMMISSIONERS

FOR USE BY CHIEF EXECUTIVE OFFICER ONLY

APPROVED: APR 05 2017
(DATE)

[Signature]
CHIEF EXECUTIVE OFFICER
DEKALB COUNTY

VETOED: _____
(DATE)

CHIEF EXECUTIVE OFFICER
DEKALB COUNTY

VETO STATEMENT ATTACHED: _____

MINUTES:

FOR : Kathie Gannon, Steve Bradshaw, Gregory Adams, Nancy Jester, Larry Johnson, Mereda Davis Johnson, Jeff Rader

AGAINST : None

ABSTAIN : None

ABSENT : None

RENEWAL

PURCHASING AND CONTRACTING DEPARTMENT

H7

REN1. Resilient Wedge Insert Valves (Annual Contract - 1st Renewal of 2 Options to Renew): Contract No. 1007234 for use by the Department of Watershed Management (DWM). Awarded by the BOC on March 22, 2016 for an amount not to exceed \$647,632.80. This contract consists of the purchase of resilient wedge insert valves for repair of water main lines. Recommend approval to exercise the 1st renewal option through March 31, 2018 for an amount not to exceed by \$647,632.80 with:

F.M. Shelton, Inc., 1434 Ralph D. Abernathy Blvd., SW, Unit 1, Atlanta, Georgia 30310

Amount Not To Exceed: \$647,632.80

Notes:

- | | |
|-------------------------------|---------------------------|
| 1. Commission District(s): | All |
| 2. LSBE-MSA Firm: | |
| 3. LSBE-DeKalb Participation: | 20% |
| 4. Contract Effective Date: | March 22, 2016 |
| 5. Contract Expiration Date: | March 31, 2017 |
| 6. Amount Spent to Date: | \$87,743.52 |
| 7. Funding: | General - Operating (DWM) |

DEKALB COUNTY

ITEM NO. H8

BOARD OF COMMISSIONERS

BUSINESS AGENDA / MINUTES

MEETING DATE: March 28, 2017

HEARING TYPE
Preliminary

ACTION TYPE

SUBJECT: Purchases - REN2. Annual Machine Shop Services (Annual Contract – 2nd Renewal of 2 Options to Renew)

DEPARTMENT: Purchasing and Contracting

PUBLIC HEARING: YES NO XX

ATTACHMENT: YES No
PAGES:

INFORMATION CONTACT: Talisa R. Clark, CPPO
Interim Chief Procurement Officer
PHONE NUMBER: (404) 687-2797

PURPOSE:

To consider award for purchases as attached.

NEED/IMPACT:

To provide for items and service to carry on the operation of the County. Approval will contribute to the efficient operation of the County by providing for needs of various departments.

[Handwritten signature]

RECOMMENDATION(S):

See end of each subject on attached. Unless otherwise noted, the recommended firm is low bidder as well as having met specifications

FOR USE BY COMMISSION OFFICE/CLERK ONLY

ACTION : 2017-03-28 ItemH8 REN2

MOTION was made by Gregory Adams, seconded by Nancy Jester and passed 7-0-0-0 to approve the Annual Contract - 2nd Renewal of 2 Options to Renew, for Annual Machine Shop Services, for use by the Department of Watershed Management (DWM), with an amount not to exceed \$2,000,000.00.

Items H7 thru H10 were heard together.

ADOPTED: MAR 28 2017
(DATE)

Kathie Gannon
PRESIDING OFFICER
DEKALB COUNTY BOARD OF
COMMISSIONERS

CERTIFIED: MAR 28 2017
(DATE)

Robert L. Grier
CLERK,
DEKALB COUNTY BOARD
OF COMMISSIONERS

FOR USE BY CHIEF EXECUTIVE OFFICER ONLY

APPROVED: APR 05 2017
(DATE)

MA
CHIEF EXECUTIVE OFFICER
DEKALB COUNTY

VETOED: _____
(DATE)

CHIEF EXECUTIVE OFFICER
DEKALB COUNTY

VETO STATEMENT ATTACHED: _____

MINUTES:

FOR : Kathie Gannon, Steve Bradshaw, Gregory Adams, Nancy Jester, Larry Johnson, Mereda Davis Johnson, Jeff Rader

AGAINST : None

ABSTAIN : None

ABSENT : None

RENEWAL

PURCHASING AND CONTRACTING DEPARTMENT

H8

REN2. Annual Machine Shop Services (Annual Contract – 2nd Renewal of 2 Options to Renew):
Contract No. 966901 for use by the Department of Watershed Management (DWM). Awarded by the BOC on April 28, 2015 for an amount not to exceed \$500,000.00. On April 28, 2016, the BOC approved the 1st renewal option for an amount not to exceed \$500,000.00. This contract consists of work on machinery parts. Recommend approval to exercise the 2nd renewal option through April 30, 2018 for an amount not to exceed by \$2,000,000.00 with:

Cole Technology, Inc., 3980 Martin Luther King Jr. Drive, Atlanta, GA 30336

Amount Not To Exceed: \$2,000,000.00

Notes:

- | | |
|------------------------------|--|
| 1. Commission District(s): | All |
| 2. Contract Effective Date: | April 28, 2015 |
| 3. Contract Expiration Date: | April 27, 2017 |
| 4. Amount Spent to Date: | \$1,000,000.00
\$478,993.52 – Initial
\$518,689.72 – 1 st Renewal |
| 5. Funding: | General – Operating (DWM) |

DEKALB COUNTY

ITEM NO. H9

BOARD OF COMMISSIONERS

BUSINESS AGENDA / MINUTES

MEETING DATE: March 28, 2017

ACTION TYPE

HEARING TYPE
Preliminary

SUBJECT: Purchases - REN3. Ready Mix Concrete (Annual Contract - 1st Renewal of 2 Options to Renew)

DEPARTMENT: Purchasing and Contracting

PUBLIC HEARING: YES NO XX

ATTACHMENT: x YES No

PAGES:

INFORMATION CONTACT: Talisa R. Clark, CPPO
Interim Chief Procurement Officer
PHONE NUMBER: (404) 687-2797

PURPOSE:

To consider award for purchases as attached.

NEED/IMPACT:

To provide for items and service to carry on the operation of the County. Approval will contribute to the efficient operation of the County by providing for needs of various departments.

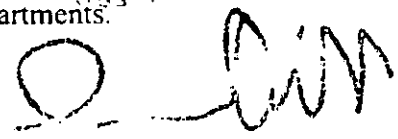

RECOMMENDATION(S):

See end of each subject on attached. Unless otherwise noted, the recommended firm is low bidder as well as having met specifications

FOR USE BY COMMISSION OFFICE/CLERK ONLY

ACTION : 2017-03-28 ItemH9 REN3

MOTION was made by Gregory Adams, seconded by Nancy Jester and passed 7-0-0-0 to approve the Annual Contract - 1st Renewal of 2 Options to Renew, for Ready Mix Concrete, for use by Public Works - Roads and Drainage (R&D), with the total amount not to exceed \$175,250.00.

Items H7 thru H10 were heard together.

ADOPTED: MAR 28 2017

(DATE)

Kathie Gannon

PRESIDING OFFICER
DEKALB COUNTY BOARD OF
COMMISSIONERS

CERTIFIED: MAR 28 2017

(DATE)

Richard L. Gann

CLERK,
DEKALB COUNTY BOARD
OF COMMISSIONERS

FOR USE BY CHIEF EXECUTIVE OFFICER ONLY

APPROVED: APR 05 2017

(DATE)

W. O. Q.

CHIEF EXECUTIVE OFFICER
DEKALB COUNTY

VETOED: _____

(DATE)

CHIEF EXECUTIVE OFFICER
DEKALB COUNTY

VETO STATEMENT ATTACHED: _____

MINUTES:

FOR : Kathie Gannon, Steve Bradshaw, Gregory Adams, Nancy Jester, Larry Johnson, Mereda Davis Johnson, Jeff Rader

AGAINST : None

ABSTAIN : None

ABSENT : None

RENEWAL

REN3. Ready Mix Concrete (Annual Contract - 1st Renewal of 2 Options to Renew): Contract No. 1009130 for use by Public Works – Roads and Drainage (R&D). Awarded by the BOC on March 22, 2016 for an amount not to exceed \$175,250.00. This contract consists of providing crushed granite stone for use in various applications. Recommend approval to exercise the 1st renewal option through March 21, 2018 for an amount not to exceed by \$175,250.00 with:

SiteMix, LLC, P.O. Box 459, Hampton, GA 30228

Total Amount Not To Exceed: \$175,250.00

Notes:

- | | |
|------------------------------|---|
| 1. Commission District(s): | All |
| 2. Contract Effective Date: | March 22, 2016 |
| 3. Contract Expiration Date: | March 21, 2017 |
| 4. Amount Spent to Date: | \$128,132.50 |
| 5. Funding: | Stormwater Management Operating - (R&D) |

DEKALB COUNTY

ITEM NO. H10

BOARD OF COMMISSIONERS

BUSINESS AGENDA / MINUTES

MEETING DATE: March 28, 2017

HEARING TYPE
Preliminary

ACTION TYPE

SUBJECT: Purchases - REN4. Steel Refuse Containers and Lids (Annual Contract – 2nd Renewal of 2 Options to Renew)

DEPARTMENT: Purchasing and Contracting

PUBLIC HEARING: YES NO XX

ATTACHMENT: YES No

PAGES: 3 PAM

INFORMATION CONTACT: Talisa R. Clark, CPPO
Interim Chief Procurement Officer

PHONE NUMBER: (404) 687-2797

PURPOSE:

To consider award for purchases as attached.

NEED/IMPACT:

To provide for items and service to carry on the operation of the County. Approval will contribute to the efficient operation of the County by providing for needs of various departments.



RECOMMENDATION(S):

See end of each subject on attached. Unless otherwise noted, the recommended firm is low bidder as well as having met specifications

FOR USE BY COMMISSION OFFICE/CLERK ONLY

ACTION : 2017-03-28 ItemH10 REN4

MOTION was made by Gregory Adams, seconded by Nancy Jester and passed 7-0-0-0 to approve the Annual Contract - 2nd Renewal of 2 Options To Renew, for Steel Refuse Containers and Lids, for use by Public Works - Sanitation, with an amount not to exceed \$395,000.00.

Items H7 thru H10 were heard together.

ADOPTED: MAR 28 2017
(DATE)

Kathie Gannon

PRESIDING OFFICER
DEKALB COUNTY BOARD OF
COMMISSIONERS

CERTIFIED: MAR 28 2017
(DATE)

Richard A. Gaud

CLERK,
DEKALB COUNTY BOARD
OF COMMISSIONERS

FOR USE BY CHIEF EXECUTIVE OFFICER ONLY

APPROVED: APR 05 2017
(DATE)

[Signature]

CHIEF EXECUTIVE OFFICER
DEKALB COUNTY

VETOED: _____
(DATE)

CHIEF EXECUTIVE OFFICER
DEKALB COUNTY

VETO STATEMENT ATTACHED: _____

MINUTES:

FOR : Kathie Gannon, Steve Bradshaw, Gregory Adams, Nancy Jester, Larry Johnson, Mereda Davis Johnson, Jeff Rader

AGAINST : None

ABSTAIN : None

ABSENT : None

RENEWAL

PURCHASING AND CONTRACTING DEPARTMENT

H10

REN4. Steel Refuse Containers and Lids (Annual Contract – 2nd Renewal of 2 Options to Renew): Contract Nos.: 961491 and 961498 for use by Public Works – Sanitation. Awarded by the BOC on March 10, 2015 for an amount not to exceed \$199,814.25. On January 12, 2016, the BOC approved the 1st renewal option for an amount not to exceed \$500,000.00. These contracts consist of providing steel bottom commercial containers in sizes 3, 4, 6 and 8 cubic yards. Sanitation has chosen not to renew Iron Container's contract due to their inability to meet the contract delivery schedule. Recommend approval to award lines items 1, 2, 5, 6, 9, 10, 11 and 12 and exercise the 2nd renewal option through March 31, 2018 for an amount not to exceed by \$395,000.00 with:

Draco Solutions, Inc., 4092 Suwanee Mill Drive, Buford, GA 30518

Amount Not To Exceed: \$395,000.00

Notes:

- | | |
|------------------------------|--|
| 1. Commission District(s): | All |
| 2. Contract Effective Date: | March 10, 2015 |
| 3. Contract Expiration Date: | March 31, 2017 |
| 4. Amount Spent to Date: | \$686,110.80
Initial - \$199,329.25
1 st Renewal - \$486,781.55 |
| 5. Funding: | Enterprise-Operating (Sanitation) |

DEKALB COUNTY

ITEM NO. H11

BOARD OF COMMISSIONERS

BUSINESS AGENDA / MINUTES

MEETING DATE: March 28, 2017

HEARING TYPE
Preliminary

ACTION TYPE

SUBJECT: Purchases - REN5. HVAC System for Animal Control (Annual Contract-1st Renewal of 2 Options to Renew)

DEPARTMENT: Purchasing and Contracting

PUBLIC HEARING: YES NO XX

ATTACHMENT: x YES No
PAGES: 5

INFORMATION CONTACT: Talisa R. Clark, CPPO
Interim Chief Procurement Officer
PHONE NUMBER: (404) 687-2797

PURPOSE:

To consider award for purchases as attached.

NEED/IMPACT:

To provide for items and service to carry on the operation of the County. Approval will contribute to the efficient operation of the County by providing for needs of various departments.

Handwritten signature and date: 3/28/17

RECOMMENDATION(S):

See end of each subject on attached. Unless otherwise noted, the recommended firm is low bidder as well as having met specifications

FOR USE BY COMMISSION OFFICE/CLERK ONLY

ACTION : 2017-03-28 ItemH11 RENS

MOTION was made by Steve Bradshaw, seconded by Mereda Davis Johnson and passed 7-0-0-0 to defer to the next meeting until April 11, 2017, the Annual Contract-1st Renewal of 2 Options to Renew, for HVAC System for Animal Control, for use by Police Services (PS) - Animal Services, with an amount not to exceed \$74,022.00.

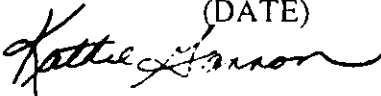
ADOPTED: MAR 28 2017
(DATE)

PRESIDING OFFICER
DEKALB COUNTY BOARD OF
COMMISSIONERS

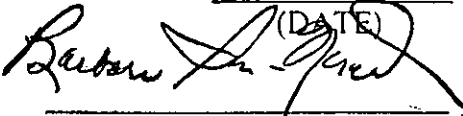
CERTIFIED: MAR 28 2017
(DATE)

CLERK,
DEKALB COUNTY BOARD
OF COMMISSIONERS

FOR USE BY CHIEF EXECUTIVE OFFICER ONLY

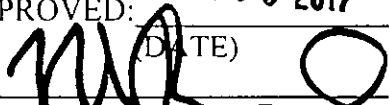
APPROVED: APR 05 2017
(DATE)

CHIEF EXECUTIVE OFFICER
DEKALB COUNTY

VETOED: _____
(DATE)

CHIEF EXECUTIVE OFFICER
DEKALB COUNTY

VETO STATEMENT ATTACHED: _____

MINUTES:

FOR : Kathie Gannon, Steve Bradshaw, Gregory Adams, Nancy Jester, Larry Johnson, Mereda Davis Johnson, Jeff Rader

AGAINST : None

ABSTAIN : None

ABSENT : None

RENEWAL

REN5. HVAC System for Animal Control (Annual Contract-1st Renewal of 2 Options to Renew):
Contract No. 1013132 for use by Police Services (PS) – Animal Services. Awarded on April 27, 2016 for an amount not to exceed \$74,022.00. This contract consists of the rental of an HVAC system. Recommend approval to exercise the 1st renewal option through April 30, 2018 for an amount not to exceed by \$74,022.00 with:

Spot Coolers, 3290 Green Pointe Pkwy., Suite 100, Norcross, GA 30092

Amount Not To Exceed: \$74,022.00

NOTES:

- | | |
|------------------------------|--------------------------|
| 1. Commission District(s): | All |
| 2. Contract Effective Date: | April 27, 2016 |
| 3. Contract Expiration Date: | April 26, 2017 |
| 4. Amount Spent to Date: | \$70,524.00 |
| 5. Funding: | General - Operating (PS) |

DEKALB COUNTY

ITEM NO. H12

BOARD OF COMMISSIONERS

BUSINESS AGENDA / MINUTES

MEETING DATE: March 28, 2017

HEARING TYPE
Preliminary

ACTION TYPE

SUBJECT: Purchases - CO1. Change Order No. 1 to Contract No. 991389 for Crane Services (Annual Contract with 2 Options to Renew)

DEPARTMENT: Purchasing and Contracting

PUBLIC HEARING: YES NO XX

ATTACHMENT: YES No
PAGES:

INFORMATION CONTACT: Talisa R. Clark, CPPO
Interim Chief Procurement Officer
PHONE NUMBER: (404) 687-2797

PURPOSE:

To consider award for purchases as attached.

NEED/IMPACT:

To provide for items and service to carry on the operation of the County. Approval will contribute to the efficient operation of the County by providing for needs of various departments.

RECOMMENDATION(S):

See end of each subject on attached. Unless otherwise noted, the recommended firm is low bidder as well as having met specifications

FOR USE BY COMMISSION OFFICE/CLERK ONLY

ACTION : 2017-03-28 ItemH12 CO1

MOTION was made by Gregory Adams, seconded by Jeff Rader and passed 7-0-0-0 to approve the Change Order No. 1 to the Annual Contract with 2 Options to Renew, for Crane Services, for use by the Department of Watershed Management (DWM).

ADOPTED: MAR 28 2017
(DATE)

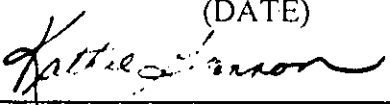

PRESIDING OFFICER
DEKALB COUNTY BOARD OF
COMMISSIONERS

CERTIFIED: MAR 28 2017
(DATE)

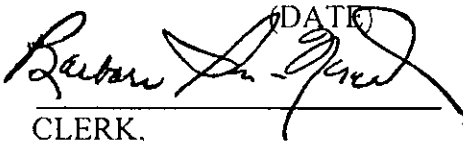

CLERK,
DEKALB COUNTY BOARD
OF COMMISSIONERS

FOR USE BY CHIEF EXECUTIVE OFFICER ONLY

APPROVED: APR 05 2017
(DATE)



CHIEF EXECUTIVE OFFICER
DEKALB COUNTY

VETOED: _____
(DATE)

CHIEF EXECUTIVE OFFICER
DEKALB COUNTY

VETO STATEMENT ATTACHED: _____

MINUTES:

FOR : Kathie Gannon, Steve Bradshaw, Gregory Adams, Nancy Jester, Larry Johnson, Mereda Davis Johnson, Jeff Rader

AGAINST : None

ABSTAIN : None

ABSENT : None

CHANGE ORDER

11/11/2011 10:11:11 AM

CO1. Change Order No. 1 to Contract No. 991389 for Crane Services (Annual Contract with 2 Options to Renew) for use by the Department of Watershed Management (DWM). Awarded by the BOC to AmQuip Crane Rental, LLC, on October 27, 2015 for an amount not to exceed \$250,000.00. On October 11, 2016, the BOC approved the 1st renewal of the contract for an amount not to exceed \$60,000.00. This contract consists of crane rental and operating services. In January 2017, Amquip Crane Rental, LLC, was acquired by Maxim Crane Works, LP. Recommend approval of Change Order No. 1 for consent to assignment of Contract No. 991389 and transfer the remaining contract term and funds to:

Maxim Crane Works, LP, 77 Winks Lane, Bensalem, PA 19020

Amount Not To Exceed: \$60,000.00

and authorize the Chief Executive Officer to execute the change order and all associated documents.

Notes:

- | | |
|------------------------------|---------------------------|
| 1. Commission District(s): | All |
| 2. Contract Effective Date: | October 27, 2015 |
| 3. Contract Expiration Date: | October 31, 2017 |
| 4. Amount Spent to Date: | \$60,000.00 |
| 5. Funding: | General – Operating (DWM) |

DEKALB COUNTY

ITEM NO. H13

BOARD OF COMMISSIONERS

BUSINESS AGENDA / MINUTES

MEETING DATE: March 28, 2017

HEARING TYPE
Preliminary

ACTION TYPE

SUBJECT: Purchases - CO2. Change Order No. 7 to Contract No. 10-902075 for Software Licenses, Implementation Services, Integration Services, and Training for Comprehensive Property Tax Billing and Collections System Upgrade (iasWorld) (Sole Source)

DEPARTMENT: Purchasing and Contracting

PUBLIC HEARING: YES NO XX

ATTACHMENT: YES No
PAGES:

INFORMATION CONTACT: Talisa R. Clark, CPPO
Interim Chief Procurement Officer
PHONE NUMBER: (404) 687-2797

PURPOSE:

To consider award for purchases as attached.

NEED/IMPACT:

To provide for items and service to carry on the operation of the County. Approval will contribute to the efficient operation of the County by providing for needs of various departments.

RECOMMENDATION(S):

See end of each subject on attached. Unless otherwise noted, the recommended firm is low bidder as well as having met specifications

FOR USE BY COMMISSION OFFICE/CLERK ONLY

ACTION : 2017-03-28 ItemH13 CO2

MOTION was made by Steve Bradshaw, seconded by Mereda Davis Johnson and passed 7-0-0-0 to defer to the next meeting until April 11, 2017, the Change Order No. 7, for Software Licenses, Implementation Services, Integration Services, and Training for Comprehensive Property Tax Billing and Collections System Upgrade (iasWorld) (Sole Source), for use by the Department of Innovation and Technology (IT).

ADOPTED: MAR 28 2017
(DATE)

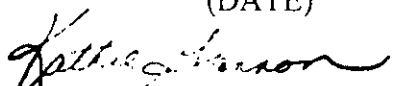

PRESIDING OFFICER
DEKALB COUNTY BOARD OF
COMMISSIONERS

CERTIFIED: MAR 28 2017
(DATE)

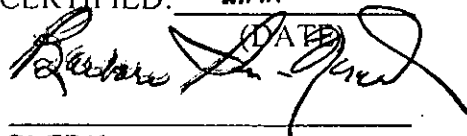

CLERK,
DEKALB COUNTY BOARD
OF COMMISSIONERS

FOR USE BY CHIEF EXECUTIVE OFFICER ONLY

APPROVED: APR 05 2017
(DATE)

CHIEF EXECUTIVE OFFICER
DEKALB COUNTY

VETOED: _____
(DATE)

CHIEF EXECUTIVE OFFICER
DEKALB COUNTY

VETO STATEMENT ATTACHED: _____

MINUTES:

FOR : Kathie Gannon, Steve Bradshaw, Gregory Adams, Nancy Jester, Larry Johnson, Mereda Davis Johnson, Jeff Rader

AGAINST : None

ABSTAIN : None

ABSENT : None

CHANGE ORDER

PURCHASING AND CONTRACTING DEPARTMENT

H13

CO2. Change Order No. 7 to Contract No. 10-902075 for Software Licenses, Implementation Services, Integration Services, and Training for Comprehensive Property Tax Billing and Collections System Upgrade (iasWorld) (Sole Source): for use by the Department of Innovation and Technology (IT). Awarded by the BOC on August 10, 2010 for an amount not to exceed \$2,712,500.00. Change Order No. 1 was approved on October 27, 2010 to modify the contract to include the option to purchase additional software. Change Order No. 2 was approved on October 25, 2011 to modify the contract to include the option to purchase additional software upgrades and implementation services. Change Order No. 3 was approved by the BOC on October 25, 2011 to purchase additional software upgrades and implementation services for an amount not to exceed \$1,801,630.00 and extend the contract term to April 30, 2014. Change Order No. 4 was approved by the BOC on May 13, 2014 to increase the contract amount not to exceed \$106,000.00 for the County Property Tax Billing and Collections System and extend the contract term to April 30, 2015. Change Order No. 5 was approved by the BOC on March 24, 2015 to increase the contract amount not to exceed \$50,000.00 and extend the contract term to April 30, 2016. Change Order No. 6 was approved by the BOC on March 22, 2016 to increase the contract amount not to exceed \$50,000.00 and extend the contract term to April 30, 2017. This contract consists of Implementation Services, Integration Services, and Training for the upgrade to iasWorld. Additional time is needed to develop and implement a new GISias World Interface, as well as provide training and Go Live support. Recommend approval of Change Order No. 7 to extend the contract term to April 30, 2018 with:

Tyler Technologies Inc., 4100 Miller-Valentine Court, Moraine, Ohio 45439

and authorize the Chief Executive Officer to execute the change order and all associated documents.

Notes:

- | | |
|------------------------------|--------------------------|
| 1. Commission District (s): | All |
| 2. LSBE Participation: | 19.99% |
| 3. Contract Effective Date: | August 10, 2010 |
| 4. Contract Expiration Date: | April 30, 2017 |
| 5. Amount Spent to Date: | \$4,623,655.00 |
| 6. Funding: | General – Operating (IT) |

DEKALB COUNTY

ITEM NO. H14

BOARD OF COMMISSIONERS

BUSINESS AGENDA / MINUTES

MEETING DATE: March 28, 2017

HEARING TYPE
Preliminary

ACTION TYPE

SUBJECT: Purchases - SS1. Hyland OnBase Software Licenses and Maintenance (Sole Source)

DEPARTMENT: Purchasing and Contracting

PUBLIC HEARING: YES NO XX

ATTACHMENT: YES No
PAGES: 1-10

INFORMATION CONTACT: Talisa R. Clark, CPPO
Interim Chief Procurement Officer
PHONE NUMBER: (404) 687-2797

PURPOSE:

To consider award for purchases as attached.

NEED/IMPACT:

To provide for items and service to carry on the operation of the County. Approval will contribute to the efficient operation of the County by providing for needs of various departments.

APR 10 2017
[Handwritten Signature]

RECOMMENDATION(S):

See end of each subject on attached. Unless otherwise noted, the recommended firm is low bidder as well as having met specifications

FOR USE BY COMMISSION OFFICE/CLERK ONLY

ACTION : 2017-03-28 ItemH14 SS1

MOTION was made by Nancy Jester, seconded by Larry Johnson and passed 7-0-0-0 to approve Hyland OnBase Software Licenses and Maintenance (Sole Source) for Information Technology (IT), for use by Police Services, Probate Court, Tax Commissioner and Property Appraiser, with an amount not to exceed \$400,000.00.

Items H14 and H15 were heard together.

ADOPTED: MAR 28 2017
(DATE)
Kathie Gannon
PRESIDING OFFICER
DEKALB COUNTY BOARD OF
COMMISSIONERS

CERTIFIED: MAR 28 2017
(DATE)
Barbara Davis Johnson
CLERK,
DEKALB COUNTY BOARD
OF COMMISSIONERS

FOR USE BY CHIEF EXECUTIVE OFFICER ONLY

APPROVED: APR 05 2017
(DATE)
W. O.
CHIEF EXECUTIVE OFFICER
DEKALB COUNTY

VETOED: _____
(DATE)
CHIEF EXECUTIVE OFFICER
DEKALB COUNTY

VETO STATEMENT ATTACHED: _____

MINUTES:

- FOR : Kathie Gannon, Steve Bradshaw, Gregory Adams, Nancy Jester, Larry Johnson, Mereda Davis Johnson, Jeff Rader
- AGAINST : None
- ABSTAIN : None
- ABSENT : None

SOLE SOURCE

PURCHASING AND CONTRACTING DEPARTMENT

H14

SS1. Hyland OnBase Software Licenses and Maintenance (Sole Source): for Information Technology (IT) for use by Police Services, Probate Court, Tax Commissioner and Property Appraiser. Consists of piggybacking off the competitively-let GSA contract for the OnBase Software Licenses for the electronic content management system. The software licenses are proprietary and the software publisher is the only source with access to the necessary information to provide maintenance and support of current systems. Recommend approval of the Sole Source for an amount not to exceed \$400,000.00 with:

Hyland Software, Inc., 28500 Clemens Road, Westlake, OH 44145

Amount Not To Exceed: \$400,000.00

Notes:

- | | |
|---------------------------------------|--------------------------|
| 1. Commission District(s): | All |
| 2. Contract Effective Date: | D |
| 3. Contract Expiration Date: | March 31, 2021 |
| 4. Amount Spent on Previous Contract: | \$151,071.88 |
| 5. Funding: | General - Operating (IT) |

DEKALB COUNTY

ITEM NO. H15

BOARD OF COMMISSIONERS

BUSINESS AGENDA / MINUTES

MEETING DATE: March 28, 2017

HEARING TYPE
Preliminary

ACTION TYPE

SUBJECT: Purchase - SS2. Software License, Oracle Planning, Budget and Reporting Cloud Services (Sole Source)s

DEPARTMENT: Purchasing and Contracting

PUBLIC HEARING: YES NO XX

ATTACHMENT: YES No

PAGES:

INFORMATION CONTACT: Talisa R. Clark, CPPO
Interim Chief Procurement Officer
PHONE NUMBER: (404) 687-2797

PURPOSE:

To consider award for purchases as attached.

NEED/IMPACT:

To provide for items and service to carry on the operation of the County. Approval will contribute to the efficient operation of the County by providing for needs of various departments.

MAR 28 2017

RECOMMENDATION(S):

See end of each subject on attached. Unless otherwise noted, the recommended firm is low bidder as well as having met specifications

FOR USE BY COMMISSION OFFICE/CLERK ONLY

ACTION : 2017-03-28 ItemH15 SS2

MOTION was made by Nancy Jester, seconded by Larry Johnson and passed 7-0-0-0 to approve Software License, Oracle Planning, Budget and Reporting Cloud Services (Sole Source), for use by the Office of Management and Budget (OMB), with an amount not to exceed \$163,800.00.

Items H14 and H15 were heard together.

ADOPTED: MAR 28 2017

(DATE)

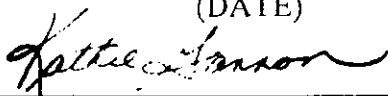

PRESIDING OFFICER
DEKALB COUNTY BOARD OF
COMMISSIONERS

CERTIFIED: MAR 28 2017

(DATE)



CLERK,
DEKALB COUNTY BOARD
OF COMMISSIONERS

FOR USE BY CHIEF EXECUTIVE OFFICER ONLY

APPROVED: APR 05 2017

(DATE)

CHIEF EXECUTIVE OFFICER
DEKALB COUNTY

VETOED: _____

(DATE)

CHIEF EXECUTIVE OFFICER
DEKALB COUNTY

VETO STATEMENT ATTACHED: _____

MINUTES:

FOR : Kathie Gannon, Steve Bradshaw, Gregory Adams, Nancy Jester, Larry Johnson, Mereda Davis Johnson, Jeff Rader

AGAINST : None

ABSTAIN : None

ABSENT : None

SOLE SOURCE

PURCHASING AND CONTRACTING DEPARTMENT

H15

SS2. Software License, Oracle Planning, Budget and Reporting Cloud Services (Sole Source): Contract No. 1000846 for use by the Office of Management and Budget (OMB). Consists of providing Oracle Cloud Services. The software licenses are proprietary and the software publisher is the only source with access to the necessary information to provide maintenance and support of current systems. Oracle America, Inc. is the sole provider of the Oracle Cloud Software Services. Recommend approval of the sole source for an amount not to exceed \$163,800.00 with:

Oracle America, Inc., One Glenlake Parkway NE, Suite 300, Atlanta, GA 30328

Amount Not To Exceed: \$163,800.00

Notes:

- | | |
|------------------------------|----------------------------------|
| 1. Commission District(s): | All |
| 2. Contract Effective Date: | January 1, 2016 |
| 3. Contract Expiration Date: | December 31, 2020 |
| 4. Funding: | General – Capital Projects (OMB) |

DEKALB COUNTY

ITEM NO. H16

BOARD OF COMMISSIONERS

BUSINESS AGENDA / MINUTES

MEETING DATE: March 28, 2017

HEARING TYPE
Preliminary

ACTION TYPE

SUBJECT: Purchases - RA1. PO# 1050535 for Transmission Water Main Repair Services at Henderson Mill Road and Caraway Drive (Ratification)

DEPARTMENT: Purchasing and Contracting

PUBLIC HEARING: YES NO XX

ATTACHMENT: x YES No
PAGES:

INFORMATION CONTACT: Talisa R. Clark, CPPO
Interim Chief Procurement Officer
PHONE NUMBER: (404) 687-2797

PURPOSE:

To consider award for purchases as attached.

NEED/IMPACT:

To provide for items and service to carry on the operation of the County. Approval will contribute to the efficient operation of the County by providing for needs of various departments.

RECOMMENDATION(S):

See end of each subject on attached. Unless otherwise noted, the recommended firm is low bidder as well as having met specifications

FOR USE BY COMMISSION OFFICE/CLERK ONLY

ACTION : 2017-03-28 ItemH16 RA1

MOTION was made by Gregory Adams, seconded by Nancy Jester and passed 7-0-0-0 to approve PO# 1050535 for Transmission Water Main Repair Services at Henderson Mill Road and Caraway Drive, for use by the Department of Watershed Management (DWM), with an amount not to exceed \$984,760.00.

ADOPTED: MAR 28 2017
(DATE)

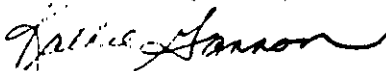

PRESIDING OFFICER
DEKALB COUNTY BOARD OF
COMMISSIONERS

CERTIFIED: MAR 28 2017
(DATE)



CLERK,
DEKALB COUNTY BOARD
OF COMMISSIONERS

FOR USE BY CHIEF EXECUTIVE OFFICER ONLY

APPROVED: APR 05 2017
(DATE)

CHIEF EXECUTIVE OFFICER
DEKALB COUNTY

VETOED: _____
(DATE)

CHIEF EXECUTIVE OFFICER
DEKALB COUNTY

VETO STATEMENT ATTACHED: _____

MINUTES:

FOR : Kathie Gannon, Steve Bradshaw, Gregory Adams, Nancy Jester, Larry Johnson, Mereda Davis Johnson, Jeff Rader

AGAINST : None

ABSTAIN : None

ABSENT : None

RATIFICATION

PURCHASING AND CONTRACTING DEPARTMENT

H16

RA1. PO# 1050535 for Transmission Water Main Repair Services at Henderson Mill Road and Caraway Drive (Ratification): for use by the Department of Watershed Management (DWM) Consists of an emergency repair for a broken 48" transmission water main on Henderson Mill Road, that was leaking excessively. This emergency repair was initiated to prevent the southern half of the County from being without water. Two (2) emergency quotes were received. The lowest, responsive and responsible quote was selected. Recommend approval of the ratification for an amount not to exceed \$984,760.00 with:

Ruby Collins, Inc., 4806 Wright Drive, Smyrna, GA. 30082

Amount Not To Exceed: \$984,760.00

Notes:

1. Commission District(s): 1
2. Funding: Renewal & Extension Funds (DWM)
3. Justification: There was an imminent threat to public health and safety, so immediate repairs are required to prevent water outage

DEKALB COUNTY

ITEM NO. H17

BOARD OF COMMISSIONERS

BUSINESS AGENDA / MINUTES

MEETING DATE: March 28, 2017

HEARING TYPE
Preliminary

ACTION TYPE

SUBJECT: Purchases - RFPI. Professional Services for the Implementation of Oracle Hyperion Planning and Budgeting Cloud Services for Public Sector

DEPARTMENT: Purchasing and Contracting

PUBLIC HEARING: YES NO XX

ATTACHMENT: x YES No
PAGES:

INFORMATION CONTACT: Talisa R. Clark, CPPO
Interim Chief Procurement Officer
PHONE NUMBER: (404) 687-2797

PURPOSE:

To consider award for purchases as attached.

NEED/IMPACT:

To provide for items and service to carry on the operation of the County. Approval will contribute to the efficient operation of the County by providing for needs of various departments.

[Handwritten signature]

RECOMMENDATION(S):

See end of each subject on attached. Unless otherwise noted, the recommended firm is low bidder as well as having met specifications

FOR USE BY COMMISSION OFFICE/CLERK ONLY

ACTION : 2017-03-28 ItemH17 RFP1

MOTION was made by Nancy Jester, seconded by Gregory Adams and passed 7-0-0-0 to approve Proposal No. 16-500417 for Professional Services for the Implementation of Oracle Hyperion Planning and Budgeting Cloud Services for Public Sector, for use by the Office of Management and Budget (OMB), with an amount not to exceed \$553,143.00.

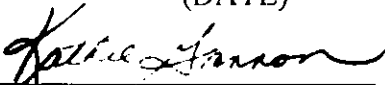
ADOPTED: MAR 28 2017
(DATE)

PRESIDING OFFICER
DEKALB COUNTY BOARD OF
COMMISSIONERS

CERTIFIED: MAR 28 2017
(DATE)

CLERK,
DEKALB COUNTY BOARD
OF COMMISSIONERS

FOR USE BY CHIEF EXECUTIVE OFFICER ONLY

APPROVED: APR 05 2017
(DATE)

CHIEF EXECUTIVE OFFICER
DEKALB COUNTY

VETOED: _____
(DATE)
CHIEF EXECUTIVE OFFICER
DEKALB COUNTY

VETO STATEMENT ATTACHED: _____

MINUTES:

FOR : Kathie Gannon, Steve Bradshaw, Gregory Adams, Nancy Jester, Larry Johnson, Mereda Davis Johnson, Jeff Rader

AGAINST : None

ABSTAIN : None

ABSENT : None

REQUEST
FOR
PROPOSAL

RFP1. Professional Services for the Implementation of Oracle Hyperion Planning and Budgeting Cloud Services for Public Sector: Request for Proposals No. 16-500417 for use by the Office of Management and Budget (OMB). Consists of providing services to streamline the budget preparation process and to enhance the County's ability to track and manage budgets in real-time, as well as integration with Oracle E-Business Suite (EBS) V12.1.3. Implementation will allow the County to pursue efficiencies in the current budget process through the ability to create and maintain multiple versions, leverage pre-built forms and workflows, better forecast of personnel costs, improve budget to actual reporting and analysis and expand five-year forecasting capabilities. Twelve (12) proposals were received. Recommend award to the highest scoring proposer:

Oracle America, Inc., One Glenlake Parkway NE, Suite 300, Atlanta, GA 30328

Amount Not To Exceed: \$553,143.00

and authorize the Chief Executive Officer to execute the contract and all associated documents.

Evaluation Committee Scores

<u>Firms</u>	<u>Scores</u>
Oracle America, Inc.	93
GNC Public Sector	92
Deloitte Solutions, LP	81
Sierra-Cedar	81
Ciber	78
AST Corp Tech	77
Innofin Solutions	71
F5 Tech Solutions	70
IBM	54

Non-Responsive Firms

Signum Group
Key Performance Ideas, Inc.
Performance Architects

After evaluation of technical and cost proposals, the recommendation is to award to the highest scoring proposer.

Notes:

- | | |
|------------------------------|----------------------------------|
| 1. Commission District(s): | All |
| 2. LSBE Participation: | 20% |
| 3. Contract Effective Date: | Date of Award |
| 4. Contract Expiration Date: | December 31, 2017 |
| 5. Funding: | General - Capital Projects (OMB) |

DEKALB COUNTY

ITEM NO. H18

BOARD OF COMMISSIONERS

HEARING TYPE
Preliminary

BUSINESS AGENDA / MINUTES

ACTION TYPE
Resolution

MEETING DATE: March 28, 2017

SUBJECT: 2017 Summer Food Services Program funded by the Georgia Department of Early Care and Learning.

DEPARTMENT: Recreation, Parks and Cultural Affairs

PUBLIC HEARING: YES NO

ATTACHMENT: YES No
PAGES:

INFORMATION CONTACT: Marvin F. Billups, Jr.
PHONE NUMBER: 404-371-4925

PURPOSE:

To authorize the Recreation, Parks and Cultural Affairs Department to apply to the State of Georgia's Department of Early Care Learning (DECAL) to request funding to implement the 2017 Summer Food Service Program (SFSP). The Department will provide breakfast and lunch to its Summer Day Campers and to approximately fifty (50) additional non-profit agencies throughout DeKalb County.

NEED/IMPACT:

During the school year, many children receive and reduced meals through the National School Lunch Program (NSLP). When school recesses for the summer, many children are at risk of hunger. According to KIDS COUNT 2015, 33% of children (55,573) in DeKalb County live in poverty; 511,677 of children enrolled in DeKalb County's School system received free or reduced meals as noted in the Georgia Department of Education, 2015 Free and Reduced Price Meal Eligibility Report.

RECOMMENDATION(S):

To authorize the Chief Executive Officer to execute all necessary documents with the State of Georgia's Department of Early Care and Learning (DECAL) to apply, receive and implement the 2017 Summer Food Service Program.

FOR USE BY COMMISSION OFFICE/CLERK ONLY

ACTION : 2017-03-28 ItemH18

MOTION was made by Larry Johnson, seconded by Gregory Adams and passed 7-0-0-0 to approve and authorize the Chief Executive Officer to execute all necessary documents with the State of Georgia's Department of Early Care and Learning (DECAL) to apply, receive and implement the 2017 Summer Food Service Program.

ADOPTED: MAR 28 2017
(DATE)

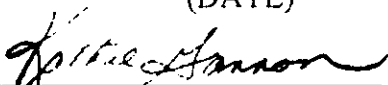
PRESIDING OFFICER
DEKALB COUNTY BOARD OF
COMMISSIONERS

CERTIFIED: MAR 28 2017
(DATE)

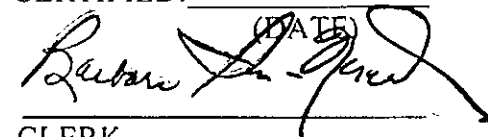
CLERK,
DEKALB COUNTY BOARD
OF COMMISSIONERS

FOR USE BY CHIEF EXECUTIVE OFFICER ONLY

APPROVED: APR 05 2017
(DATE)

CHIEF EXECUTIVE OFFICER
DEKALB COUNTY



VETOED: _____
(DATE)

CHIEF EXECUTIVE OFFICER
DEKALB COUNTY

VETO STATEMENT ATTACHED: _____

MINUTES:

FOR : Kathie Gannon, Steve Bradshaw, Gregory Adams, Nancy Jester, Larry Johnson, Mereda Davis Johnson, Jeff Rader

AGAINST : None

ABSTAIN : None

ABSENT : None

DEKALB COUNTY

ITEM NO. H19

BOARD OF COMMISSIONERS
BUSINESS AGENDA / MINUTES
MEETING DATE: March 28, 2017

HEARING TYPE
Preliminary

ACTION TYPE
Resolution

SUBJECT: Acceptance of \$5,000 from Peach State Health Plan to provide scholarship funds to support the afterschool and basketball programs.

DEPARTMENT: Recreation, Parks and Cultural Affairs

PUBLIC HEARING: YES NO

ATTACHMENT: YES No

INFORMATION CONTACT: Marvin F. Billups, Jr.

PAGES:

PHONE NUMBER: 404-371-4925

PURPOSE:

To authorize the Recreation, Parks and Cultural Affairs Department to receive funding from Peach State Health Plan for scholarships for youth enrolled in the afterschool and basketball programs.

NEED/IMPACT:

During the school year, the afterschool and basketball programs provide a safe haven for the children of working parents to ensure a structured afterschool care environment. The programs also promote physical fitness and wellness. Peach State wants to ensure that all children are provided these opportunities by providing scholarship funds.

RECOMMENDATION(S):

To authorize the Chief Executive Officer to execute all necessary documents with Peach State Health Plan to receive \$5,000 to provide scholarships to support the afterschool and basketball programs offered by the Recreation, Parks and Cultural Affairs Department.

FOR USE BY COMMISSION OFFICE/CLERK ONLY

ACTION : 2017-03-28 ItemH19

MOTION was made by Larry Johnson, seconded by Gregory Adams and passed 7-0-0-0 to approve and authorize the Chief Executive Officer to execute all necessary documents with the Peach State Health Plan to receive \$5,000 to provide scholarships to support the afterschool and basketball programs offered by the Recreation, Parks and Cultural Affairs Department.

ADOPTED: MAR 28 2017
(DATE)

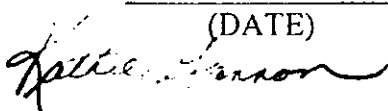

PRESIDING OFFICER
DEKALB COUNTY BOARD OF
COMMISSIONERS

CERTIFIED: MAR 28 2017
(DATE)

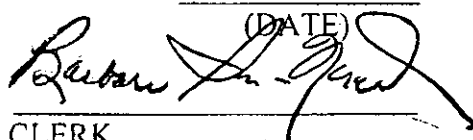

CLERK,
DEKALB COUNTY BOARD
OF COMMISSIONERS

FOR USE BY CHIEF EXECUTIVE OFFICER ONLY.

APPROVED: APR 05 2017
(DATE)

CHIEF EXECUTIVE OFFICER
DEKALB COUNTY

VETOED: _____
(DATE)

CHIEF EXECUTIVE OFFICER
DEKALB COUNTY

VETO STATEMENT ATTACHED: _____

MINUTES:

FOR : Kathie Gannon, Steve Bradshaw, Gregory Adams, Nancy Jester, Larry Johnson, Mereda Davis Johnson, Jeff Rader

AGAINST : None

ABSTAIN : None

ABSENT : None

DEKALB COUNTY

ITEM NO. 11

BOARD OF COMMISSIONERS

HEARING TYPE
Action

BUSINESS AGENDA / MINUTES

ACTION TYPE
Ordinance

MEETING DATE: March 28, 2017

SUBJECT: An Ordinance to Amend the County Code of Ordinances for Purposes of Regulating Hotels, Motels, and Extended-Stay Hotels

1105 2 8 894

DEPARTMENT: Board of Commissioners

PUBLIC HEARING: YES NO

ATTACHMENT: YES No

PAGES: 11

INFORMATION CONTACT: Commissioner Nancy Jester

PHONE NUMBER: 404-371-3052

Deferred 1/10/17, 2/14/17

1105 2 8 894

PURPOSE:

The purpose of this amendment is to ensure the continued availability of transient lodging within the County of DeKalb, the proper maintenance of hotels, motels, and extended-stay hotels, the protection of the health, safety and welfare of hotel, motel, and extended-stay hotel inhabitants.

NEED/IMPACT:

The current County Code of Ordinances insufficiently regulates hotels, motels, and extended stay hotels. The proposed amendment provides additional restrictions to further safeguard the customers and employees of transient lodging throughout the County.

RECOMMENDATION(S):

To Approve the Amendment to the County Code of Ordinance for Purposes of Regulating Hotels, Motels, and Extended-Stay Hotels.

FOR USE BY COMMISSION OFFICE/CLERK ONLY

ACTION : 2017-03-28 Item11

MOTION was made by Jeff Rader, seconded by Larry Johnson and passed 7-0-0-0 to defer for one month Until April 25, 2017, to approve the Amendment to the County Code of Ordinance for purposes of regulating Hotels, Motels, and Extended-Stay Hotels.

Items 11 and 12 were heard together.

ADOPTED: MAR 28 2017
(DATE)

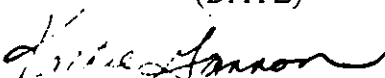
PRESIDING OFFICER
DEKALB COUNTY BOARD OF
COMMISSIONERS

CERTIFIED: MAR 28 2017
(DATE)

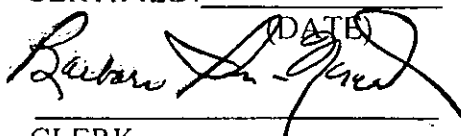
CLERK,
DEKALB COUNTY BOARD
OF COMMISSIONERS

FOR USE BY CHIEF EXECUTIVE OFFICER ONLY

APPROVED: APR 05 2017
(DATE)

CHIEF EXECUTIVE OFFICER
DEKALB COUNTY

VETOED: _____
(DATE)

CHIEF EXECUTIVE OFFICER
DEKALB COUNTY

VETO STATEMENT ATTACHED: _____

MINUTES:

FOR : Kathie Gannon, Steve Bradshaw, Gregory Adams, Nancy Jester, Larry Johnson, Mereda Davis Johnson, Jeff Rader

AGAINST : None

ABSTAIN : None

ABSENT : None

AN ORDINANCE TO AMEND CHAPTER 8 OF THE CODE OF DEKALB COUNTY, GEORGIA, TO ADD A NEW ARTICLE XII TO PROVIDE FOR THE CONTINUED AVAILABILITY OF TRANSIENT LODGING WITHIN THE COUNTY OF DEKALB, THE PROPERTY MAINTENANCE OF HOTELS, MOTELS, AND EXTENDED-STAY HOTELS, TO PROTECT THE HEALTH, SAFETY AND WELFARE OF HOTEL, MOTEL, AND EXTENDED-STAY HOTEL INHABITANTS, AND FOR OTHER PURPOSES.

WHEREAS, the Code of Ordinances of the County of DeKalb does not provide sufficient regulations to ensure the continued availability of transient lodging within the County of DeKalb, the proper maintenance of hotels, motels, and extended-stay hotels, the protection of the health, safety and welfare of hotel, motel, and extended-stay hotel inhabitants, and for other purposes as stated herein;

WHEREAS, the Board of Commissioner of DeKalb County have determined that it is in the best interest of the County to add a new Article XII to Chapter 8 of the Code of Ordinances of the County of DeKalb to provide for the continued availability of transient lodging within the DeKalb County, the proper maintenance of hotels, motels, and extended-stay hotels, for the protection of the health, safety and welfare of hotel, motel, and extended-stay hotel inhabitants, and for other purposes as stated herein; and

NOW THEREFORE, BE IT ORDAINED by the Governing Authority of DeKalb County, Georgia, and it is hereby ordained by the authority of same, that Chapter 8 of the Code of DeKalb County, as Revised 1988, is hereby amended to add a new Article XII as follows:

PART I. ENACTMENT

By amending Chapter 27 of the Code of DeKalb County as Revised 1988, to read as follows:

* * *

Sec. 8-500. – Purpose and definitions.

Purpose. The purpose of this ordinance is to ensure the continued availability of transient lodging within the County of DeKalb, proper maintenance of hotels,

motels, and extended-stay hotels and to protect the health, safety and welfare of hotel, motel, and extended-stay hotel inhabitants. The requirements of this ordinance apply to those who occupy, visit, patronize, frequent, operate, keep, conduct, or own a hotel, motel, or extended-stay hotel within the County of DeKalb regardless of the date of the hotel, motel, or extended-stay hotel's construction.

This ordinance is essential to the public's interest, safety, health, and welfare, and this ordinance shall be liberally construed to effectuate its purposes.

Definitions.

"Hotel" or "motel" shall mean any structure consisting of one or more buildings, with more than five dwelling units with provisions for transient living, sanitation, and sleeping, that is specifically constructed, kept, used, maintained, advertised, and held out to the public to be a place where temporary lodging of 15 days or less is offered for pay to persons, is not intended for long-term occupancy, and does not otherwise meet the definition of an extended-stay hotel as defined in this section.

"Extended-stay hotel" shall mean any structure consisting of one or more buildings, with more than five dwelling units with provisions for living, sanitation, and sleeping, that is specifically constructed, kept, used, maintained, advertised, and held out to the public to be a place where temporary residence is offered for pay to persons for non-transient extended-stays and/or stays longer than 30 days, regardless of the presence of rentals or leases for shorter periods of time.

"Vehicle" is any car, truck, trailer, motorcycle, or other machinery used for transporting people or goods and is normally required to be registered with the State in order to be legally operated or towed on a public roadway.

"Loitering" is defined in Section 28-2 of this Code.

"Patron" shall mean a person who pays a fee to the owner, operator, keeper or proprietor of the hotel, motel or extended-stay hotel.

"Guest" shall mean a person who is not a patron who is present on the premises of a hotel, motel or extended-stay hotel with the express permission of (a) a guest or patron of the hotel, motel or extended-stay hotel and (b) the owner, operator, keeper or proprietor of the hotel, motel or extended-stay hotel.

"Visitor" shall mean a person who is not a patron or guest who is on the premises of a hotel, motel or extended-stay hotel at the invitation of a patron or guest, but without the express permission of the owner, operator, keeper or proprietor of the hotel, motel or extended-stay hotel.

Sec. 8-501. - *Provisions applicable to hotels, motels, and extended-stay hotels.*

- (1) No hotel or motel located within the County shall allow any person to occupy such hotel or motel for more than fifteen (15) days in succession nor more than sixty (60) days during a one hundred eighty-day period. No guest residing for more than fifteen (15) days in succession shall move from one room to another without a two (2) day vacancy in between.
- (2) No extended-stay hotel located within the County shall allow any person to occupy such extended-stay hotel for more than thirty (30) days in succession during a one hundred eighty-day period unless otherwise permitted in this section.
- (3) Notwithstanding subsection (2) of this section, a stay in excess of the thirty (30) days in succession in a one hundred eighty-day period may occur in the following situations:
 - (a) Where there is a written contract or document between an extended-stay hotel and a business, corporation, firm or governmental agency to house employees or individuals on valid work orders for up to ninety (90) days in succession in a one hundred eighty-day period;
 - (b) Where there is a written contract between the extended-stay hotel and a governmental, charitable or insurance agency to house families in crisis who are receiving temporary housing assistance from said governmental, charitable or insurance agency for up to ninety (90) days in succession in a one hundred eighty-day period; or
 - (c) Where the Community Development Director authorizes in writing, after consultation with the Executive Assistant, a stay for an additional period of up to ninety (90) days to prevent patrons and their guests from becoming homeless. In the event that appropriate alternative housing can still not be obtained within ninety (90) days, this ninety day period may be extended in writing by the Community Development Director or the Executive Assistant; and
 - (d) The written contract, document, and authorization noted above shall be kept on file with the extended-stay hotel operator and must be available for inspection; and
 - (e) No patron or guest residing for more than thirty (30) days in succession shall move from one room to another without a two (2) day vacancy in between.

- (4) Notwithstanding subsection (1), (2) or (3) of this section, an owner, operator, keeper or proprietor of a hotel, motel, or extended-stay hotel may allow up to two bona-fide employees to reside on premises for any hotel, motel, or extended-stay hotel with up to one hundred fifty (150) rooms, and may allow up to three bona-fide employees to reside on premises for any hotel, motel, or extended-stay hotel over one hundred fifty (150) rooms.
- (5) No owner, operator, keeper or proprietor of a hotel, motel, or extended-stay hotel shall provide lodging at an hourly rate.

Sec. 8-502. – *Responsibilities, access, and registration requirements.*

- (1) Every owner, operator, keeper or proprietor of any hotel, motel, or extended-stay hotel shall, without delay, report violations of law to the DeKalb County Police Department that were either witnessed or made known to them by an employee, patron, guest, visitor or other person on the premises.
- (2) Every owner, operator, keeper or proprietor of any hotel, motel, or extended-stay hotel shall, at all times during which the premises accommodates patrons, guests, or visitors maintain on duty a responsible front desk clerk capable of assisting, communicating, and cooperating with the police or other law enforcement officials in maintaining the public health, welfare, and safety.
- (3) All information required to be procured and kept pursuant to this ordinance shall be provided to any federal, state, or local sworn law enforcement officer having the lawful power to arrest, upon demand of the officer and a representation by said officer that a reasonable suspicion exists that such information is relevant to a then-pending inquiry or investigation. Nothing in this requirement shall be construed as giving any such officer any greater right or license to enter a room or invade privacy than the officer shall otherwise possess as a matter of law, probable cause, constitutional law, statutory right, or warrant.
- (4) Every owner, operator, keeper or proprietor of any hotel, motel, or extended-stay hotel shall keep a record of all rental agreements between the hotel, motel, or extended-stay hotel and all patrons and their guests. For the purposes of this section, the term "record" shall mean the hotel, motel, or extended-stay hotel's electronic guest registration system which stores guest identifying information. In the event the hotel, motel, or extended-stay hotel does not have an electronic guest registration system, the hotel, motel, or extended-stay hotel shall record the guest, patron and their guest's information in a paper record or reservation book. The following information, at a minimum, must be recorded at the time of registration and maintained for a period of no less than one hundred eighty (180) days after the rental agreement's termination:

- (a) The full name, phone number, and home address of each patron and guest;
 - (b) The total number of occupants (patrons and guests) registered in each room;
 - (c) The room number assigned to each patron and guest;
 - (d) The day, month, year and time of arrival of each patron and guest;
 - (e) The day, month, year each patron and each guest is scheduled to depart;
 - (f) The rate charged and amount collected for rental of the room;
 - (g) The method of payment for each room; and
 - (h) The make, model, color, license plate number, and license plate state of the patron and guest's vehicle if the vehicle will be parked on the premises.
- (5) Every owner, operator, keeper or proprietor of any hotel, motel, or extended-stay hotel shall require each patron to provide proper identification prior to renting a room. Proper identification is defined as a current and valid government issued photo identification card such as a driver's license, military identification card, state identification card, or passport. A record and a photocopy of the provided identification shall be kept on file for the duration of the occupancy and for one hundred eighty (180) days thereafter.
- (6) No person shall procure or provide lodging in any hotel, motel, or extended-stay hotel, or any services therefrom, through misrepresentation or production of false identification, or identification which misrepresents the identity of the person procuring or sharing in such lodging or service.

Sec. 8-503. Vehicles, Parking, and Registration.

- (1) All patrons and guests who wish to park a vehicle on hotel premises must register said vehicle with the hotel operator upon initial registration, during any future re-registration, or at any time after registration when they begin parking a vehicle on hotel premises. Hotel operators must record the vehicle's information in accordance with Section 8-502.
- (2) Every owner, operator, keeper or proprietor of a hotel, motel, and extended-stay hotel must provide patrons and guests registering a vehicle with a standardized placard that must at all times be hung from the vehicle's rear view mirror, placed on the vehicle's front dash, or affixed to the vehicle in a way that can be easily seen. At a minimum, the placard will contain the

following information: hotel, motel, and extended-stay hotel name, vehicle registration number and state, and date of check-out. Any hotel, motel, or extended-stay hotel with gated and controlled access parking accessible only to employees and registered guests are exempt from this subsection (2).

- (3) All vehicles must be parked in designated parking spaces. All vehicles must be parked nose-in (backed in parking is not permitted) such that the vehicle's rear license plate is visible. This section does not apply to oversized vehicles or trailers. Every owner, operator, keeper or proprietor of a hotel, motel and extended-stay motel must provide patrons and guests who have registered oversized vehicles or trailers a separate designated parking area for their vehicles.
- (4) All handicap parking must be in compliance with State and local laws.
- (5) All vehicles parked on any hotel's premises must be in good working order.
- (6) Vehicle maintenance in hotel parking lots is prohibited.

Sec. 8-504. – Room requirements, equipment and services.

- (1) Every operator, owner, keeper, or proprietor of any hotel, motel, or extended-stay hotel shall keep and maintain in each and every rental unit, a telephone equipped to place a direct call to 911.
- (2) No operator, owner, keeper or proprietor of any hotel, motel, or extended-stay hotel shall rent or provide a room for any number of persons greater than the sleeping accommodations provided within the particular rental unit or temporary sleeping accommodations provided by the hotel, motel, or extended-stay hotel.
- (3) No operator, owner, keeper, or proprietor, patron, visitor or guest of any hotel, motel, or extended-stay hotel shall be allowed to congregate within any room or single rental unit a number of persons which is greater than two (2) times the number of persons for whom sleeping accommodations are provided within the single room or rental unit.
- (4) All extended-stay hotels must have enclosed, heated and air conditioned laundry space containing at least three clothes washers and three clothes dryers for guests. Such clothes washers and clothes dryers shall be in good working order.

- (5) Daily maid service shall be included within the standard room rate of any hotel or motel. Maid service shall be provided no less than two (2) times per week for each occupied guest room as part of the standard room rate at any extended-stay hotel when there exists a rental agreement of seven (7) days or longer.
- (6) No occupational tax certificate shall be issued for conduct of business from a guest room of a hotel, motel, or extended-stay hotel, and no home occupation shall be conducted from such room.
- (7) Each guest room of a hotel, motel, or extended-stay hotel shall be equipped with a sprinkler system and hard wired smoke detector approved by the fire marshal.

Sec. 8-505. – Common area requirements and parking illumination.

- (1) Exterior doors (other than lobby doors) shall be locked between the hours of 9:00 pm and 6:00 am and shall be equipped with an alarm or other device that will alert hotel, motel or extended-stay hotel security or other employees he door has been opened.
- (2) The open parking area and all areas surrounding any building or proposed building being a hotel, motel, or extended-stay hotel shall have an average maintained foot-candle intensity of at least one (1) foot-candle with a minimum allowable intensity of three-tenths of a foot-candle. The covered parking area of any hotel, motel, or extended-stay hotel shall have an average maintained foot-candle intensity of five-tenths of a foot-candle.
- (3) Graffiti and markings or insignia that may indicate the presence or association of a street gang shall be removed within 24 hours.

Sec. 8-506. - Smoking.

- (1) Smoking is prohibited in all hotel, motel, or extended-stay hotel spaces with the exception of designated smoking rooms. Designated smoking rooms in hotels rented by guests shall not comprise more than twenty-five percent (25%) of the total number of rooms available for rent.
- (2) Smoking is prohibited in exterior breezeways, stairwells, or within 25 feet of any guest room.

Sec. 8-507. – Video Surveillance Systems.

- (1) For the purpose of this section, "Video Surveillance System" (VSS) means a continuous digital surveillance system including cameras, cabling, monitors,

and digital video recorders (DVR) which has been approved by the Chief of Police or his/her designee in accordance with this section.

- (2) Every owner, operator, keeper or proprietor of any hotel, motel, or extended-stay hotel is required to install a VSS. All hotels, motels, and extended-stay hotels which have installed a VSS prior to the effective date of this ordinance shall ensure said systems are in full compliance with this section and request an approval assessment from the Chief of Police or his/her designee within thirty (30) days of the effective date of this ordinance.
- (3) All VSS shall be maintained in proper working order at all times, be kept in continuous operation 24 hours a day, 7 days a week, and meet the minimum technological standards established in this section. The hotel, motel, or extended-stay hotel shall retain the continuous digital images recorded by this system for no less than thirty (30) days.
- (4) All VSS shall have no less than one camera dedicated to each register or check-out stand, entrance/exit, interior hallway and lobby, swimming pool area, exercise facility, loading dock, and parking lots or areas designated for customer and/or employee parking use. The placement of cameras included in VSS required under this section must be approved by the Police Department. The Chief of Police or his/her designee will conduct an assessment of each site required to install a VSS prior to installation of said system, and upon approval will issue an approval notice which will be placed in plain view inside the common area of the hotel, motel, or extended-stay hotel. This approval notice will also inform customers and employees of the presence of the VSS. Existing VSS at any hotel, motel, or extended-stay hotel as of the effective date of this ordinance will be evaluated to ensure full compliance with this section.
- (5) The VSS shall be subject to regular inspection by the Chief of Police or his/her designee, who is authorized to inspect any such System at reasonable times to determine whether it conforms to this section. If the VSS does not conform, the hotel, motel, or extended-stay hotel in question shall take immediate steps to bring the system back into compliance.

Sec. 8-508. - Loitering.

- (1) All hotel, motel, or extended-stay hotel operators will advise patrons and guests, in writing upon registration, that loitering on or about hotel property by patrons, guests and their visitors is prohibited.
- (2) No person(s) shall loiter in or upon any hotel, motel, or extended-stay hotel parking lot, public parking structure or in or around any building to include breezeways, stairwells or hotel, motel, or extended-stay hotel rooms either on foot or in or upon any conveyance being driven or parked thereon, without the

permission of the owner, operator, keeper or proprietor of the hotel, motel, or extended-stay hotel.

Sec. 8-509 – 8-519. – *Reserved*

Sec. 8-520. - *Violations and penalties.*

- (1) Any person or other entity violating the provisions of this article shall be punishable by a fine not to exceed \$1,000.00 per violation or by imprisonment for a period not to exceed 180 days, or by both such fine or imprisonment. Such persons shall be guilty of a separate offense for each and every day during which any violation of any provision of this article is committed, continued, or permitted by that person and shall be punished accordingly.
- (2) The violation of the provisions of this article may be abated as a nuisance.
- (3) The violation of all provisions of this article by any person may be enjoined by instituting appropriate proceedings for injunction in any court of competent jurisdiction. Such actions may be maintained notwithstanding that other adequate remedies at law exist. Such actions may be instituted in the name of the Board of Commissioners.

Sec. 8-521. - *Responsibility for enforcement.*

- (1) The DeKalb County Police Department shall have the responsibility for the enforcement of this section. Sworn officers of the DeKalb County Police Department and civilian employees designated by the Chief of Police shall have the authority to inspect establishments governed under this section during the hours in which the premises are open for business.
- (2) These inspections shall be made for the purpose of verifying compliance with the requirements of this section and state law.

Sec. 8-522. - *Unlawful operation declared nuisance.*

- (1) Any hotel, motel, or extended-stay hotel operated, conducted or maintained contrary to the provisions of this article may be declared to be unlawful and a public nuisance. The county may, in addition, or in lieu of all other remedies, commence actions or proceedings for abatement, removal or enjoinder thereof, in the manner provided by state law and the County of DeKalb Code of Ordinances.

(2) No hotel, motel, or extended-stay hotel shall operate at any location nor on any premises which does not comply with all zoning, building code, fire safety code, and other ordinances and laws of the county and the state.

* * *

Sec. through . Reserved.

PART II. EFFECTIVE DATE

This ordinance shall become effective immediately on the date of adoption by the board of commissioners and approval by the chief executive officer.

PART III. SEVERABILITY

Should any section or provision of this ordinance be declared by a court of competent jurisdiction to be invalid or unconstitutional, such decision shall not affect the validity of the ordinance as a whole nor any part thereof other than the part so declared to be invalid or unconstitutional. All ordinances or resolutions, or parts thereof, in conflict with this ordinance are repealed.

ADOPTED by the DeKalb County Board of Commissioners, this _____ day of _____, 2016.

LARRY JOHNSON, MPH
Presiding Officer
Board of Commissioners
DeKalb County, Georgia

APPROVED by the Chief Executive Officer of DeKalb County, this _____ day of _____, 2016.

LEE MAY
Interim Chief Executive Officer
DeKalb County, Georgia

ATTEST:

BARBARA SANDERS-NORWOOD, CCC
Clerk to the Board of Commissioners
And Chief Executive Officer
DeKalb County, Georgia

APPROVED AS TO FORM:

O.V. BRANTLEY
County Attorney
DeKalb County, Georgia

APPROVED AS TO SUBSTANCE:

LUZ BORRERO
Deputy Chief Operating Officer
for Development
DeKalb County, Georgia

REV.

DEKALB COUNTY

ITEM NO. 12

BOARD OF COMMISSIONERS

BUSINESS AGENDA / MINUTES

MEETING DATE: March 28, 2017

HEARING TYPE

Action

ACTION TYPE

Resolution

SUBJECT: Multi-Family Housing Blight Resolution

DEPARTMENT: BOC

PUBLIC HEARING: NO

ATTACHMENT: YES

INFORMATION CONTACT: Commissioner Larry Johnson
Presiding Officer

PAGES: 2

PHONE NUMBER:

Deferred 12/13/16, 1/10/17, 2/14/17

PURPOSE: To enact a resolution establishing a road map to address various issues related to remedying blight in multi-family housing developments.

NEED/IMPACT: To address problems related to remedying blighted multi-family properties in a systematic and orderly fashion.

RECOMMENDATION(S): To approve the attached resolution and authorize the CEO to enact all necessary documents.

MAR 28 2017
[Handwritten signature]

MAR 28 2017
[Handwritten signature]

FOR USE BY COMMISSION OFFICE/CLERK ONLY

ACTION : 2017-03-28 Item I2

MOTION was made by Jeff Rader, seconded by Larry Johnson and passed 7-0-0-0 to defer for one month until April 25, 2017, to approve a resolution of various issues related to blight in Multi-Family properties in DeKalb County, Georgia and for other purposes, and authorize the CEO to enact all necessary documents.

Items I1 and I2 were heard together.

ADOPTED: MAR 28 2017
(DATE)



PRESIDING OFFICER
DEKALB COUNTY BOARD OF
COMMISSIONERS

CERTIFIED: MAR 28 2017
(DATE)



CLERK,
DEKALB COUNTY BOARD
OF COMMISSIONERS

FOR USE BY CHIEF EXECUTIVE OFFICER ONLY

APPROVED: APR 05 2017
(DATE)

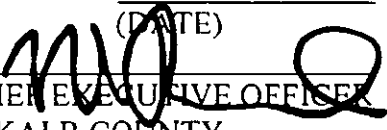

CHIEF EXECUTIVE OFFICER
DEKALB COUNTY

VETOED: _____
(DATE)

CHIEF EXECUTIVE OFFICER
DEKALB COUNTY

VETO STATEMENT ATTACHED: _____

MINUTES:

FOR : Kathie Gannon, Steve Bradshaw, Gregory Adams, Nancy Jester, Larry Johnson, Mereda Davis Johnson, Jeff Rader

AGAINST : None

ABSTAIN : None

ABSENT : None

RESOLUTION**A RESOLUTION BY THE GOVERNING AUTHORITY OF DEKALB COUNTY, GEORGIA, TO ESTABLISH A ROAD MAP FOR RESOLUTION OF VARIOUS ISSUES RELATED TO BLIGHT IN MULTI-FAMILY PROPERTIES IN DEKALB COUNTY, GEORGIA, AND FOR OTHER PURPOSES**

WHEREAS, the County recognizes that blighted multi-family properties cause significant problems within the community and need to be addressed in a systematic and orderly fashion;

WHEREAS, the County has established a Multi-Family Housing Task Force to coordinate activities to reduce blight in such properties;

WHEREAS, County staff have identified various administrative and legislative changes which will aid in the reduction of blight in these areas and others within the County;

WHEREAS; County staff have been working with the County Attorney and her staff to draft legislation that aids in the reduction of blight and attempts to ameliorate the public health, wealth and safety issues that arise in the course of trying to bring private property into compliance with various laws; and

WHEREAS, this Resolution creates a roadmap for resolution of various legal and administrative challenges which exist within blighted areas of the County;

NOW, THEREFORE, BE IT RESOLVED, by the Governing Authority as follows:

1. At the first commission meeting in January of 2017, the Executive Assistant has agreed to present an ordinance to the commission to adopt the International Property Maintenance Code.
2. At the first commission meeting in February of 2017, the Executive Assistant has agreed to present an ordinance revising the business license chapter of the Code of DeKalb County to provide clarified processes for issuance, suspension and revocation of business licenses.
3. The Executive Assistant and County Attorney shall work with the County's lobbyists to determine if state law can be amended to allow for a more efficient manner of dealing with blighted property while recognizing the due process rights of owners.
4. The Executive Assistant will investigate whether there are administrative changes—like using process servers to serve citations—which may make resolution of these various blight issues more efficient.
5. The Executive Assistant and County Attorney shall determine if there are ordinance changes which could alleviate blight in an efficient and legal manner.
6. The Executive Assistant and County Attorney shall periodically update the governing authority on their progress towards resolution of this matter.

ADOPTED by the DeKalb County Board of Commissioners, this ___ day of _____, 2016

LARRY JOHNSON
Presiding Officer
Board of Commissioners
DeKalb County, Georgia

APPROVED by the Chief Executive Officer of DeKalb County, this ___ day of _____, 2016.

W. BURRELL ELLIS, JR.
Chief Executive Officer
DeKalb County, Georgia

ATTEST:

BARBARA SANDERS-NORWOOD, CCC
Clerk to the Board of Commissioners and
Chief Executive Officer
DeKalb County, Georgia

APPROVED AS TO FORM:

O.V. BRANTLEY
County Attorney
DeKalb County, Georgia

DEKALB COUNTY

ITEM NO. 13

BOARD OF COMMISSIONERS

BUSINESS AGENDA / MINUTES

MEETING DATE: March 28, 2017

HEARING TYPE

Action

ACTION TYPE

Resolution

SUBJECT: To consider the proposed resolution calling for a SPLOST and E-HOST referendum on NEXT AVAILABLE DATE

DEPARTMENT: Board of Commissioners

PUBLIC HEARING: NO

ATTACHMENT: YES

14

PAGES:

INFORMATION VIS A S GAW
CONTACT: Commissioner Mereda Davis Johnson

PHONE NUMBER: (404) 371-2159

Normal Coursed 12/13/16; Deferred 1/10/17, 1/24/17, 2/14/17 & 3/14/17

PURPOSE:

To consider approving the attached resolution calling for a SPLOST and E-HOST referendum on NEXT AVAILABLE DATE

NEED/IMPACT:

The administration has worked over the last several months to prepare for holding a referendum on NEXT AVAILABLE DATE in which voters may decide to approve a 1% SPLOST for transportation and capital improvement projects and to reform HOST to create E-HOST and provide additional property tax relief countywide. A SPLOST is projected to generate approximately \$551 million countywide of which \$378 million will be allocated to unincorporated DeKalb County, while E-HOST is projected to generate \$113 million in additional tax credits for county homeowners.

The SPLOST Citizen Advisory Committee (CAC) held 11 public meetings and one driving tour of the county to learn about SPLOST and E-HOST, to ascertain DeKalb's transportation and capital needs in each department, and to develop a list of recommended projects. The CAC finalized their recommended project list on April 27, 2016 and presented their recommendations to the Board of Commissioners on May 3, 2016. To ensure the use of taxpayer funds is transparent and accountable, we recommend that the Board of Commissioners approve a SPLOST project list attached to this Resolution. An Exhibit for each City's List of Projects is also attached to the Resolution.

In order to call for a referendum for SPLOST and E-HOST on November 8, 2016, the Board of Commissioners must adopt a resolution calling for the referendum and transmit that resolution to the Elections Superintendent on or before NEXT AVAILABLE DATE

RECOMMENDATION(S):

To approve the attached resolution calling for a SPLOST and E-HOST referendum to be implemented in DeKalb County on NEXT AVAILABLE DATE and authorize the CEO to execute all necessary documents.

FOR USE BY COMMISSION OFFICE/CLERK ONLY

ACTION : 2017-03-28 Item 13

MOTION was made by Mereda Davis Johnson, seconded by Gregory Adams and passed 7-0-0-0 to defer for 30 days until April 25, 2017, to approve the attached resolution calling for a SPLOST and E-HOST referendum to be implemented in DeKalb County and authorize the CEO to execute all necessary documents.

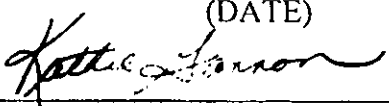
ADOPTED: MAR 28 2017
(DATE)

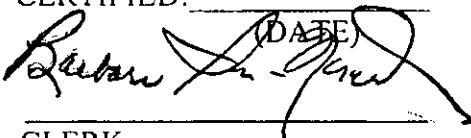
PRESIDING OFFICER
DEKALB COUNTY BOARD OF
COMMISSIONERS

CERTIFIED: MAR 28 2017
(DATE)

CLERK,
DEKALB COUNTY BOARD
OF COMMISSIONERS

FOR USE BY CHIEF EXECUTIVE OFFICER ONLY

APPROVED: APR 05 2017
(DATE)
CHIEF EXECUTIVE OFFICER
DEKALB COUNTY

VETOED: _____
(DATE)
CHIEF EXECUTIVE OFFICER
DEKALB COUNTY

VETO STATEMENT ATTACHED: _____

MINUTES:

FOR : Kathie Gannon, Steve Bradshaw, Gregory Adams, Nancy Jester, Larry Johnson, Mereda Davis Johnson, Jeff Rader

AGAINST : None

ABSTAIN : None

ABSENT : None

A RESOLUTION OF THE DEKALB COUNTY, GEORGIA GOVERNING AUTHORITY TO SUSPEND THE CURRENT HOMESTEAD OPTION SALES AND USE TAX AND LEVY AN EQUALIZED HOMESTEAD OPTION SALES AND USE TAX; TO IMPOSE A ONE PERCENT SPECIAL PURPOSE LOCAL OPTION SALES AND USE TAX; SPECIFY THE PURPOSES FOR WHICH THE PROCEEDS OF SUCH TAXES ARE TO BE USED; REQUEST THE ELECTION SUPERINTENDENT TO CALL AN ELECTION OF THE VOTERS OF DEKALB COUNTY TO APPROVE THE IMPOSITION OF SUCH SALES AND USE TAXES; APPROVE THE FORM OF BALLOT TO BE USED IN SAID ELECTIONS; AND FOR OTHER PURPOSES.

WHEREAS, Part 2 of Article 2A of Chapter 8 of Title 48 of the Official Code of Georgia Annotated allows suspension of the homestead option sales and use tax authorized by O.C.G.A. § 48-8-102 (the "HOST") and replacement of such tax with the imposition of an equalized homestead option sales and use tax (the "EHOST") for the purpose of reducing the ad valorem property tax millage rates levied by the county and municipalities on homestead properties; and

WHEREAS, Part 1 of Article 3 of Chapter 8 of Title 48 of the Official Code of Georgia Annotated authorizes the imposition of a county one percent sales and use tax (the "SPLOST") for the purpose, inter alia, of financing certain county and municipal capital outlay projects which include those set forth herein; and

WHEREAS, pursuant to O.C.G.A. § 48-8-109.2 the referendum election to determine whether to impose an EHOST must be held in conjunction with the referendum election to approve a SPLOST and unless both sales and use taxes are approved, neither shall become effective and HOST will continue without interruption; and

WHEREAS, the Governing Authority of DeKalb County, Georgia (the "Governing Authority") has determined that it is in the best interest of the citizens of DeKalb County, Georgia (the "County") to suspend HOST and impose an EHOST to apply 100% of the proceeds collected from the tax to reduce ad valorem property tax millage rates and that it is further in the best interest of the County to impose a one percent SPLOST in a special district within the County to raise approximately *[\$661,000,000.00 for five years or \$793,000,000.00 for six years]* for the purpose of funding certain County and Municipal capital outlay projects, described in Exhibit A and Exhibit B, respectively, attached hereto (the "County Projects" and the "City Projects" or collectively the "Projects"); and

WHEREAS, the Governing Authority of DeKalb County mailed a written notice (the "Notice") to the Mayor in each municipality located within the County, except that portion of the City of Atlanta in the County, which is excluded from receiving SPLOST proceeds at this time pursuant to O.C.G.A. § 48-8-109.5(f) regarding the imposition of the SPLOST (hereinafter the "Municipalities"); and

WHEREAS, the Notice contained the date, time, place, and purpose of a meeting at which designated representatives of DeKalb County and the Municipalities met and discussed the possible projects for inclusion in the referendum, including municipally owned and operated projects; and

WHEREAS, the Notice was delivered or mailed at least 10 days prior to the date of the meeting, and the meeting was held at least 30 days prior to the issuance of a call for the referendum; and

WHEREAS, the County has *[or has not]* entered into an intergovernmental agreement with the Municipalities; and

WHEREAS, the Municipalities represent approximately thirty percent (30%) of the total population of the County.

NOW, THEREFORE, BE IT RESOLVED by the Governing Authority of DeKalb County, Georgia, as follows:

- A. Assuming the questions of imposing a County EHOST and SPLOST are approved by the voters of the special district in the election hereinafter referred to, the imposition of a one percent (1%) equalized homestead option sales and use tax shall be authorized and levied for the purposes allowed by state law and as specified in O.C.G.A. §48-8-109.1 *et seq.*
- B. Assuming the questions of imposing a County EHOST and SPLOST are approved by the voters of the special district in the election hereinafter referred to, the SPLOST shall be imposed for the term, purposes and costs as follows:
 - 1. In order to finance the cost of the Projects, a SPLOST in the amount of one percent (1%) on all sales and uses in the County is hereby authorized to be levied and collected within the special district created in the County as provided in Part 1 of Article 3 of Chapter 8 of Title 48 of the Official Code of Georgia, except the SPLOST shall not be levied and collected within the boundaries of any municipality wholly or partially located within a special district levying a tax provided for in Article 4 of Chapter 8 of Title 48 of the Official Code of Georgia.
 - 2. Proceeds of such tax are to be used to fund the cost of the Projects. The Projects consist of "County Projects" and "City Projects." The County Projects, the Municipal Projects, and the estimated costs thereof are set forth in Exhibit A, and Exhibit B, respectively, attached hereto and incorporated herein by reference.
 - 3. Proceeds of the SPLOST shall be distributed according to the provisions of O.C.G.A. § 48-8-109.5(e) and (f). Because of annexations and new cities coming into existence after any decennial census, the County and the Municipalities have agreed on a Tax Certificate of Distribution *[and/or an Intergovernmental Agreement]* to account for changes in population between each decennial census. The SPLOST is to be imposed for a period of *[five (5)][six (6)]* years.
- C. **General Obligation Debt. [OPTIONAL – MAY OR MAY NOT BE INCLUDED IN FINAL –REQUIRES BOC APPROVAL]**
 - 1. The County is hereby authorized to issue general obligation debt (the "Debt"), for the County Projects secured by the proceeds of the SPLOST, in a maximum aggregate principal amount of \$_____. The Proceeds of the Debt, if issued, shall be used to pay a portion of the costs of the County Projects, and the costs of

issuing the Debt. The Debt shall bear interest from the date of issuance of the Debt or from such other date as may be designated by the County prior to the issuance of the Debt, at a rate(s) to be determined in a supplemental resolution to be adopted by the County prior to the issuance of the debt, which rate shall not exceed % per annum. The amount of principal to be paid in each year during the life of the Debt shall be as follows:

<u>Year</u>	<u>Amount</u>
-------------	---------------

2. The proceeds of the Debt shall be deposited by the County in separate funds or accounts. The SPLOST proceeds received in any year pursuant to the imposition of such tax, shall first be used for paying debt service requirements on the Debt for any such year before such proceeds are applied to any of the County Projects authorized above. Proceeds of the SPLOST not required to be deposited in the separate fund in any year for the payment of principal and interest on the Debt coming due in the current year shall be deposited in a separate fund to be maintained by the County and applied towards funding the County Projects to the extent such projects have not been funded with debt proceeds.

3. Any brochures, listings, or other advertisements issued by the Governing Authority or by any other person, firm, corporation or association with the knowledge and consent of the Governing Authority, shall be deemed to be a statement of intention of the Governing Authority concerning the use of the proceeds of the Debt, and such statement of intention shall be binding upon the Governing Authority in the expenditure of such Debt or interest received from such Debt to the extent provided in Section 36-82-1 of the Official Code of Georgia Annotated.

D. Call for the Election; Ballot Form; Notice.

1. The Board of Elections of DeKalb County is hereby requested to call an election in all voting precincts in the County on the 8th day of November, 2016, for the purpose of submitting to the qualified voters of the County the questions set forth in paragraphs 2 and 3 below.

2. The ballots to be used in the EHOST and SPLOST referendum election shall have written or printed thereon substantially the following:

NOTICE TO ELECTORS: Unless **BOTH** the equalized homestead option sales and use tax (EHOST) **AND** the special purpose local option sales and use tax (SPLOST) are approved, then neither sales and use tax shall become effective.

() YES	Shall an equalized homestead option sales and use tax be levied and the regular homestead option sales and use tax be suspended within the special district within
---------	--

() NO	DeKalb County for the purposes of reducing the ad valorem property tax millage rates levied by the County and municipal governments on homestead properties?
--------	--

() YES	Shall a special 1 percent sales and use tax be imposed in the special district of DeKalb County for a period of time not to exceed [5 or 6] years and for the raising of an estimated amount of [\$661,000,000.00 for five years or \$793,000,000.00 for six years] for the purpose of funding capital improvement projects related to (1) County roads, streets, bridges and sidewalks; (2) County transportation equipment, (3) County technology equipment and materials; (4) constructing, adding to, renovating, replacing, improving, furnishing, and equipping existing or new County parks and recreation facilities, County library facilities, County public safety facilities, and other County governmental facilities, including necessary demolition; and (5) paying expenses incident to accomplishing the foregoing? [City Projects to be added]
() NO	

If imposition of the taxes are approved by more than one-half of the voters, such vote shall also constitute approval of the issuance of general obligation debt of DeKalb County in the principal amount of \$_____ for the above County Projects, to pay capitalized interest incident thereto, and to pay expenses incident to accomplishing the foregoing. *[GO DEBT ISSUE IS OPTIONAL AND MAY OR MAY NOT BE INCLUDED IN FINAL-REQUIRES BOC APPROVAL]*

3. It is hereby requested that the election be held by the Board of Elections of DeKalb County in accordance with the election laws of the State of Georgia, including, without limitation, the election laws relating to special elections. It is hereby further requested that the Board of Elections of DeKalb County canvass the returns declare the results of the election and certify the result to the Secretary of State and to the Commissioner of Revenue.
 4. The Board of Elections of DeKalb County is hereby authorized and requested to publish a notice of election as required by law in the newspaper in which Sheriff's advertisements for the County are published once a week for four weeks immediately preceding the date of the election. The notice of the election shall be in substantially the form attached hereto as Exhibit C.
- E. The Clerk of the Governing Authority is hereby authorized and directed to deliver a copy of the resolution to the Board of Elections of DeKalb County, with a request that the Board of Elections of DeKalb County issue the call for an election.

F. The proper officers and agents of the County are hereby authorized to take any and all further actions as may be required in connection with the imposition of the EHOST and SPLOST.

ADOPTED by the DeKalb County Board of Commissioners, this _____ day of _____, 2016.

LARRY JOHNSON, MPH
Presiding Officer

ADOPTED by the Chief Executive Officer of DeKalb County, this _____ day of _____, 2016.

LEE MAY
Interim Chief Executive Officer

ATTEST:

BARBARA SANDERS-NORWOOD, CMC
Clerk

APPROVED AS TO FORM:

O.V. BRANTLEY
County Attorney

EXHIBIT "A"

EXHIBIT "B"

EXHIBIT C

TO THE QUALIFIED VOTERS OF DEKALB COUNTY, GEORGIA

NOTICE IS HEREBY GIVEN that on the 8th day of November, 2016, an election will be held at the regular polling places in the election districts of DeKalb County, Georgia, (the "County"), at which time there will be submitted to the qualified voters of the County for their determination two questions. The first question will be whether an equalized homestead option sales and use tax (the "EHOST") be levied and the regular homestead option sales and use tax be suspended within the special district of the County for the purposes of reducing the ad valorem property tax millage rates levied by the County and municipal governments on homestead properties. The second question will be whether a one percent county special purpose local option sales and use tax (the "SPLOST") shall be imposed on all sales and uses in the special district created in the County for a period of _____ years for the raising of approximately \$_____ for the purpose of funding certain capital outlay projects ("the Projects") specified in the form of the ballot set forth below.

The ballots to be used at said election shall have written or printed thereon substantially the following:

NOTICE TO ELECTORS: Unless **BOTH** the equalized homestead option sales and use tax (EHOST) **AND** the special purpose local option sales and use tax (SPLOST) are approved, then neither sales and use tax shall become effective.

<input type="checkbox"/> YES	Shall an equalized homestead option sales and use tax be levied and the regular homestead option sales and use tax be suspended within the special district within DeKalb County for the purposes of reducing the ad valorem property tax millage rates levied by the County and municipal governments on homestead properties?
<input type="checkbox"/> NO	

<input type="checkbox"/> YES	Shall a special 1 percent sales and use tax be imposed in the special district of DeKalb County for a period of time not to exceed [5 or 6] years and for the raising of an estimated amount of [\$661,000,000.00 for five years or \$793,000,000.00 for six years] for the purpose of funding capital improvement projects related to (1) County roads, streets, bridges and sidewalks; (2) County transportation equipment, (3) County technology equipment and materials; (4) constructing, adding to, renovating, replacing, improving, furnishing, and equipping existing or new County parks and recreation facilities, County library facilities, County public safety facilities, and other County governmental facilities,
<input type="checkbox"/> NO	

including necessary demolition; and (5) paying expenses incident to accomplishing the foregoing? *[City Projects to be added]*

If imposition of the taxes are approved by more than one-half of the voters, such vote shall also constitute an approval of the issuance of general obligation debt of the County secured by the SPLOST in the maximum aggregate principal amount not to exceed \$ _____ (“the Debt”). The proceeds of the Debt, if issued, shall be used to pay the costs of one or more of the County Projects, the costs of issuing the Debt and to pay capitalized interest incident thereto and to pay expenses incident to accomplishing the foregoing. *[GO DEBT PROVISION IS OPTIONAL AND MAY OR MAY NOT BE INCLUDED IN THE FINAL- REQUIRES BOC APPROVAL]*

Notwithstanding any other provision of law to the contrary, the statement and ballot questions above shall precede any and all other special election ballot questions which are to appear on the same ballot. O.C.G.A. § 48-8-109.4.

All persons desiring to vote in favor of levying the taxes shall vote “Yes”, and persons opposed to the levying of the taxes shall vote “No”. If more than one-half of the votes are cast in favor of levying the taxes, then both of the taxes shall be levied in accordance with applicable state law, otherwise the taxes may not be levied.

The last day to register to be eligible to vote in this election is _____, 2016. The referendum will be held in all the regular polling precincts and election districts of DeKalb County, Georgia. The polls will open at 7:00 AM and close at 7:00 PM.

Those residents qualified to vote at said election shall be determined in all respects in accordance with the election laws of the State of Georgia.

This notice is given pursuant to a resolution of the DeKalb County Governing Authority and the DeKalb County Board of Elections and Registration.

This ___ day of _____, 2016

H. Maxine Daniels, Elections Supervisor
For: The DeKalb County Board of Registration and Elections

PLEASE PUBLISH: [in the Champion once a week for four weeks immediately preceding the election]

Citizen Advisory Committee (CAC) SPLOST Project List: Projects Recommended for Funding

6/3/16

13

Project ID ¹	Project Title	Estimated Cost to County	List A ² (Projects recommended for funding)	% of Total Funding	List B ³ (projects to be defunded if lower revenues)	List C ⁴ (projects to be added if higher revenues)
Department of Roads & Drainage						
Department Total		\$163,629,250	\$162,029,250	42.89%	\$0	\$21,600,000
RD-1	BUTLERS LN ROAD RATING = 38	\$68,000	\$68,000	0.02%	\$0	\$0
RD-2	WELLHOUSE WALK ROAD RATING = 36	\$42,500	\$42,500	0.01%	\$0	\$0
RD-3	MULTIPLE PROJECTS (20) ROAD RATING = 35	\$1,738,250	\$1,738,250	0.46%	\$0	\$0
RD-4	MULTIPLE PROJECTS (219) ROAD RATING = 34	\$20,825,000	\$20,825,000	5.51%	\$0	\$0
RD-5	MULTIPLE PROJECTS (268) ROAD RATING = 33	\$32,882,250	\$32,882,250	8.70%	\$0	\$0
RD-6	MULTIPLE PROJECTS (332) ROAD RATING = 32	\$38,764,250	\$38,764,250	10.26%	\$0	\$0
RD-7	MULTIPLE PROJECTS (286) ROAD RATING = 31	\$35,738,250	\$35,738,250	9.46%	\$0	\$0
RD-8	MULTIPLE PROJECTS (261) ROAD RATING = 30	\$33,570,750	\$31,970,750	8.46%	\$0	\$1,600,000
RD-9	MULTIPLE PROJECTS ROAD RATING < 30	\$0	\$0	0.00%	\$0	\$20,000,000
Department of Public Works - Transportation Division						
Department Total		\$62,030,000	\$54,950,000	14.55%	\$0	\$7,050,000
PW-1	DeKalb Sidewalk Program: Phase 2	\$1,600,000	\$1,600,000	0.42%	\$0	\$0
PW-2	South River Trail - Phase V	\$1,200,000	\$1,200,000	0.32%	\$0	\$0
PW-3	Panola Road Improvements	\$5,500,000	\$5,500,000	1.46%	\$0	\$0
PW-4	Rockbridge Road Improvements	\$1,000,000	\$1,000,000	0.26%	\$0	\$0
PW-6	Upgrades to Clifton Rd, Church St and Clairmont Rd Traffic Signals	\$400,000	\$400,000	0.11%	\$0	\$0
PW-7	Turner Hill Road Widening	\$5,300,000	\$5,300,000	1.40%	\$0	\$0
PW-8	Glenwood Road Sidewalks	\$4,200,000	\$4,200,000	1.11%	\$0	\$0
PW-9	Redan Rd. at S. Stone Mountain Lithonia Traffic Signal	\$350,000	\$350,000	0.09%	\$0	\$0
PW-10	Sidewalk Gaps and ADA Upgrades	\$5,000,000	\$5,000,000	1.32%	\$0	\$0
PW-11	North Clarendon Ave. at East Ponce Railroad Preemption	\$300,000	\$300,000	0.08%	\$0	\$0
PW-12	Mountain View Road Sidewalks	\$2,000,000	\$2,000,000	0.53%	\$0	\$0
PW-13	Lavista Road Sidewalks and Turn Lanes	\$3,000,000	\$3,000,000	0.79%	\$0	\$0
PW-14	McAfee Sidewalks	\$4,000,000	\$4,000,000	1.06%	\$0	\$0
PW-15	North Decatur Road Safety Improvements	\$2,000,000	\$2,000,000	0.53%	\$0	\$0
PW-16	Mercer University Bridge at N. Fork Peachtree Creek	\$1,500,000	\$1,500,000	0.40%	\$0	\$0
PW-17	Covington Highway Sidewalks	\$8,000,000	\$8,000,000	2.12%	\$0	\$0
PW-18	North Druid Hills Bridge/CSX	\$5,000,000	\$5,000,000	1.32%	\$0	\$0
PW-19	Multi-Use Trail Connection to Kensington MARTA Station	\$4,000,000	\$4,000,000	1.06%	\$0	\$0
PW-20	North Druid Hills Road Sidewalk	\$300,000	\$300,000	0.08%	\$0	\$0

Citizen Advisory Committee (CAC) SPLOST Project List: Projects Recommended for Funding
6/3/16

Project ID ¹	Project Title	Estimated Cost to County	List A ² (Projects recommended for funding)	% of Total Funding	List B ³ (projects to be defunded if lower revenues)	List C ⁴ (projects to be added if higher revenues)
PW-21	Lithonia Industrial Boulevard	\$250,000	\$0	0.00%	\$0	\$250,000
PW-23	Goldsmith Rd. at East Ponce Railroad Preemption	\$300,000	\$300,000	0.08%	\$0	\$0
PW-25	HF Shepherd Drive Sidewalks	\$630,000	\$0	0.00%	\$0	\$600,000
PW-27	Turner Hill Road Sidewalks	\$450,000	\$0	0.00%	\$0	\$450,000
PW-28	Pleasantdale Road Pedestrian Crossings	\$250,000	\$0	0.00%	\$0	\$250,000
PW-29	Shadow Rock Road at South Stone Mountain Lithonia Road Traffic Signal	\$200,000	\$0	0.00%	\$0	\$200,000
PW-31	Stephenson Rd. at South Deshon Rd. Intersection	\$500,000	\$0	0.00%	\$0	\$500,000
PW-37	DeKalb Industrial Way at Milscott Drive Pedestrian Improvements	\$300,000	\$0	0.00%	\$0	\$300,000
PW-38	South Fork Peachtree Creek Trail	\$500,000	\$0	0.00%	\$0	\$500,000
PW-44	CID Matches	\$4,000,000	\$0	0.00%	\$0	\$4,000,000
Department of Library Services						
Department Total		\$15,275,000	\$11,275,000	2.98%	\$11,275,000	\$4,000,000
LS-1	RFID Conversion & ILS Upgrade	\$1,200,000	\$1,200,000	0.32%	\$1,200,000	\$0
LS-2	System-wide Technology Infrastructure	\$1,250,000	\$1,250,000	0.33%	\$1,250,000	\$0
LS-3	Wesley Chapel-WCB Library	\$4,300,000	\$4,300,000	1.14%	\$4,300,000	\$0
LS-9	Redan-Trotti Library	\$4,300,000	\$4,300,000	1.14%	\$4,300,000	\$0
LS-11	Covington Library	\$2,000,000	\$0	0.00%	\$0	\$2,000,000
LS-12	Flat Shoals Library	\$2,000,000	\$0	0.00%	\$0	\$2,000,000
LS-15	Sidewalk Completion	\$225,000	\$225,000	0.06%	\$225,000	\$0
Department of Parks & Recreation						
Department Total		\$42,200,000	\$34,300,000	9.08%	\$34,300,000	\$7,900,000
PR-1	Bouldercrest Park: Playground	\$300,000	\$300,000	0.08%	\$300,000	\$0
PR-2	Midway Park: Playground	\$200,000	\$200,000	0.05%	\$200,000	\$0
PR-3	Shoals Creek 1 Park: Playground	\$200,000	\$200,000	0.05%	\$200,000	\$0
PR-4	Shoals Creek 3 Park: Playground, Trails	\$200,000	\$200,000	0.05%	\$200,000	\$0
PR-5	Pleasantdale Park: Playground	\$200,000	\$200,000	0.05%	\$200,000	\$0
PR-6	Truelove Park: Playground	\$200,000	\$200,000	0.05%	\$200,000	\$0
PR-7	Oak Creek: Playground	\$200,000	\$200,000	0.05%	\$200,000	\$0
PR-8	Emmie Smith: Playground	\$200,000	\$200,000	0.05%	\$200,000	\$0
PR-9	Flat Shoals Park: Playground Repair, Repair on Trails	\$500,000	\$500,000	0.13%	\$500,000	\$0
PR-10	Ellenwood Park / 46 Acre Park: New Design per Master Plan (Grading, Parking, Basketball, Playground, Trails, Boardwalk/Overlook System, Bridge, Benches, Trash Receptacles)	\$2,000,000	\$2,000,000	0.53%	\$2,000,000	\$0
PR-11	Rainbow Park / Porter Sanford Performance Arts Center: Redesign of Garden Area for Outdoor Events, Amphitheater	\$1,400,000	\$1,400,000	0.37%	\$1,400,000	\$0
PR-12	Brookside Park: Trails, Pavilions, Site Furnishings, Courts	\$1,000,000	\$1,000,000	0.26%	\$1,000,000	\$0

Citizen Advisory Committee (CAC) SPLOST Project List: Projects Recommended for Funding
6/3/16

Project ID ¹	Project Title	Estimated Cost to County	List A ² (Projects recommended for funding)	% of Total Funding	List B ³ (projects to be defunded if lower revenues)	List C ⁴ (projects to be added if higher revenues)
PR-13	Salem Park: Playground, Site Furnishings	\$200,000	\$200,000	0.05%	\$200,000	\$0
PR-14	Emory Grove Park: Playground, Site Furnishings	\$200,000	\$200,000	0.05%	\$200,000	\$0
PR-15	Princeton Park: Playground, Site Furnishings	\$200,000	\$200,000	0.05%	\$200,000	\$0
PR-16	Longdale Park: Playground, Site Furnishings	\$200,000	\$200,000	0.05%	\$200,000	\$0
PR-17	Shoals Creek I: Fence, Irrigation, Backstops, Restroom, Sod	\$1,500,000	\$1,500,000	0.40%	\$1,500,000	\$0
PR-18	Midway Park: Fence, Scoreboards, Restrooms	\$1,500,000	\$1,500,000	0.40%	\$1,500,000	\$0
PR-19	Exchange Park: Restroom at Baseball, Irrigation, Fence	\$1,500,000	\$1,500,000	0.40%	\$1,500,000	\$0
PR-20	Avondale Dunaire Park: Bathroom, Irrigation, Fence Repair, Sod, Redesign Fields	\$2,000,000	\$2,000,000	0.53%	\$2,000,000	\$0
PR-21	Truelove Park: Update Wooden Light Poles, Lighting, Fence, Irrigation, Backstops	\$1,500,000	\$1,500,000	0.40%	\$1,500,000	\$0
PR-22	Southeast Athletic Complex: Lighting, Soccer Fields, Restrooms	\$2,000,000	\$2,000,000	0.53%	\$2,000,000	\$0
PR-23	Kittredge Park Phase 2: Field Improvements, Dugouts	\$500,000	\$500,000	0.13%	\$500,000	\$0
PR-24	N.H. Scott Park: 2 Pavilion, Restroom	\$800,000	\$800,000	0.21%	\$800,000	\$0
PR-25	Emmie Smith: Ground Upkeep, Site Furnishings	\$500,000	\$500,000	0.13%	\$500,000	\$0
PR-26	Lou Walker Park: New Flooring, Pavilion	\$600,000	\$300,000	0.08%	\$300,000	\$300,000
PR-27	Glen Emerald Park: Pavilion, Restroom, Trails, Site Furnishings	\$1,200,000	\$1,200,000	0.32%	\$1,200,000	\$0
PR-28	Rock Chapel II: Parking Lot, Entrance	\$500,000	\$500,000	0.13%	\$500,000	\$0
PR-29	Chapel Hill Park: Trails	\$600,000	\$600,000	0.16%	\$600,000	\$0
PR-30	CAC - Community Achievement Center: Facility Renovation	\$1,600,000	\$800,000	0.21%	\$800,000	\$800,000
PR-31	Gresham Park: Restroom, Erosion Control, Landscaping, Pavilion	\$2,200,000	\$1,200,000	0.32%	\$1,200,000	\$1,000,000
PR-32	County Line: Pavilion, Amphitheater	\$1,500,000	\$1,000,000	0.26%	\$1,000,000	\$500,000
PR-33	Fork Creek Mountain Park: Trails, Fishing Piers, Interpretive Signage, Outdoor Classroom, Parking, Pavilion, Trash Receptacles	\$1,000,000	\$1,000,000	0.26%	\$1,000,000	\$0

6/3/16

Project ID ¹	Project Title	Estimated Cost to County	List A ² (Projects recommended for funding)	% of Total Funding	List B ³ (projects to be defunded if lower revenues)	List C ⁴ (projects to be added if higher revenues)
PR-34	Truelove Park: Landscaping, Erosion Control, Parking Lot	\$600,000	\$600,000	0.16%	\$600,000	\$0
PR-35	Summergate Park: Bench, Lights, Grill	\$500,000	\$500,000	0.13%	\$500,000	\$0
PR-36	Tobie Grant: Demolition, Redefining Complex & Entrance	\$1,400,000	\$1,400,000	0.37%	\$1,400,000	\$0
PR-37	46 Acre / Ellenwood Park: As per the 2015 Master Plan	\$9,000,000	\$6,000,000	1.59%	\$6,000,000	\$3,000,000
PR-47	Hairston Park: Widen Dam Crest, Replace Low Level Drain, Remove Vegetation, Provide Freeboard	\$1,500,000	\$0	0.00%	\$0	\$1,500,000
PR-69	County Line Park - asphalt service drive and parking lot	\$300,000	\$0	0.00%	\$0	\$300,000
PR-71	Chapel Hill Park:	\$500,000	\$0	0.00%	\$0	\$500,000
Department of Fire Services						
Department Total		\$69,180,000	\$46,670,000	12.35%	\$0	\$7,510,000
FS-2	Reconstruction of Existing Fire Station: No. 7	\$3,300,000	\$3,300,000	0.87%	\$0	\$0
FS-5	Reconstruction of Existing Fire Station: No. 13	\$3,500,000	\$3,500,000	0.93%	\$0	\$0
FS-6	Reconstruction of Existing Fire Station: No. 14	\$3,600,000	\$3,600,000	0.95%	\$0	\$0
FS-7	Reconstruction of Existing Fire Station: No. 16	\$3,500,000	\$3,500,000	0.93%	\$0	\$0
FS-8	Quick Response Unit	\$250,000	\$250,000	0.07%	\$0	\$0
FS-9	Quick Response Unit	\$250,000	\$250,000	0.07%	\$0	\$0
FS-10	Quick Response Unit	\$250,000	\$250,000	0.07%	\$0	\$0
FS-11	Quick Response Unit	\$250,000	\$250,000	0.07%	\$0	\$0
FS-12	Quick Response Unit	\$250,000	\$250,000	0.07%	\$0	\$0
FS-13	Construction of additional Fire Station: No. 27	\$3,880,000	\$3,880,000	1.03%	\$0	\$0
FS-14	Construction of additional Fire Station: No. 28	\$3,800,000	\$3,800,000	1.01%	\$0	\$0
FS-15	Construction of additional Fire Station: No. 29	\$5,130,000	\$5,130,000	1.36%	\$0	\$0
FS-17	Construction of additional Fire Station: No. 31	\$3,680,000	\$3,680,000	0.97%	\$0	\$0
FS-18	Construction of additional Fire Station: No. 32	\$5,030,000	\$5,030,000	1.33%	\$0	\$0
FS-20	Construction of additional Fire Station: No. 33	\$3,730,000	\$0	0.00%	\$0	\$3,730,000
FS-22	Construction of additional Fire Station: No. 35	\$3,780,000	\$0	0.00%	\$0	\$3,780,000

Project ID ¹	Project Title	Estimated Cost to County	List A ² (Projects recommended for funding)	% of Total Funding	List B ³ (projects to be defunded if lower revenues)	List C ⁴ (projects to be added if higher revenues)
FS-23	Co-location of Fire Academy and Logistics Hub	\$25,000,000	\$10,000,000	2.65%	\$0	\$0
Department of Police Services						
Department Total		\$44,200,000	\$24,200,000	6.41%	\$0	\$5,000,000
PS-1	Take Home Program	\$5,000,000	\$5,000,000	1.32%	\$0	\$0
PS-2	Hardware	\$5,000,000	\$5,000,000	1.32%	\$0	\$0
PS-3	Body Cameras	\$2,000,000	\$2,000,000	0.53%	\$0	\$0
PS-4	Property Room	\$2,200,000	\$2,200,000	0.58%	\$0	\$0
PS-10	Training Academy Facility	\$25,000,000	\$10,000,000	2.65%	\$0	\$0
PS-12	E911 Center	\$5,000,000	\$0	0.00%	\$0	\$5,000,000
Facilities Management						
Department Total		\$49,345,700	\$44,345,700	11.74%	\$0	\$5,000,000
FM-1	Roof Repair/Replacement	\$5,114,600	\$5,114,600	1.35%	\$0	\$0
FM-2	HVAC/Chiller Repair/Replacement	\$2,170,100	\$2,170,100	0.57%	\$0	\$0
FM-3	Modernize and Elevators	\$2,061,000	\$2,061,000	0.55%	\$0	\$0
FM-5	DeKalb County Government Center	\$40,000,000	\$35,000,000	9.26%	\$0	\$5,000,000
TOTAL estimated cost of recommended projects		\$445,859,950	\$377,769,950	100%	\$45,575,000	\$58,060,000

Total funding of recommended list (A)	\$377,769,950
Total funding if lower revenues (A-B)	\$332,194,950
Total funding if higher revenues (A+C)	\$435,829,950

¹**Project ID Key**

FM: Facilities Management	PS: Police Services
FS: Fire Services	PW: Public Works
LS: Library Services	RD: Roads and Drainage
PR: Parks and Recreation	

²**List A (Projects recommended for funding):** Project List A includes the projects selected by the Citizen Advisory Committee to be funded by projected SPLOST revenue. This list includes projects for which total costs are equal to the projected SPLOST revenue. In some instances, recommended projects are partially funded.

³**List B (Projects to be defunded if lower revenues):** Project List B includes the projects that are recommended for exclusion from funding in the event that collected revenue falls short of the original projection. If revenues fell short of the original projection, the SPLOST project list would reflect List A less the projects on List B. The projects on List B are within the departments of Library Services and Parks and Recreation.

⁴**List C (projects to be added if higher revenues):** Project List C includes projects (or amounts of funding) that are recommended for addition to List A in the event that collected revenue exceeds the original projection. If revenues exceed the original projection, the SPLOST project list would reflect List A plus the projects on List C. In some instances, for projects on List A that are not recommended for full funding, the remainder of the funding necessary to reach the project's total estimated cost is recommended on List C.

REV.

DEKALB COUNTY

ITEM NO. 14

BOARD OF COMMISSIONERS

BUSINESS AGENDA / MINUTES

MEETING DATE: March 28, 2017

HEARING TYPE
Action

ACTION TYPE
Ordinance

SUBJECT: Loitering Ordinance

DEPARTMENT: Planning

PUBLIC HEARING: YES

ATTACHMENT: Yes
PAGES: 2

INFORMATION CONTACT: Andrew Baker
Planning Director
PHONE NUMBER: 404-687-7154

Deferred 2/28/17

PURPOSE: To expressly prohibit loitering in front of alcohol outlets, gas stations, and convenience stores.

NEED/IMPACT: To allow the board of commissioners to consider whether to amend Chapter 16 of the DeKalb County Code of Ordinances to include a prohibition on loitering in front of alcohol outlets, gas stations, and convenience stores.

RECOMMENDATION(S): To adopt the attached ordinance on February 28, 2017. 0 89A

FOR USE BY COMMISSION OFFICE/CLERK ONLY

ACTION : 2017-03-28 Item14

MOTION was made by Mereda Davis Johnson, seconded by Jeff Rader and passed 7-0-0-0 to defer for 30 days until April 25, 2017, to adopt an ordinance to expressly prohibit loitering in front of alcohol outlets, gas stations, and convenience stores.

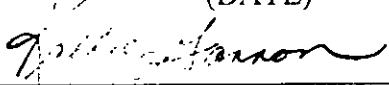
ADOPTED: MAR 28 2017
(DATE)

PRESIDING OFFICER
DEKALB COUNTY BOARD OF
COMMISSIONERS

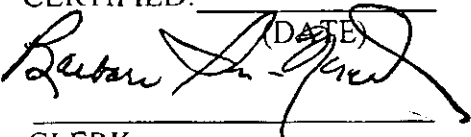
CERTIFIED: MAR 28 2017
(DATE)

CLERK,
DEKALB COUNTY BOARD
OF COMMISSIONERS

FOR USE BY CHIEF EXECUTIVE OFFICER ONLY

APPROVED: APR 05 2017
(DATE)

CHIEF EXECUTIVE OFFICER
DEKALB COUNTY

VETOED: _____
(DATE)

CHIEF EXECUTIVE OFFICER
DEKALB COUNTY

VETO STATEMENT ATTACHED: _____

MINUTES:

FOR : Kathie Gannon, Steve Bradshaw, Gregory Adams, Nancy Jester, Larry Johnson, Mereda Davis Johnson, Jeff Rader

AGAINST : None

ABSTAIN : None

ABSENT : None

AN ORDINANCE

**AN ORDINANCE TO AMEND CHAPTER 16 OF
THE CODE OF DEKALB COUNTY, GEORGIA,
AND FOR OTHER PURPOSES.**

WHEREAS, the Governing Authority of DeKalb County is tasked with the protection of the County's health, safety, and general welfare; and

WHEREAS, loitering near alcohol outlets, automobile gas stations, and convenience stores is associated with increased criminal activity;

NOW THEREFORE, BE IT ORDAINED by the Governing Authority of DeKalb County, Georgia, and it is hereby ordained by the authority of same, that 16 of the Code of DeKalb County, as Revised 1988, is hereby amended as follows:

PART I. ENACTMENT

By of Chapter 16 Section 43(a) of the Code of DeKalb County as Revised 1988, to read as follows:



Sec. 16-43. Loitering—Generally.

(a) It shall be unlawful for any person after having been directed by an officer or member of the police department to move away therefrom, to remain or loiter in front of any church or other place of public worship during services therein, or in front of any theater, concert hall, ballroom, coffeehouse, tavern, alcohol outlet, gas station, convenience store, or other public place, or to loiter or idle away time around the hotels or on the sidewalks or public streets or roads of the county.

PART II. EFFECTIVE DATE

This ordinance shall become effective immediately on the date of adoption by the board of commissioners and approval by the chief executive officer.

PART III. SEVERABILITY

Should any section or provision of this ordinance be declared by a court of competent jurisdiction to be invalid or unconstitutional, such decision shall not affect the validity of the ordinance as a whole nor any part thereof other than the part so declared to be invalid or unconstitutional. All ordinances or resolutions, or parts thereof, in conflict with this ordinance are repealed.

ADOPTED by the DeKalb County Board of Commissioners, this ____ day of _____, 2017.

KATHIE GANNON
Presiding Officer
Board of Commissioners
DeKalb County, Georgia

APPROVED by the Chief Executive Officer of DeKalb County, this ____ day of _____, 2017.

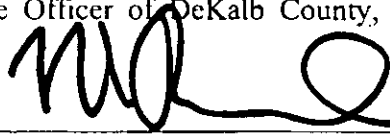
MICHAEL THURMOND
Chief Executive Officer
DeKalb County, Georgia

ATTEST:

BARBARA NORWOOD-SANDERS, CCC
Clerk to the Board of Commissioners
And Chief Executive Officer
DeKalb County, Georgia

APPROVED AS TO FORM:

APPROVED AS TO SUBSTANCE:

O.V. BRANTLEY
County Attorney
DeKalb County, Georgia

ANDREW BAKER
Planning Director
DeKalb County, Georgia

DEKALB COUNTY

ITEM NO. 15

PLANNING COMMISSION

HEARING TYPE
Action

BUSINESS AGENDA / MINUTES

MEETING DATE: March 28, 2017

ACTION TYPE
Resolution

SUBJECT: Right-of-way reduction request for a portion of Rockbridge Road, Old Rockbridge Road and 3rd Avenue in the Scottdale Area Overlay District within the proposed new Rockland Terrace Subdivision.

COMMISSION DISTRICTS: Districts 4 and 6

DEPARTMENT: Planning & Sustainability

PUBLIC HEARING: YES NO X

ATTACHMENT: YES NO
PAGES: 5

INFORMATION CONTACT: PHONE NUMBER: Andrew Baker and Marian Eisenberg 404 371 2155

Deferred 12/13/16, 1/24/17, 2/14/17, 2/28/17

PURPOSE:

To consider approving a waiver to the required right-of-way widths of public streets adjoining the perimeter of the proposed 56 lot Rockbridge Subdivision. The waiver request pertains to a portion of Rockbridge Rd, between Old Rockbridge Road and 3rd Avenue. The waiver is to reduce right-of-way of **Rockbridge, a minor arterial from 80 feet required to 60 feet proposed.** The portion of **Old Rockbridge Road** between Rockbridge Road and 3rd Avenue request to waiver is **from 70 feet to 50 feet.** The portion of **3rd Avenue** between Rockbridge Road and Old Rockbridge Road request to waiver is from **55 feet to 50 feet.**

NEED IMPACT:

The Sketch Plat (Preliminary Plan) was approved for 56 lots along the subject streets. Access to the lots is rear accessed from an internal alley system extending from the subject streets. The proposed subdivision plat and right-of-ways are attached. The applicant states in the letter of request "The residential use of the property is not being changed. The property is currently zoned R-75, and was developed with 18 homes on over 16 acres of land. The right of-way will be improved by the Developer with the widening of the paved driving area, and the installation of sidewalks along the frontage of the property. Therefore, the residential character of the area will remain intact."

Per DeKalb County Code (14-191 e.2.) the following should be considered in a request to waive or modify road improvements:

- A. Existing use of property not to be substantially changed (i.e. traffic generation and ingress/egress would remain the same).
- B. Governmental construction plans for the road indicate a pavement width less than county standards (only the planned pavement width shall be required);
- C. No more than 5 percent of average daily traffic generation would occur between 7:00 A.M. and 9:00 A.M. and 4:00 P.M. and 6:00 P.M. on weekdays;
- D. The existing road meets current county standards; or
- E. Widening would create a hazard to traffic, pedestrians, or bicyclists along the thoroughfare.

RECOMMENDATION:

APPROVAL. Existing use of property not substantially changed.

FOR USE BY COMMISSION OFFICE/CLERK ONLY

ACTION : 2017-03-28 Item15

MOTION was made by Steve Bradshaw, seconded by Jeff Rader and passed 7-0-0-0 to **withdraw** the consideration of Existing use of property not substantially changed, in the request to waive or modify road improvements, for the Right-of-Way reduction request for a portion of Rockbridge Road, Old Rockbridge Road and 3rd Avenue in the Scottdale Area Overlay District within the proposed new Rockland Terrace Subdivision.

ADOPTED: MAR 28 2017

(DATE)

PRESIDING OFFICER
DEKALB COUNTY BOARD OF
COMMISSIONERS

CERTIFIED: MAR 28 2017

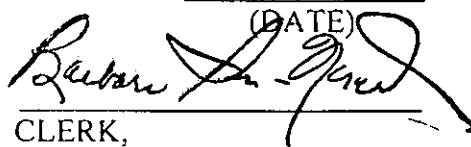
(DATE)

CLERK,
DEKALB COUNTY BOARD
OF COMMISSIONERS

FOR USE BY CHIEF EXECUTIVE OFFICER ONLY

APPROVED: APR 05 2017
(DATE)

CHIEF EXECUTIVE OFFICER
DEKALB COUNTY

VETOED: _____
(DATE)

CHIEF EXECUTIVE OFFICER
DEKALB COUNTY

VETO STATEMENT ATTACHED: _____

MINUTES:

FOR : Kathie Gannon, Steve Bradshaw, Gregory Adams, Nancy Jester, Larry Johnson, Mereda Davis Johnson, Jeff Rader

AGAINST : None

ABSTAIN : None

ABSENT : None

October 6, 2016

VIA E-MAIL (aabaker@dekalbcountyga.gov)

Andrew Baker, Director
DeKalb County Planning and Sustainability
330 W. Ponce de Leon Ave., 5th Floor
Decatur, GA 30030

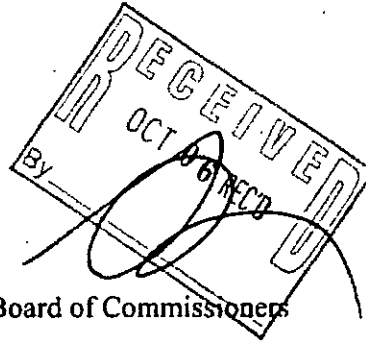

Re: Request for Right of Way Waiver by Board of Commissioners

Dear Mr. Baker:

On behalf of my client, Rockbridge Residential Holdings, LLC (the "Developer"), I am hereby requesting the initiation of a Right of Way Waiver request to the DeKalb County Board of Commissioner from Chapter 14, Section 191 of the DeKalb County Land Development Code. As set forth in Section 14-191 (e), the Board of Commissioners may authorize deviations for the right of way dedication requirements set forth in Section 14-191 (b) if any one of the following is found:

- a. Existing use of property is not to be substantially changed as a result of proposed development or construction;
- b. Existing government construction plans for the roadway indicate lesser right-of-way would be required for dedication; or
- c. The adjoining frontage is developed and the predominate existing right-of-way meets county standards.

The Developer is seeking to develop a 56 unit subdivision bounded by Rockbridge Road, Old Rockbridge Road and 3rd Avenue within Tier IV of the Scottdale Overlay District. The Sketch Plat for the proposed subdivision was approved by the Planning Commission in July of 2016. During the Land Development Permit review, the Transportation Department advised the Developer that Rockbridge Road has been designated as a minor arteria road requiring an increase of the existing 40 foot right of way to 80 feet. Additionally, Old Rockbridge Road which is also an existing 40 foot right of way, is now designated as a Collector Street, which requires an increase to 70 feet, and finally 3rd Avenue which is an existing 30 foot right of way, is considered to be a local street requiring an increase to 55 feet. For reasons not yet determined, this information was not given to the Developer during the Sketch Plat process having the lot yield was determined.

The designation of both Rockbridge Road and Old Rockbridge Road is startling in light of the residential character of the area. There can be no questions that requiring a 20 foot widening of Rockbridge Road from the existing center line on both side of the street in some locations, and a 15 foot widening of Old Rockbridge Road will have a dramatic effect on the aesthetic feel of this neighborhood. Additionally, the road



Page 2

widening will push the homes further back from the road way which will also negatively impact the aesthetics of Tier IV of the Scottsdale neighborhood.

As the development of the 56 unit subdivision will include the recreation of the street grid pattern within Tier IV and allow for the development of pocket parks and rear alley entrances off of the side roads being created, it is the Developer's assertion that a significant widening of Rockbridge Road, Old Rockbridge Road and 3rd Avenue is undesirable, and unnecessary for the following reasons:

1. The residential use of the property is not being changed. The property is currently zoned R-75, and was developed with 18 homes on over 16 acres of land. The right of way will be improved by the Developer with the widening of the paved driving area, and the installation of sidewalks along the frontage of the project. Therefore, the residential character of the area will remain intact.
2. Based upon conversation with the County's Transportation Department there currently are no plans to widen the entirety of Rockbridge Road and Old Rockbridge Road to 80ft. and 70ft, and 3rd Avenue to 55ft, and based upon comments received from the community, there is no desire to see the roads significantly widened within Tier IV of the Overlay District due to concerns about the impact that it will have on the character of the area.

Based upon the foregoing, the Developer is hereby requesting the following Right of Way Dedication Modification:

1. Reduce required dedication along Rockbridge Road from 40 feet from center line to 30 feet from center line;
2. Reduce required dedication along Old Rockbridge Road from 35 feet from center line to 25 feet from center line; and
3. Reduce required dedication along 3rd Avenue from 27.5 feet from center line to 25 feet from center line.

Submitted with this request are three (3) copies of the survey showing the existing improvements, and the proposed site plan for the subdivision showing the proposed right of way modifications, along with the street improvements. Please contact me should you need any additional information.

Sincerely,

Michèle L. Battle

cc: Patrece Keeter (via email)
 Commissioner Sharon Barnes Sutton (via email)
 Commissioner Kathie Gannon (via email)

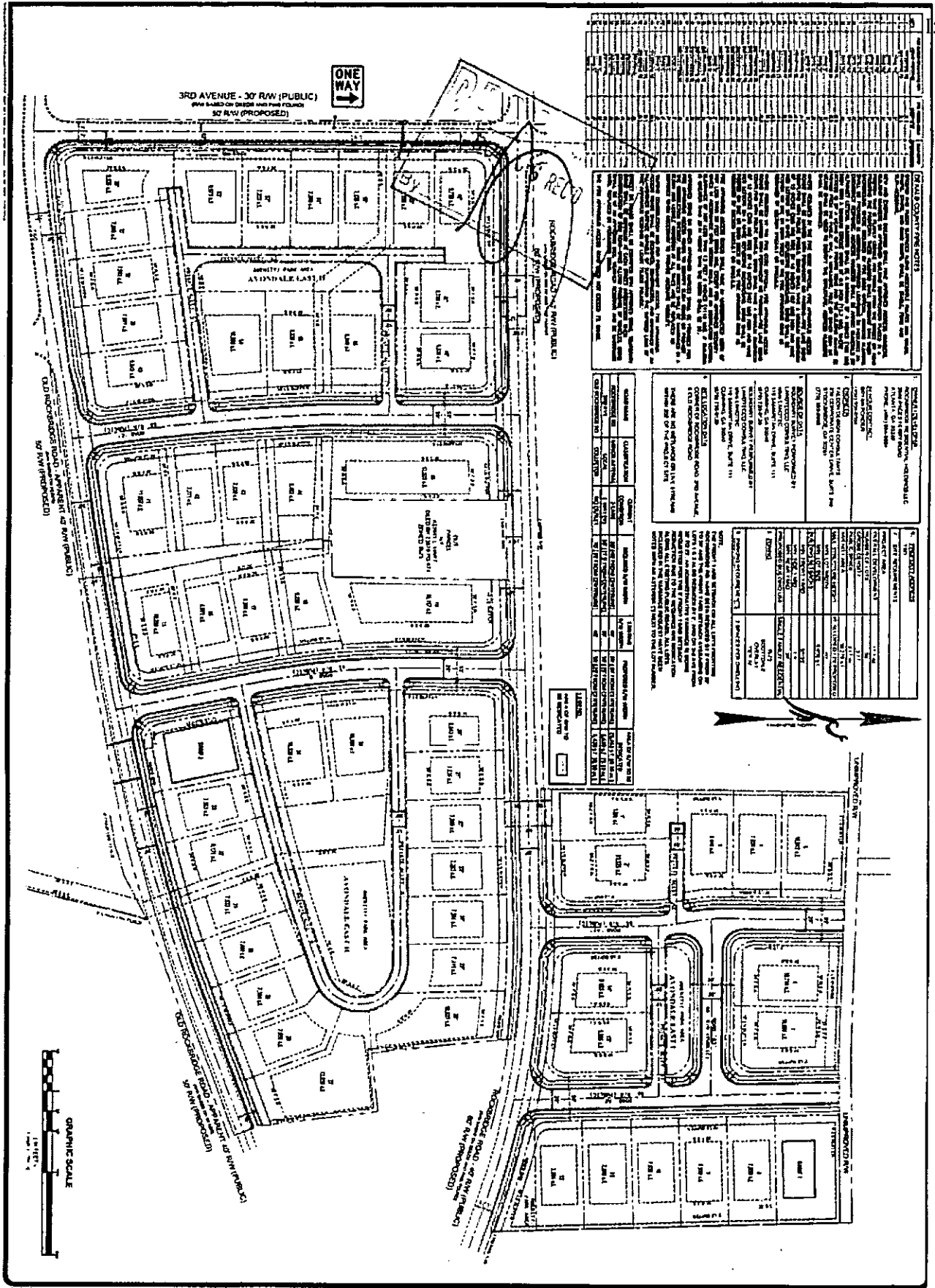

PLANNING & CONSTRUCTION SERVICES
 1000 Peachtree Street, N.E., Suite 1000
 Atlanta, Georgia 30309
 Phone: (404) 525-1000
 Fax: (404) 525-1001
 Website: www.pcservices.com

AVONDALE EAST I AND II
 1000 Peachtree Street, N.E., Suite 1000
 Atlanta, Georgia 30309
 Phone: (404) 525-1000
 Fax: (404) 525-1001
 Website: www.pcservices.com

NO.	DATE	DESCRIPTION
1	11/11/11	ISSUED FOR PERMIT
2	11/11/11	ISSUED FOR PERMIT
3	11/11/11	ISSUED FOR PERMIT
4	11/11/11	ISSUED FOR PERMIT
5	11/11/11	ISSUED FOR PERMIT
6	11/11/11	ISSUED FOR PERMIT
7	11/11/11	ISSUED FOR PERMIT
8	11/11/11	ISSUED FOR PERMIT
9	11/11/11	ISSUED FOR PERMIT
10	11/11/11	ISSUED FOR PERMIT
11	11/11/11	ISSUED FOR PERMIT
12	11/11/11	ISSUED FOR PERMIT
13	11/11/11	ISSUED FOR PERMIT
14	11/11/11	ISSUED FOR PERMIT
15	11/11/11	ISSUED FOR PERMIT
16	11/11/11	ISSUED FOR PERMIT
17	11/11/11	ISSUED FOR PERMIT
18	11/11/11	ISSUED FOR PERMIT
19	11/11/11	ISSUED FOR PERMIT
20	11/11/11	ISSUED FOR PERMIT
21	11/11/11	ISSUED FOR PERMIT
22	11/11/11	ISSUED FOR PERMIT
23	11/11/11	ISSUED FOR PERMIT
24	11/11/11	ISSUED FOR PERMIT
25	11/11/11	ISSUED FOR PERMIT
26	11/11/11	ISSUED FOR PERMIT
27	11/11/11	ISSUED FOR PERMIT
28	11/11/11	ISSUED FOR PERMIT
29	11/11/11	ISSUED FOR PERMIT
30	11/11/11	ISSUED FOR PERMIT
31	11/11/11	ISSUED FOR PERMIT
32	11/11/11	ISSUED FOR PERMIT
33	11/11/11	ISSUED FOR PERMIT
34	11/11/11	ISSUED FOR PERMIT
35	11/11/11	ISSUED FOR PERMIT
36	11/11/11	ISSUED FOR PERMIT
37	11/11/11	ISSUED FOR PERMIT
38	11/11/11	ISSUED FOR PERMIT
39	11/11/11	ISSUED FOR PERMIT
40	11/11/11	ISSUED FOR PERMIT
41	11/11/11	ISSUED FOR PERMIT
42	11/11/11	ISSUED FOR PERMIT
43	11/11/11	ISSUED FOR PERMIT
44	11/11/11	ISSUED FOR PERMIT
45	11/11/11	ISSUED FOR PERMIT
46	11/11/11	ISSUED FOR PERMIT
47	11/11/11	ISSUED FOR PERMIT
48	11/11/11	ISSUED FOR PERMIT
49	11/11/11	ISSUED FOR PERMIT
50	11/11/11	ISSUED FOR PERMIT
51	11/11/11	ISSUED FOR PERMIT
52	11/11/11	ISSUED FOR PERMIT
53	11/11/11	ISSUED FOR PERMIT
54	11/11/11	ISSUED FOR PERMIT
55	11/11/11	ISSUED FOR PERMIT
56	11/11/11	ISSUED FOR PERMIT
57	11/11/11	ISSUED FOR PERMIT
58	11/11/11	ISSUED FOR PERMIT
59	11/11/11	ISSUED FOR PERMIT
60	11/11/11	ISSUED FOR PERMIT
61	11/11/11	ISSUED FOR PERMIT
62	11/11/11	ISSUED FOR PERMIT
63	11/11/11	ISSUED FOR PERMIT
64	11/11/11	ISSUED FOR PERMIT
65	11/11/11	ISSUED FOR PERMIT
66	11/11/11	ISSUED FOR PERMIT
67	11/11/11	ISSUED FOR PERMIT
68	11/11/11	ISSUED FOR PERMIT
69	11/11/11	ISSUED FOR PERMIT
70	11/11/11	ISSUED FOR PERMIT
71	11/11/11	ISSUED FOR PERMIT
72	11/11/11	ISSUED FOR PERMIT
73	11/11/11	ISSUED FOR PERMIT
74	11/11/11	ISSUED FOR PERMIT
75	11/11/11	ISSUED FOR PERMIT
76	11/11/11	ISSUED FOR PERMIT
77	11/11/11	ISSUED FOR PERMIT
78	11/11/11	ISSUED FOR PERMIT
79	11/11/11	ISSUED FOR PERMIT
80	11/11/11	ISSUED FOR PERMIT
81	11/11/11	ISSUED FOR PERMIT
82	11/11/11	ISSUED FOR PERMIT
83	11/11/11	ISSUED FOR PERMIT
84	11/11/11	ISSUED FOR PERMIT
85	11/11/11	ISSUED FOR PERMIT
86	11/11/11	ISSUED FOR PERMIT
87	11/11/11	ISSUED FOR PERMIT
88	11/11/11	ISSUED FOR PERMIT
89	11/11/11	ISSUED FOR PERMIT
90	11/11/11	ISSUED FOR PERMIT
91	11/11/11	ISSUED FOR PERMIT
92	11/11/11	ISSUED FOR PERMIT
93	11/11/11	ISSUED FOR PERMIT
94	11/11/11	ISSUED FOR PERMIT
95	11/11/11	ISSUED FOR PERMIT
96	11/11/11	ISSUED FOR PERMIT
97	11/11/11	ISSUED FOR PERMIT
98	11/11/11	ISSUED FOR PERMIT
99	11/11/11	ISSUED FOR PERMIT
100	11/11/11	ISSUED FOR PERMIT

GRAPHIC SCALE
1" = 100'

REVISIONS

NO.	DATE	DESCRIPTION
1	11/11/11	ISSUED FOR PERMIT

RIGHT-OF-WAY DEDICATION VARIANCE EXHIBIT
 FOR
**AVONDALE EAST I
 AVONDALE EAST II**
 LOCATED IN
 DEKALB COUNTY, GEORGIA
 LAND LOT 10, 16th DISTRICT

Sec. 14-191. Improvements, right-of-way dedication.

(1) Right-of-way dedication may be waived or modified if:

- a. Existing use of property is not to be substantially changed as a result of proposed development or construction;
- b. Existing government construction plans for the roadway indicate lesser right-of-way would be required for dedication; or
- c. The adjoining frontage is developed and the predominate existing right-of-way meets county standards.

(2) Road improvements may be waived or modified if:

- a. Existing use of property not to be substantially changed (i.e., traffic generation and ingress/egress would remain the same);
- b. Governmental construction plans for the road indicate a pavement width less than county standards (only the planned pavement width shall be required);
- c. No more than five (5) percent of average daily traffic generation would occur between 7:00 a.m. and 9:00 a.m. and 4:00 p.m. and 6:00 p.m., on weekdays;
- d. The existing road meets current county standards; or
- e. Widening would create a hazard to traffic, pedestrians, or bicyclists along the thoroughfare.

(3) The applicant may, with written concurrence of the development director and the county attorney, provide payment to the county in lieu of road improvements when:

- a. Road improvements by state or local action are scheduled within twenty-four (24) months;
- b. Existing utility companies' improvements are situated so as to require their removal or relocation before road improvements should be accomplished;
- c. Improvements would be economically unfeasible or would cause unreasonable land development hardships because of topography, soils, bridges, grades, etc., and delay of improvements would not adversely impact the county's road system; and
- d. Payment for road improvements shall be in accordance with a schedule adopted by the board of commissioners in January of each year and based on current street construction costs for the required section.

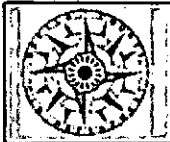
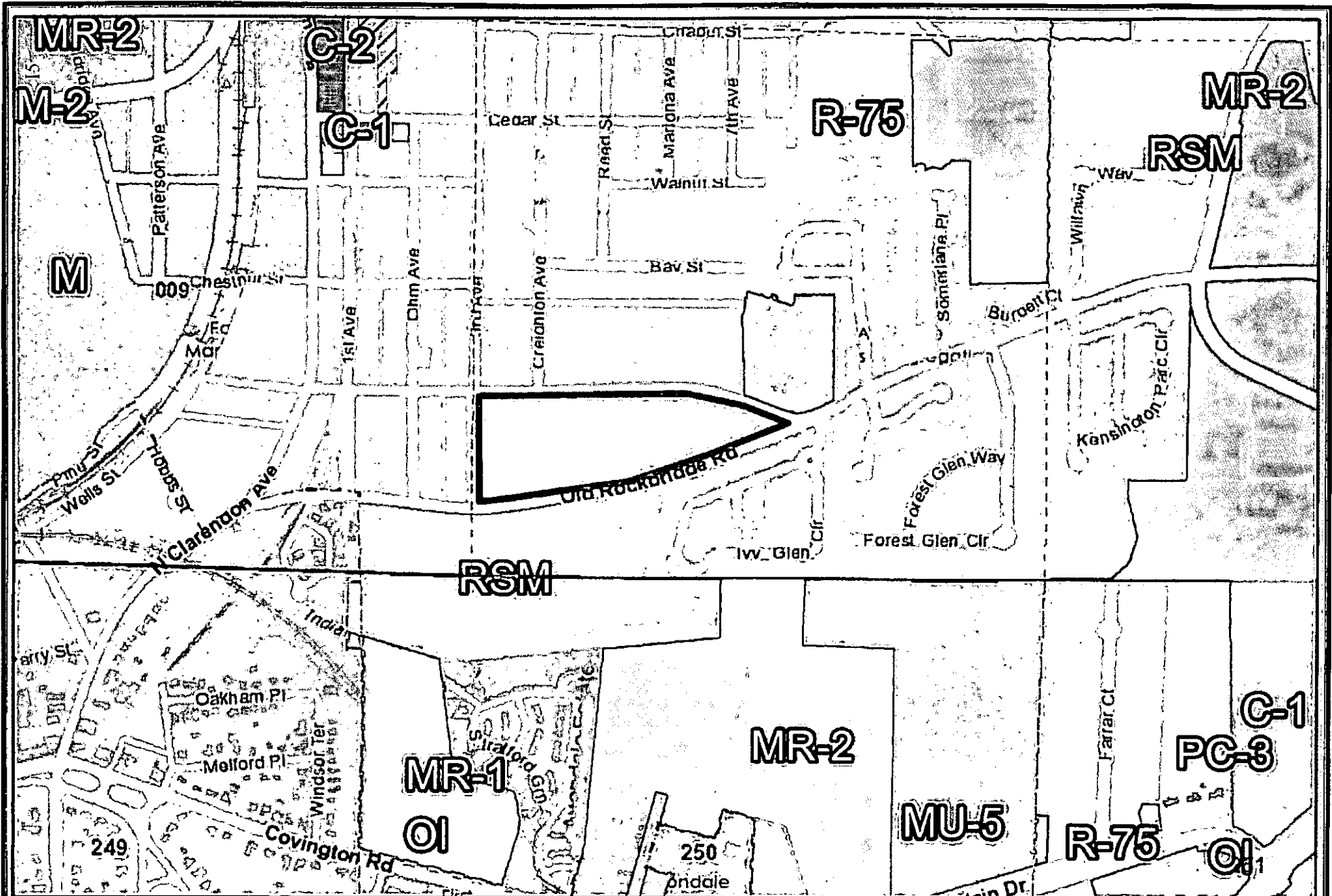

DeKalb County Parcel Map



Date Printed: 11/29/2016



DeKalb County GIS Disclaimer:
 The maps and data contained on DeKalb County's Geographic Information System (GIS) are subject to constant change. While DeKalb County strives to provide accurate and up-to-date information, the information is provided "as is" without warranty, representation or guarantee of any kind as to the content, sequence, accuracy, timeliness or completeness of any of the database information provided herein. DeKalb County explicitly disclaims all representations and warranties, including, without limitation, the implied warranties of merchantability and fitness for a particular purpose. In no event shall DeKalb County be liable for any special, indirect, or consequential damages whatsoever resulting from loss of use, data, or profits, whether in an action of contract, negligence, or other actions, arising out of or in connection with the use of the maps and/or data herein provided. The maps and data are for illustration purposes only and should not be relied upon for any reason. The maps and data are not suitable for site-specific decision-making nor should it be construed or used as a legal description. The areas depicted by maps and data are approximate, and are not necessarily accurate to surveying or engineering standards.

DEKALB COUNTY

ITEM NO. 16

BOARD OF COMMISSIONERS

BUSINESS AGENDA / MINUTES

MEETING DATE: March 28, 2017

HEARING TYPE
Action

ACTION TYPE
Resolution

SUBJECT: LED Conversion of Georgia Power Post Top Lights
Commission Districts - Countywide

DEPARTMENT: Public Works - Transportation

PUBLIC HEARING: YES NO

ATTACHMENT: YES No

PAGES: 3

INFORMATION CONTACT: David Pelton
7705 # 9 RRM
PHONE NUMBER: 770-492-5206

Deferred 2/28/17

PURPOSE:

To consider authorizing the conversion of 5216 existing post top street lights in unincorporated DeKalb County to a LED fixture; and
To consider authorizing the Chief Executive Officer to execute the necessary documents pertaining to this project.

NEED/IMPACT:

Most of the street lights within Georgia Power's service area in unincorporated DeKalb County have been converted to more efficient LED lights. This item will authorize the conversion of existing post top lights to a more efficient LED fixture. This will result in an increase in the monthly charge for electricity and maintenance fee for these lights from \$80,629.78 to \$82,526.76. It is anticipated that these rates will be reduced at some point in the future to reflect the reduced energy use after Georgia Power has recouped the upfront capital costs. Rates for these lights are set by the Georgia Public Service Commission. These will be 3000k lights and not the whiter 4000k lights used in the first phase of the conversion.

RECOMMENDATION(S):

Authorize the conversion of 5216 existing post top street lights in unincorporated DeKalb County to a LED fixture, and
Authorize the Chief Executive Officer to execute the necessary documents pertaining to this project.

FOR USE BY COMMISSION OFFICE/CLERK ONLY

ACTION : 2017-03-28 Item16

MOTION was made by Gregory Adams, seconded by Steve Bradshaw and passed 7-0-0-0 to defer to the next meeting until April 11, 2017, to Authorize the conversion of 5216 existing post top street lights in unincorporated DeKalb County to a LED fixture; and Authorize the Chief Executive Officer to execute the necessary documents pertaining to this project.

ADOPTED: MAR 28 2017
(DATE)



PRESIDING OFFICER
DEKALB COUNTY BOARD OF
COMMISSIONERS

CERTIFIED: MAR 28 2017
(DATE)



CLERK,
DEKALB COUNTY BOARD
OF COMMISSIONERS

FOR USE BY CHIEF EXECUTIVE OFFICER ONLY

APPROVED: APR 05 2017
(DATE)

CHIEF EXECUTIVE OFFICER
DEKALB COUNTY

VETOED: _____
(DATE)

CHIEF EXECUTIVE OFFICER
DEKALB COUNTY

VETO STATEMENT ATTACHED: _____

MINUTES:

- FOR : Kathie Gannon, Steve Bradshaw, Gregory Adams, Nancy Jester, Larry Johnson, Mereda Davis Johnson, Jeff Rader
- AGAINST : None
- ABSTAIN : None
- ABSENT : None

Governmental Regulated LED Roadway Lights Authorization



Customer Legal Name DeKalb County Government DBA N/A

Service Address Roadway Lighting County DeKalb

Mailing Address Fifth Floor 1300 Commerce Dr. Decatur Ga. 30030

Email N/A Tel # _____ Alt Tel _____

Tax ID Same _____ Business Description City/County Government

Existing Customer Yes No If Yes, the current Account Number _____ Note: LED Roadway lights must be set up on a separate account

Equipment (excludes any applicable sales taxes)

Action	Qty.	Lumens	M (TOU) / UM	Type	Description	Estimated Monthly Regulated Charge
(1) INS	1,012	4,000	UM	RW	LED Post Top Fixture @ \$11.80	\$11,941.60
(2) INS	4,204	6,000	UM	RW	LED Post Top Fixture @ \$16.79	\$70,585.16
(3)						
(4)						
(5)						

Install (INS) (M)(TOU) - Roadway (RW)
 Removal (REM) Metered Time of Use (UM) - Unmetered Post Top (PT) Wall Pack (WP)

Estimated Total

\$82,526.76

Project Notes:

00033-69202 00033-69300

00034-11907 00034-04206

00033-59500 00033-89900

2 of 2 Documents

The estimated monthly regulated charge is based on Georgia Public Service Commission (PSC) approved tariffs in place at the signing of this document. Customer understands that actual usage and future PSC approved tariff changes could change the estimated total. Customer agrees billing is based upon the number of lights attached to the service point(s).

Customer Authorized Signature	Date	Georgia Power Company	Date
Print Name _____	_____	Print Name Jerry Cook	_____
Print _____	_____	Print Account Executive	_____
Title _____	_____	Title _____	_____

GPC Internal Use Only	INS/REM	LN/REG/BEG	LED	REPL	PPID#
DWE _____	_____	R	LED	Repl	_____
DWE _____	_____	R	LED	Repl	Rev Class: Street & Hwy <input type="checkbox"/> Other <input type="checkbox"/>
DWE _____	_____	R	LED	Repl	Region _____
DWE _____	_____	R	LED	Repl	Construction: Existing <input type="checkbox"/> Other <input type="checkbox"/>
DWE _____	_____	R	LED	Repl	_____

If an existing customer, list account number if it is not shown above:

Governmental Regulated LED Roadway Lights Authorization



Customer Legal Name DeKalb County Government DBA N/A

Service Address Roadway Lighting County DeKalb

Mailing Address Fifth Floor 1300 Commerce Dr. Decatur Ga 30030

Email N/A Tel # _____ Alt Tel _____

Tax ID Same _____ Business Description City/County Government

Existing Customer Yes No If Yes, the current Account Number _____

Note: LED Roadway lights must be set up on a separate account

Equipment (excludes any applicable sales taxes)						
Action	Qty.	Lumens	M (TOU) / UM	Type	Description	Estimated Monthly Regulated Charge
(1) REM	882		UM	HPS	100 Watt Post Top Fixtures@ \$11.32	-\$9,984.24
(2) REM	4,204		UM	HPS	150 Watt Post Top Fixtures@ \$16.36	-\$68,777.44
(3) REM	130		UM	MV	175 Watt Post Top Fixtures@ \$14.37	-\$1,868.10
(4)						
(5)						
Estimated Total						-\$80,629.78

Install (INS) _____ (M)(TOU) - Roadway (RW)
 Removal (REM) _____ Metered Time of Use Post Top (PT)
 (UM) - Wall Pack (WP)
 Unmetered _____

Project Notes:	
00033-69202	00033-69300
00034-11907	00034-04206
00033-59500	00033-89900
1 of 2 Documents	

The estimated monthly regulated charge is based on Georgia Public Service Commission (PSC) approved tariffs in place at the signing of this document. Customer understands that actual usage and future PSC approved tariff changes could change the estimated total. Customer agrees billing is based upon the number of lights attached to the service point(s).

Customer Authorized Signature	Date	Georgia Power Company	Date
Print Name _____	_____	Print Name Jerry Cook	_____
Print Title _____	_____	Print Account Executive	_____

GPC Internal Use Only	INS/REM	UNREG/REG	LED/LED	BETRY/NEW/RWC	
DWE _____	_____	R	LED	Repl	PPID# _____
DWE _____	_____	R	LED	Repl	Rev Class: Street & Hwy <input type="checkbox"/> Other <input type="checkbox"/>
DWE _____	_____	R	LED	Repl	Region _____
DWE _____	_____	R	LED	Repl	Construction: Existing <input type="checkbox"/> Other <input type="checkbox"/>
DWE _____	_____	R	LED	Repl	

If an existing customer, list account number if it is not shown above:

DESCRIPTION

The Traditionaire LED outdoor luminaire displays the old-fashioned charm of traditional area lighting, enhancing any setting with distinctive styling. As a decorative luminaire, the Traditionaire LED tastefully complements the architectural and environmental design of parks and roadways. The high-lumen downlight configuration uses Eaton's patented LightBAR™ technology to deliver uniform and efficient illumination to pedestrian and roadway applications.

Catalog #		Type	
Project		Date	
Comments			
Prepared by			

SPECIFICATION FEATURES

Construction
Hinged (stainless steel hinge pins) die-cast aluminum housing and cover with cupola. 3G vibration tested to ensure strength of construction and longevity in application.

Optics
Choice of six patented, high-efficiency AccuLED Optic™ technology manufactured from injection-molded acrylic. Optics are precisely designed to shape the light output, maximizing efficiency and application spacing. AccuLED Optic technology, creates consistent distributions with the scalability to meet customized application requirements. Offered Standard in 4000K (+/- 275K) CCT and minimum 70 CRI. Optional 3000K CCT, 5000K CCT and 5700K CCT. For the ultimate level of spill

light control, an optional house-side shield accessory can be field or factory installed. The house-side shield is designed to seamlessly integrate with the SL2 or SL3 optics.

Electrical
LED drivers mount to die-cast aluminum back housing for optimal heat sinking, operation efficacy, and prolonged life. Standard drivers feature electronic universal voltage (120-277V 50/60Hz), 347V 60Hz or 480V 60Hz operation, greater than 0.9 power factor, less than 20% harmonic distortion, and is suitable for operation in -40°C to 40°C ambient environments. All fixtures are shipped standard with 10kV/10kA common - and differential - mode surge protection. LightBARs feature an IP66 enclosure rating and

maintain greater than 95% lumen maintenance at 60,000 hours per IESNA TM-21.

Mounting
Self-aligning pole-top fitter for 3" O.D. pole tops or vertical tenons. Square headed 1-1/4" polymer coated mounting bolts with a lock nut.

Finish
Cast components finished in a super durable black TGIC polyester powder coat paint, 2.5 mil nominal thickness for superior protection against fade and wear. Optional colors include: bronze, grey and white. RAL and custom color matches available.

Warranty
Five-year warranty.



**UTLD
TRADITIONAIRE
LED DOWNLIGHT**

1 - 3 LightBARs
Solid State LED

DECORATIVE POST TOP
LUMINAIRE

DIMENSIONS

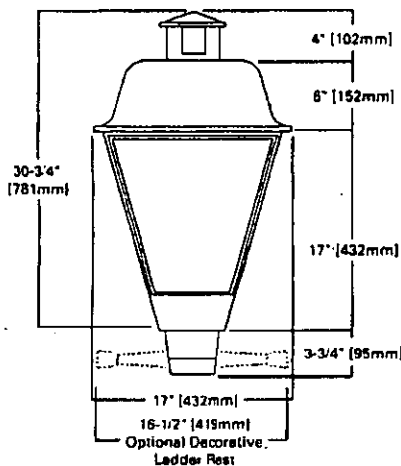

OPTIONAL BIRD CONE

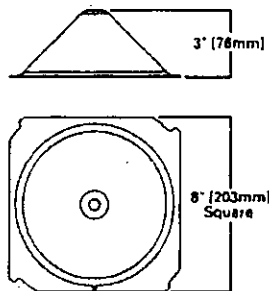

CERTIFICATION DATA

UL/cUL Listed
LM79 / LM80 Compliant
3G Vibration Rated
IP66 LightBARs
ISO 9001

ENERGY DATA

Electronic LED Driver
>0.9 Power Factor
<20% Total Harmonic Distortion
120-277V/50 & 60Hz, 347V/60Hz,
480V/60Hz
-40°C Minimum Temperature
40°C Ambient Temperature Rating

EPA

Effective Projected Area: (Sq. Ft.)
2.3

SHIPPING DATA

Approximate Net Weight:
37 lbs. (17 kgs.)

DEKALB COUNTY

ITEM NO. 17

BOARD OF COMMISSIONERS

HEARING TYPE
Action

BUSINESS AGENDA / MINUTES

ACTION TYPE
Resolution

MEETING DATE: March 28, 2017

SUBSTITUTE

SUBJECT: Georgia Power Lighting Agreement: Clifton Road from North Decatur Road to Haygood Road
Commission Districts - 2, 6

DEPARTMENT: Public Works - Transportation

PUBLIC HEARING: YES NO

ATTACHMENT: YES No
PAGES: 3

INFORMATION CONTACT: David Pelton
770-492-5206

Deferred 2/28/17

PURPOSE:

To consider entering into a non-governmental lease agreement with the Georgia Power Company for street lighting on Clifton Road; and
To consider authorizing the Chief Executive Officer to execute all necessary documents pertaining to this project.

NEED/IMPACT:

As part of the Emory University Hospital redevelopment project, Emory University is required to install decorative LED street lighting within the County right of way, an investment of \$482,156.00 in street lighting infrastructure along Clifton Road between North Decatur Road and Haygood Road. To meet the minimum street lighting standards, it is necessary to install thirty-five 80 watt LED lights and thirty-five 85 watt LED lights. The impact to the Transportation Division's budget will be approximately \$15,850.00 per year.

RECOMMENDATION(S):

To approve entering into a non-governmental lease agreement with the Georgia Power Company for street lighting on Clifton Road; and
To consider authorizing the Chief Executive Officer to execute all necessary documents pertaining to this project.

FOR USE BY COMMISSION OFFICE/CLERK ONLY

ACTION : 2017-03-28 Item 17

MOTION was made by Jeff Rader, seconded by Gregory Adams and passed 7-0-0-0 to **withdraw** the entering into a non-governmental lease agreement with the Georgia Power Company for street lighting on Clifton Road; and to consider authorizing the Chief Executive Officer to execute all necessary documents pertaining to this project.

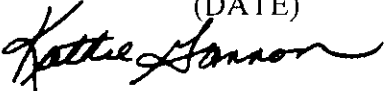
ADOPTED: MAR 28 2017
(DATE)

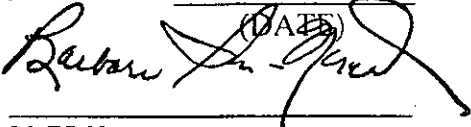
PRESIDING OFFICER
DEKALB COUNTY BOARD OF
COMMISSIONERS

CERTIFIED: MAR 28 2017
(DATE)

CLERK,
DEKALB COUNTY BOARD
OF COMMISSIONERS

FOR USE BY CHIEF EXECUTIVE OFFICER ONLY

APPROVED: APR 05 2017
(DATE)

CHIEF EXECUTIVE OFFICER
DEKALB COUNTY

VETOED: _____
(DATE)
CHIEF EXECUTIVE OFFICER
DEKALB COUNTY

VETO STATEMENT ATTACHED: _____

MINUTES:

FOR : Kathie Gannon, Steve Bradshaw, Gregory Adams, Nancy Jester, Larry Johnson, Mereda Davis Johnson, Jeff Rader

AGAINST : None

ABSTAIN : None

ABSENT : None



Governmental NESC® Lease Agreement Lighting Services

DEKALB CO GOVERNMENT (EMORY CLIFTON ROAD PROJECT)

Customer Legal Name CLIFTON ROAD PROJECT DBA NA
 Service Address 0 CLIFTON ROAD, ATLANTA, GA 30322 County DEKALB
 Mailing Address SAME
 Email NA Tel # 770-465-5397 Alt Tel NA
 Tax ID NA Business Description GOVERNMENTAL
 Existing Customer Yes No If Yes (and if possible), does Customer want Equipment added to an existing account? Yes No If Yes, Which Account Number _____

Equipment (excludes any applicable sales taxes)										
Action	Qty	Wattage	Type	Description	OH/UG	M/UM	Equipment Amount (\$)	Estimated Regulated Charge (\$)*	Estimated Monthly Charge (\$)*	
(1)	INS	35	80	LED	GRANVILLE POST TOPS	UG	UM	\$566.30	\$93.80	\$660.10
(2)	INS	35	85	LED	TEAR DROP FIXTURES	UG	UM	\$560.00	\$100.10	\$660.10
(3)										
(4)										
(5)										
Install (INS) Remove (REM) Reconnect (RVC) Previously UnBilled (UNB)							Monthly Total *	\$1,126.30	\$193.90	\$1,320.20

* The Regulated Charge is subject to change at any time as dictated by the Georgia Public Service Commission. The amount shown is an estimate based on Summer rates in effect at time of Agreement proposal; actual charges may vary.

Project Notes: DEVELOPER HAS PAID UPFRONT COST

Initial Term 1 months Prepaid Amount (excludes any applicable sales taxes) \$482,158.00

Customer agrees to lease the Equipment referenced above from Georgia Power Company on the attached terms and conditions and authorizes all actions noted above.
 Customer also agrees to allow removal of existing outdoor lights as outlined in the removal contract incorporated by this reference. Yes N/A

Customer Authorized Signature	Date	Georgia Power Company	Date
Print Name		Print Name	
Print Title		Print Title	

GPC Internal Use Only	REL/REG	UNREG	LED	NEW	REV. CLASS	REV. COST	Lead #	PPID#
DWE _____	INS	UNREG	LED	NEW	No	No	_____	311185110
DWE _____	---	---	---	---	---	---	Rev Class: Com <input checked="" type="checkbox"/> Res <input type="checkbox"/> Ind <input type="checkbox"/>	
DWE _____	---	---	---	---	---	---	Region <u>M. EAST</u>	
DWE _____	---	---	---	---	---	---	Construction: New <input checked="" type="checkbox"/> Existing <input type="checkbox"/>	
DWE _____	---	---	---	---	---	---	Customer Choice? Yes <input type="checkbox"/> No <input checked="" type="checkbox"/>	

If an existing customer, list account number if it is not shown above:

TERMS and CONDITIONS (Governmental NESG)

1. **Leasible Equipment Lease.** This Lease Agreement ("Agreement") states the agreed terms and conditions upon which Georgia Power Company ("GPC") will lease to "Customer" (identified on Page 1) the "Equipment" referenced on Page 1 for use at the stated "Service Address" (the "Premises"); and (B) provide electric service to operate the Equipment. The "Equipment" includes all poles, bases, wiring, conduit, fuses, controls, and related items necessary to provide lighting services through the listed fixtures, unless expressly noted otherwise in "Project Notes." Customer acknowledges that regulatory change during the Agreement term may require GPC to modify or replace some Equipment.
2. **Interest and Title.** This Agreement is not a sale of the Equipment to Customer. Customer expressly acknowledges that GPC retains title to the Equipment and agrees that this Agreement only gives Customer the right to use the Equipment during the Agreement term, so long as Customer complies with all terms and conditions. Customer acknowledges that the Equipment, although attached to real property, always will remain the exclusive personal property of GPC and that GPC may remove the Equipment when this Agreement ends. Customer authorizes GPC, without further consent or action, to file any UCC financing statement or security agreement relating to the Equipment and agrees that GPC may record those documents. GPC makes no representation or warranty regarding treatment of this transaction by the Internal Revenue Service or the status of this Agreement under any federal or state tax law; Customer enters into this Agreement in sole reliance upon Customer's own advisors.
3. **Term.** The initial Agreement term is stated on Page 1, calculated from the date of the first monthly bill. After the initial term, this Agreement automatically renews on a month-to-month basis until terminated by either party by providing written notice of intent to terminate to the other party at least 30 days before the desired termination date. GPC's address for notice is 1700 Montreal Circle, Tucker, GA 30084-6807; Customer's mailing address is noted on Page 1.
4. **Payments.** GPC will invoice Customer per the terms stated on Page 1, subject to any change in the electric service charge dictated by the Georgia Public Service Commission. Customer agrees to pay the amount billed by the due date (20 days after billing date). Customer acknowledges GPC may require Customer to pay a deposit of up to two times the Estimated Monthly Charge in order to continue service, if applicable. Customer must provide a copy of its Georgia sales tax exemption certificate.
5. **Premises Access.** Customer grants a license and right of access to GPC, and its contractors and representatives, to enter the Premises with vehicles and equipment to: (i) test and connect the Equipment and, if applicable, remove or disconnect existing equipment (collectively, the "Installation"); (ii) inspect, maintain, test, replace, repair, or remove the Equipment; (iii) provide electric service for the Equipment; or (iv) conduct any other Agreement-related activity (items (i) - (iv) collectively, the "GPC Activity"). Customer represents that the individual signing this Agreement on its behalf has authority to do so and that it has express authority from all Premises owners (and any other party with rights in the Premises) to enter into this Agreement and to authorize the GPC Activity. Customer is solely responsible for safety of the Premises and agrees that GPC has no obligation to ensure the safety of the Premises.
6. **Installation.** Customer represents that: (i) the Premises' final grade will vary no more than 6 inches from the grade existing at the time of installation; and (ii) if applicable and required for proper installation, Premises property lines will be clearly marked before installation.
 - A. **Customer Work.** If GPC, upon Customer's request, allows Customer to perform any part of the Installation (including trenching) itself or through a third party, Customer warrants that the work will meet GPC's installation specifications (which GPC will provide to Customer and are incorporated by this reference). Customer is responsible for all reasonable additional costs arising from Customer's non-compliance with GPC's specifications or lack of timely (i.e., 10 days) notice to GPC that GPC's installation activity can commence.
 - B. **Underground Facility Obstruction Not Subject to Dig Law.** Because GPC Activity may require excavation not subject to the Georgia Utility Facility Protection Act (O.C.G.A. §§25-9-1 - 25-9-13) ("Dig Law"), Customer must mark any private utility or facility (e.g., gas, water, sewer line, irrigation facility, low voltage data/communication line) or other underground obstruction at the Premises that is not subject to the Dig Law. If GPC causes or incurs damage due to Customer's failure to mark a private utility or obstruction before GPC commences installation, Customer is responsible for all damages and any resulting delay.
 - C. **Underground Condition.** The estimated charges shown on Page 1 include no allowance for any subsurface rock, wetland, underground stream, buried waste, unstable soil, underground obstruction, archeological artifact, burial ground, threatened or endangered species, hazardous substances, etc. not properly marked or identified ("Unforeseen Condition"). If GPC encounters an Unforeseen Condition, GPC, in its sole discretion, may stop all GPC Activity until Customer either remedies the condition or agrees to reimburse all GPC costs arising from the condition. Customer is responsible for all costs of Equipment modification or change requested by Customer or dictated by an Unforeseen Condition or circumstance outside GPC's control.
7. **Equipment Protection and Damage.** After Installation and throughout this Agreement's term, in the event of any work or digging near the Equipment, Customer (or any person or entity working on Customer's behalf) must: (i) provide notice and locate requests to the Georgia Utilities Protection Center ("GPC") and other utility owners or operators as required by the then current Dig Law; (ii) coordinate with the UPC and all utility facility owners or operators as required by the Dig Law; and (iii) comply with the High-Voltage Safety Act (O.C.G.A. §§48-3-30 - 48-3-40). As between Customer and GPC, Customer is responsible for all damages arising from failure to comply with applicable law or for Equipment damage caused by anyone other than GPC (or a GPC contractor or representative).
8. **Maintenance.** During this Agreement's term, GPC will maintain the Equipment and will bear the cost of routine repair or replacement. Customer must notify GPC of any need for Equipment repair by either calling 1-888-850-4490 or by reporting the need online www.gpc.com/submit-service-request. Customer must notify GPC of any need for Equipment repair by either calling 1-888-850-4490 or by reporting the need online www.gpc.com/submit-service-request. Customer must first obtain GPC's written consent. Customer must call GPC Lighting Services Business Unit at 1-888-768-6468 to obtain the proper pole attachment authorization.
9. **Pole Attachment.** If Customer desires to attach anything to any Equipment (poles, split towers, etc.), Customer must first obtain GPC's written consent. Customer must call GPC Lighting Services Business Unit at 1-888-768-6468 to obtain the proper pole attachment authorization.
10. **Disclaimers.** GPC makes no covenant, warranty, or representation of any kind (including warranty of fitness for a particular purpose or of merchantability) regarding the Equipment or any GPC Activity. Customer also acknowledges that, due to the unique characteristics of the Premises, Customer's needs, or Equipment choice, the Equipment may not follow IEEE/ANSI guidelines. Customer waives any right to consequential, special, indirect, treble, exemplary, incidental, punitive, loss of business, regulation, or loss of use (including loss of revenue, profits, or capital costs) damages in connection with the Equipment or this Agreement, or arising from damage, hindrance, or delay involving the Equipment or this Agreement, whether or not reasonable, foreseeable, contemplated, or avoidable.
11. **Risk Allocation Liability.** Each Party will be responsible for its own acts and the results of its acts.
12. **Default.** Customer is in default if Customer does not pay the entire amount owed within 45 days of billing. GPC's waiver of any past default will not waive any other default. If default occurs, GPC, at its discretion, may immediately terminate this Agreement, collect all past due amounts (including late fees) and all amounts due for the Equipment during the remaining Agreement term, remove the Equipment from the Premises, and seek any other available remedy.
13. **Georgia Security, Installation, and Compliance Act.** Customer is a "public employer" as defined by O.C.G.A. § 13-10-91 and this Agreement is a contract for physical performance of services within the State of Georgia. Compliance with the requirements of O.C.G.A. § 13-10-91 and Rule 300-10-1-.02 is a condition of this Agreement and is mandatory. GPC's compliance with O.C.G.A. § 13-10-91 and Rule 300-10-1-.02 will be satisfied by execution of the contractor's affidavit attached as Exhibit "1" and made a part of this Agreement. GPC agrees that, if it employs or contracts with any subcontractor(s) in connection with this Agreement, GPC will secure from each subcontractor a statement of the subcontractor's compliance with O.C.G.A. § 13-10-91 and Rule 300-10-1-.02 by execution of a subcontractor's affidavit in the form attached as Exhibit "2." The affidavit will become a part of the GPC/subcontractor agreement and GPC will maintain records of the affidavits for inspection by Customer.
14. **Miscellaneous.** This Agreement contains the parties' entire agreement relating to the Equipment and replaces any other agreement, written or oral. Only a written amendment signed by each party can modify this Agreement, except that either party may update administrative or corded information (e.g., address, phone, website) at any time by written notice to the other party. Customer will not assign, in whole or in part, this Agreement or its Agreement rights or obligations without GPC's prior written consent. No assignment, whether with or without consent, releases Customer of its Agreement obligations. Customer must provide advance notice of a change in control of all, or substantially all, of Customer's ownership or interest in the Premises. In this Agreement, "binding" means "including, but not limited to." Georgia law governs this Agreement. If a court rules an Agreement provision unenforceable to any extent, the rest of that provision and all other provisions remain enforceable.

IN WITNESS WHEREOF, the parties hereto have caused this Agreement to be executed in three counterparts, each to be considered an original, by their authorized representative, on the day and date hereinabove written.

GEORGIA POWER COMPANY

DEKALB COUNTY, GEORGIA

By:

Signature (SEAL)

MICHAEL L. THURMOND
Chief Executive Officer
DeKalb County, Georgia (SEAL)

Print Name and Title

Date

Date

ATTEST:

ATTEST:

Witness

BARBARA SANDERS, CCC
Clerk of the Chief Executive Officer
And Board of Commissioners of
DeKalb County, Georgia

Name (Typed or Printed)

APPROVED AS TO FORM:

Title

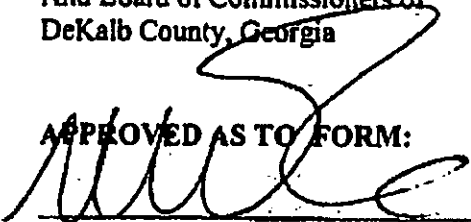

Matthew C. Welch
Supervising County Attorney Signature
DeKalb County, Georgia

APPROVED AS TO SUBSTANCE:

David Pelton, Director
Public Works Transportation Division
DeKalb County, Georgia

DEKALB COUNTY

ITEM NO. 18

BOARD OF COMMISSIONERS

BUSINESS AGENDA / MINUTES

MEETING DATE: March 28, 2017

HEARING TYPE
Action

ACTION TYPE
Resolution

SUBJECT: Georgia Department of Transportation (GDOT) Maintenance Agreement for Multi-Use Trail Bridge over I-285

Commission Districts – 4 and 6

DEPARTMENT: Public Works - Transportation

PUBLIC HEARING: YES NO

ATTACHMENT: YES No
PAGES: 19

INFORMATION CONTACT: David Pelton
PHONE NUMBER: 770-492-5206

Deferred 2/28/17
PURPOSE:

To consider entering into an agreement with the Georgia Department of Transportation (GDOT) for maintaining a proposed multi-use trail bridge over I-285 adjacent to Church Street; and

To consider authorizing the Chief Executive Officer to execute the necessary documents pertaining to this project.

NEED/IMPACT:

A proposed segment of the Atlanta-Stone Mountain Trail from Park North Boulevard to Mell Avenue will cross over I-285 adjacent to Church Street. An encroachment permit is needed from GDOT in order to construct this bridge. GDOT requires the signing of a maintenance agreement as a condition of issuing this permit. This trail project was advertised for bids on January 20, 2017 and will complete most of a missing segment of trail in the Clarkston area.

RECOMMENDATION(S):

Enter into an agreement with the Georgia Department of Transportation (GDOT) for maintaining a proposed multi-use trail bridge over I-285 adjacent to Church Street; and

Authorize the Chief Executive Officer to execute the necessary documents pertaining to this project.

FOR USE BY COMMISSION OFFICE/CLERK ONLY

ACTION : 2017-03-28 Item18

MOTION was made by Steve Bradshaw, seconded by Mereda Davis Johnson and passed 7-0-0-0 to approve and enter into an agreement with the Georgia Department of Transportation (GDOT) for maintaining a proposed Multi-use Trail Bridge over I-285 adjacent to Church Street; and Authorize the Chief Executive Officer to execute the necessary documents pertaining to this project.

ADOPTED: MAR 28 2017
(DATE)

PRESIDING OFFICER
DEKALB COUNTY BOARD OF
COMMISSIONERS

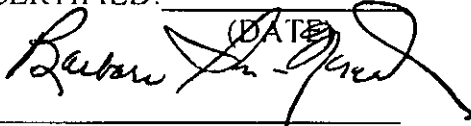
CERTIFIED: MAR 28 2017
(DATE)

CLERK,
DEKALB COUNTY BOARD
OF COMMISSIONERS

FOR USE BY CHIEF EXECUTIVE OFFICER ONLY

APPROVED: APR 05 2017
(DATE)

CHIEF EXECUTIVE OFFICER
DEKALB COUNTY

VETOED: _____
(DATE)

CHIEF EXECUTIVE OFFICER
DEKALB COUNTY

VETO STATEMENT ATTACHED: _____

MINUTES:

FOR : Kathie Gannon, Steve Bradshaw, Gregory Adams, Nancy Jester, Larry Johnson, Mereda Davis Johnson, Jeff Rader

AGAINST : None

ABSTAIN : None

ABSENT : None

ARTICLE I
SCOPE OF PROJECT

The **DEPARTMENT** shall permit the **LICENSEE** to perform or cause to be performed, the **PROJECT** consisting of certain services related to maintaining an identified section of the **DEPARTMENT'S** rights of way.

This permission shall be granted by the means of this Agreement for the entire scope of the **PROJECT**, as set forth herein.

The maintenance duties and responsibilities of the **LICENSEE** are defined and set forth in Article XI – **MAINTENANCE WORK PLAN** of this Agreement, and further enumerated and described in Exhibit 'A' – Application and Permit for Special Encroachment with approved drawings or final working drawings for a Department-approved construction **PROJECT**. Exhibit 'A' is attached hereto and incorporated by reference as if fully set out herein. The **PROJECT** location shall be defined or delineated as part of Exhibit 'A'. The required Special Encroachment Permit and/or the construction **PROJECT** final working drawings are to be approved or issued by the **DEPARTMENT**.

Should the **LICENSEE** desire that these maintenance services be performed by a third party, **LICENSEE** and the third party shall enter into subsequent agreement, whereby the **LICENSEE** shall assume all responsibility of repayment to the third party for those services to be rendered as set forth in Article XI - **MAINTENANCE WORK PLAN**. The Agreement between **LICENSEE** and any third parties to this Agreement, shall meet all operational and administrative requirements, including the provisions of liability insurance, set forth by the **DEPARTMENT**, and all liability associated with the **PROJECT** shall be borne by **LICENSEE** and any third parties, as set forth in Article VIII, herein.

Rev: September 13, 2010

RIGHT OF WAY MOWING AND MAINTENANCE AGREEMENT

By and Between

THE

GEORGIA DEPARTMENT OF TRANSPORTATION

AND

DEKALB COUNTY PUBLIC WORKS – TRANSPORTATION DIVISION

DeKalb County AMPS# 728363 SR407 Permit # 12-2016-038-089 MP 12.32
 {Pedestrian Bridge}

THIS AGREEMENT made and entered into this _____ day of _____, 20____ by and between the **DEPARTMENT** of Transportation, an agency of the State of Georgia, hereinafter alternately referred to as “**DEPARTMENT**” or “**LICENSOR**”, and DeKalb County Public Works – Transportation Division, hereinafter referred to as “**LICENSEE**”.

WHEREAS, the **DEPARTMENT** desires to enter into a public/private partnership to perform certain services relating to maintenance within **DEPARTMENT’S** right of way, hereinafter called the “**PROJECT**”, and

WHEREAS, the **LICENSEE** has represented to the **DEPARTMENT** that, if such permission is granted to the **LICENSEE**, **LICENSEE** shall bear all costs and liability associated with the **PROJECT**; and

WHEREAS, the **LICENSEE** has represented to the **DEPARTMENT** that they are qualified and experienced to provide such services and the **DEPARTMENT** has relied upon such representations;

NOW, THEREFORE, for and in consideration of the mutual promises and covenants as herein contained, it is agreed by and between the parties hereto that:

ARTICLE II
EXECUTION OF CONTRACT AND AUTHORIZATION
TIME OF PERFORMANCE

Time is of the essence in this agreement. The **LICENSEE** shall execute this Agreement and return it to the **DEPARTMENT** within thirty (30) days after receipt of contract forms from the **DEPARTMENT**.

The **LICENSEE** shall begin work on the **PROJECT** under this Agreement immediately after receiving a signed and executed copy of the Agreement (unless noted otherwise in Exhibit A or upon **PROJECT** construction completion).

Subject to the terms and conditions set forth in this Agreement, and upon execution of this Agreement, the **DEPARTMENT** grants the right to the **LICENSEE** to mow, edge, and maintain, as set forth in Article XI- **MAINTENANCE WORK PLAN**, that specific section of right-of-way identified in this Agreement, and herein defined as the **PROJECT**.

The duration of this Agreement shall not exceed fifty years from the date above first written unless terminated sooner by the **DEPARTMENT** or **LICENSEE**.

ARTICLE III
SUBSTANTIAL CHANGES

If, prior to the satisfactory completion of the services under this Agreement, any party materially alters the scope, character or complexity of the services from those required under the Agreement, a Supplemental Agreement shall be executed between the parties. It is understood, however, that **LICENSEE** shall not engage in any activities or conduct any work which would be considered to be outside the scope of the permission granted to **LICENSEE** by the **DEPARTMENT**. Minor changes in the work which do not involve increased compensation, extensions of time or changes in the goals and objectives of the work may be made by written notification of such change by any party with written approval by the other parties.

ARTICLE IV ASSIGNMENT

It is understood by the LICENSEE that the work is considered personal and, except as provided for in Article I, LICENSEE agrees not to assign, sublet or transfer any or all of their interest in this Agreement without prior written approval of the DEPARTMENT.

ARTICLE V CONTRACT DISPUTES

This Agreement shall be deemed to have been executed in Fulton County, Georgia, without reference to its choice of law doctrine, and all questions of interpretation and construction shall be governed by the laws of the State of Georgia. Any litigation arising out of this contract shall be commenced within the State of Georgia. The foregoing provisions shall not be construed as waiving any immunity to suit or liability, including without limitation, sovereign immunity which may be available to the Department.

ARTICLE VI INSURANCE

Prior to beginning work, the LICENSEE shall obtain or self-insure, and certify to the DEPARTMENT that it has the following minimum amounts of insurance coverage for anyone that will be working on the right of way:

- (a) Workmen's Compensation Insurance in accordance with the laws of the State of Georgia.
- (b) Public Liability Insurance in an amount of not less than one hundred thousand dollars (\$100,000) for injuries, including those resulting in death to any one person, and in an amount of not less than three hundred thousand dollars (\$300,000) on an account of any one occurrence, or proof of self-insurance.

(c) Property Damage Insurance in an amount of not less than fifty thousand dollars (\$50,000) from damages on account of any occurrence, with an aggregate limit of one hundred thousand dollars (\$100,000), or proof of self-insurance.

(d) Valuable Papers Insurance in an amount sufficient to assure the restoration of any plans, drawings, field notes, or other similar data relating to the work covered by the **PROJECT**.

(e) Insurance shall be maintained in full force and effect during the life of the **PROJECT**.

The **LICENSEE** shall furnish upon request to the **DEPARTMENT**, certificates of insurance evidencing such coverage. These certificates shall also provide that the insurance will not be modified or canceled without a 30 day prior written notice to the **DEPARTMENT**. Failure by the **LICENSEE** to procure and maintain the insurance as set forth above shall be considered a default and cause for termination of this Agreement and forfeiture of the Performance and Payment Bonds. The **LICENSEE** shall, at least fifteen (15) days prior to the expiration date or dates of expiring policies, deposit certified copies of renewal, or new policies, or other acceptable evidence of insurance with the **DEPARTMENT**.

ARTICLE VII COMPENSATION

It is agreed that **LICENSEE** shall conduct all work at no cost to the **DEPARTMENT**, and without compensation from the **DEPARTMENT**. It is further agreed that any and all issues relating to compensation and payment shall be resolved by and between **LICENSEE** and any successors, subcontractors, or assigns thereto.

The **DEPARTMENT** and **LICENSEE** further agree that, should the **DEPARTMENT** be required to conduct any inspections and/or supervision of the **PROJECT** beyond that which would normally occur in the ordinary course of the **DEPARTMENT'S** maintenance activities, **LICENSEE** shall reimburse the **DEPARTMENT** for such inspection and supervision. The rate of reimbursement for the **DEPARTMENT'S** inspection and supervision shall in no case exceed a rate determined to be reasonable by the parties.

Should **LICENSEE** and the **DEPARTMENT** desire to change this agreement at a later date to provide for compensation to **LICENSEE**, or any successors or assigns thereto, such change

shall only be permitted by a supplemental agreement as set forth in Article III herein. Any supplemental agreements involving compensation shall be subject to the **DEPARTMENT** review and approval.

ARTICLE VIII
RESPONSIBILITY FOR CLAIMS AND LIABILITY
LICENSEE NOT AGENT OF DEPARTMENT

To the extent permitted by law, **LICENSEE**, and all successors and assigns thereto, shall save harmless the **DEPARTMENT**, its officers, agents, and employees from all suits, claims, actions or damages of any nature whatsoever resulting from the performance of work assigned to **LICENSEE** under this Agreement. **LICENSEE** further agrees that they shall be fully responsible for injury or damage to landscaping, landscape related items, and any other non-standard and decorative elements installed by or for the **LICENSEE** within the right of way, and for any damage to the **DEPARTMENT'S** signs, structures, or roadway fixtures, if **LICENSEE** causes the damage. These indemnities shall not be limited by reason of the listing of any insurance coverage.

It is further understood and agreed that **LICENSEE**, or any successor or assigns thereto, in the conduct of any work involved in the **PROJECT**, shall not be considered the agent of the **DEPARTMENT** or of the State of Georgia.

ARTICLE IX
TERMINATION OF CONTRACT

The **DEPARTMENT** may terminate this contract for just cause at any time by giving of thirty (30) days written notice of such termination. Upon receipt of such notice of termination, **LICENSEE** shall discontinue and cause all work under this contract to terminate upon the date specified in the said notice. In the event of such termination, the **DEPARTMENT** shall be paid for any amounts as may be due it as specified in Article VII up to and including the specified date of termination. **LICENSEE** shall have the right to terminate this contract at any time, provided that such termination is first approved by the **DEPARTMENT**, and that the **DEPARTMENT** is reimbursed in full for all services rendered pursuant to Article VII.

The **DEPARTMENT** and **LICENSEE** further agree that, should the **DEPARTMENT** allow the **LICENSEE** to terminate the agreement, the termination, unless determined otherwise in writing by the **DEPARTMENT**, shall be contingent upon the following:

- A. The **LICENSEE**, at the discretion of the **DEPARTMENT**, removing the planted landscaping, landscape related items, and any other non-standard and decorative elements that were installed by or for the **LICENSEE** at no cost to the **DEPARTMENT**.
- B. The **LICENSEE** restoring the removed landscape areas to their original condition or a condition that meets federal standards and is acceptable to the **DEPARTMENT**.
- C. The **LICENSEE** restoring the removed non-standard and decorative elements with standard **DEPARTMENT** elements that meet federal and state requirements.
- D. The **LICENSEE** reimbursing the **DEPARTMENT** in full any state and/or federal funds used to purchase and install the landscaping, landscape related items, and other non-standard and decorative elements that are no longer to be maintained by the **LICENSEE**.
- E. No reimbursal is required for termination of agreements for Mowing Only.

The **DEPARTMENT** and the **LICENSEE** agree that, should the **LICENSEE** fail to perform the maintenance, as set forth in Article XI - **MAINTENANCE WORK PLAN**, the **DEPARTMENT** may require the **LICENSEE** to remove, restore, and reimburse according to items "A", "B", "C", and "D" above, as applicable, and then terminate the agreement.

ARTICLE X

COMPLIANCE WITH APPLICABLE LAW

The undersigned certify that:

- A. This Agreement is subject to applicable state and federal laws, standards, and rules and regulations.
- B. The provisions of Sections 45-10-20 through 45-10-28 of the Official Code of Georgia Annotated relating to Conflict of Interest and State Employees and Officials Trading with the State have been complied with in full.
- C. The provisions of Section 50-24-1 through 50-24-6 of the Official Code of Georgia Annotated, relating to the "Drug-Free Workplace Act" have been complied with in full.

ARTICLE XI**MAINTENANCE WORK PLAN**

LICENSEE is to provide any and all needed maintenance to the pedestrian bridge permitted and constructed as part of **PROJECT**. See Exhibit 'A'.

The covenants herein contained shall, except as otherwise provided, accrue to the benefit of and be binding upon the successors and assigns of the parties hereto.

IN WITNESS WHEREOF, said parties have hereunto set their hand and affixed their seals the day and year above first written.

**GEORGIA DEPARTMENT OF
TRANSPORTATION**

DEKALB COUNTY, GEORGIA

Commissioner or designee

by Dir.(SEAL)
MICHAEL L. THURMOND
Chief Executive Officer
DeKalb County, Georgia

ATTEST:

Angela Whitworth
Treasurer

Date

ATTEST:

BARBARA SANDERS-NORWOOD, CCC,
CMC
Clerk of the Chief Executive Officer
And Board of Commissioners of
DeKalb County, Georgia

Date

Sworn before me this
_____ day of _____, 2017

NOTARY PUBLIC

My commission expires _____, _____

APPROVED AS TO FORM:

County Attorney Signature

County Attorney Name (Typed or Printed)

APPROVED AS TO SUBSTANCE:

David Pelton

Department Director

EXHIBIT 'A'

(Attach the Application and Permit for Special Encroachment with approved drawings or the final working drawings for a Department-approved construction).

Russell R. McMurry, P.E., Commissioner

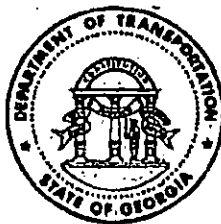

GEORGIA DEPARTMENT OF TRANSPORTATION

One Georgia Center, 600 West Peachtree Street, NW
Atlanta, Georgia 30308
Telephone: (404) 631-1000

December 5, 2016

DeKalb County Public Works Department - Transportation Division
1950 West Exchange Place
Tucker, Georgia 30084
ATTN: Mr. David Pelton

Re: Special Encroachment Permit #12-2016-038-089, AMPS 728363, DeKalb County, S.R. 407, MP 12.32

Dear Applicant:

Your permit has been approved, however; before final authorization can be made, you must return the documents specified on the attached "Instruction List" to the person shown. Upon receipt of these items, we will issue to you a "Document Receipt". You or a qualified representative on the project should contact our Area Engineer who will authorize the issuance of your permit for construction. This approval is subject to the revisions and additions shown in red on the plans, which are with your permit. The plans should be discussed with the permit inspector at that time. Your copy of the permit along with this letter should be kept at the construction site and available for inspection at all times. The red identification sign, which will accompany the permit, must be displayed within the working area and visible from the highway.

It shall be your responsibility to notify the inspector when the work authorized by this permit is complete. A final inspection will be scheduled at that time for the release of your bond. No work should be considered accepted by the Georgia DOT until you are notified in writing.

If you have any questions, please call (770) 216-3893.

Yours very truly,

Kathy Zahul, P.E.
District Engineer

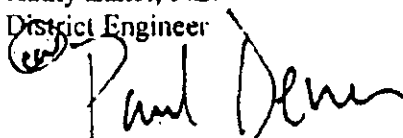
by: Paul DeNard, P.E., P.T.O.E.
District Traffic Engineer

KZ:PD:bc

cc: Andrew Heath, P.E., State Traffic Engineer (Attn: Daphne Cautela)
J. Brad Humphrey, Area 1 Engineer (Attn: Reuben Woods)
City of Clarkston

Instruction List

Location:

The work to be performed is located at the property on the E. & W. side of highway, beginning 50 feet \pm S. of the centerline of E. Ponce de Leon Avenue, fronting 20 feet \pm further S. and at milepost 12.32.

Stipulations:

Before your permit can be released for construction you must return the following documents to Traffic Operations Office of the Georgia Department of Transportation at 5025 New Peachtree Road NE - Chamblee, Georgia 30341. **Please call 24 hours in advance for an appointment so Bryan Carter will be present to issue you your document receipt. (770) 986-1772 or br Carter@dot.ga.gov**

- An original Performance Bond or Letter of Escrow in the Amount of **\$100,000.00**. (Sample and original bond form enclosed). **The Department is unable to accept performance bond documents that have been photocopied or faxed at any time. Please submit only the original performance bond document provided by this office. Also, please use a GEORGIA-HOUSED bonding agency, or have a GEORGIA RESIDENT AGENT provide their signature and address in the designated area on the bond form. (If a Blanket Bond is being used to cover the work authorized by this permit a copy of the Blanket Bond needs to be provided to this office).**
- Maintenance Agreement

Special Stipulations:

The Georgia Department of Transportation may curtail any work activities authorized under this permit, if Department representatives deem the existing or expected traffic conditions could be negatively impacted.

Construction on the right-of-way is to begin only when the site construction is begun, including buildings, parking lots, etc. and is approved only for the type business indicated on the application. Any change in site usage will require a revision to this permit.

DATE	PROJECT NUMBER	SCALE	DATE
CA.			

GENERAL NOTES

SPECIFICATIONS - GEORGIA STANDARD SPECIFICATIONS, 2013 EDITION, AS MODIFIED BY CONTRACT DOCUMENTS.

REINFORCING STEEL - PLACE AND TIE ALL REINFORCING STEEL IN ACCORDANCE WITH THE GEORGIA DOT SPECIFICATIONS. DO NOT WELD REINFORCING STEEL.

CHAMFER - CHAMFER ALL EXPOSED CONCRETE EDGES UNLESS OTHERWISE NOTED.

TEMPORARY SHORING - INCLUDE THE COST OF TEMPORARY SHORING AS NECESSARY FOR BRIDGE CONSTRUCTION IN THE OVERALL BID SUBMITTED.

TRAFFIC CONTROLS - SEE SPECIAL PROVISIONS FOR TRAFFIC CONTROLS AND TRAFFIC CONTROL PAYMENT.

EXISTING SLOPE PAVING - TAKE CARE TO PREVENT DAMAGING THE EXISTING SLOPE PAVING. REPAIR ANY DAMAGE THAT OCCURS TO THE SLOPE PAVING, OTHER THAN THAT REQUIRED TO BE REMOVED FOR SUBSTRUCTURE EXCAVATION AND TO TIE NEW SLOPE PAVING INTO EXISTING SLOPE PAVING. MATCH THE NEW SLOPE PAVING TO EXISTING SLOPE PAVING. INCLUDE THE COST FOR REMOVAL OF SLOPE PAVING IN THE OVERALL BID SUBMITTED.

EXISTING CONCRETE DITCH PAVING - TAKE CARE TO PREVENT DAMAGING THE EXISTING CONCRETE DITCH PAVING. REMOVE ONLY THE PORTION OF CONCRETE DITCH PAVING THAT IS NECESSARY FOR SUBSTRUCTURE EXCAVATION AND REPAIR ANY DAMAGE THAT OCCURS TO THE CONCRETE DITCH PAVING. REBUILD ALL PORTIONS OF CONCRETE DITCH PAVING REMOVED TO RETURN TO EXISTING CONDITION, INCLUDING DRAINAGE FLOW. INCLUDE THE COST FOR REMOVAL AND REBUILDING OF CONCRETE DITCH PAVING IN THE OVERALL BID SUBMITTED.

WAITING PERIOD - NONE REQUIRED.

INTERMEDIATE BENT EXCAVATION - WHEN EXCAVATING, TAKE CARE NOT TO DISTURB THE EXISTING FOOTINGS. BLASTING WILL NOT BE ALLOWED.

FOOTING ELEVATIONS - DO NOT LOWER FOOTING ELEVATIONS, AS SHOWN ON THE PLANS, MORE THAN 3'-0" WITHOUT THE APPROVAL OF THE STATE BRIDGE ENGINEER.

FOUNDATION BACKFILL MATERIAL - PLACE 3'-0" OF TYPE II FOUNDATION BACKFILL MATERIAL UNDER EACH FOOTING AT BENTS 2 AND 3. THE QUANTITY IS BASED ON THE PLAN FOOTING DIMENSIONS PLUS 2'-0".

PLAN DRIVING OBJECTIVE - SEE SUBSTRUCTURE DETAILS.

ANCHOR BOLTS - PLACE ANCHOR BOLTS IN FORMER 3" DIAMETER 4' DEEP HOLES AND GROUT IN PLACE AS PER SUB-SECTION 501.3.05.B.3 OF THE GEORGIA DOT SPECIFICATIONS. STIRRUPS MAY BE SHIFTED SLIGHTLY TO CLEAR ANCHOR BOLT HOLES.

WELDING - ALL WELDING ON GEORGIA DOT PROJECTS SHALL BE PERFORMED BY CERTIFIED WELDERS THAT HAVE IN THEIR POSSESSION A CURRENT WELDING CERTIFICATION CARD ISSUED BY THE OFFICE OF MATERIALS AND TESTING. USE ONLY E7018 (ELECTRODE E7018 AND E7024) LOW HYDROGEN ELECTRODES FOR MANUAL SHIELDED METAL ARC WELDING.

INCIDENTAL ITEMS - INCLUDE THE COST INCIDENTAL TO THE WORK THAT IS NOT SPECIFICALLY COVERED BY THE GEORGIA STANDARD SPECIFICATIONS, SUPPLEMENTAL SPECIFICATIONS AND/OR SPECIAL PROVISIONS IN THE OVERALL BID SUBMITTED. THIS INCLUDES THE COST OF JOINT FILLERS AND OTHER INCIDENTAL ITEMS NECESSARY TO COMPLETE THE WORK.

STORAGE OF CONSTRUCTION MATERIALS - THE CONTRACTOR SHALL BE REQUIRED TO MAINTAIN CLEAR ZONE WHILE STAGING EQUIPMENT AND MATERIALS DURING CONSTRUCTION. IF MATERIALS OR EQUIPMENT ARE STORED UNDER EXISTING GUARDRAIL IN THE SHOULDERS, THE CONTRACTOR SHALL ENSURE THAT THERE CONTINUES TO BE AN ADEQUATE LENGTH OF GUARDRAIL. TEMPORARY BARRIER MAY BE REQUIRED IF THE LENGTH OF GUARDRAIL BECOMES INADEQUATE AS DETERMINED BY THE FIELD ENGINEER.

ERECTION OPERATIONS FOR PREFABRICATED BRIDGE - THE ERECTION OPERATION FOR SPAN 2 OF THE PREFABRICATED BRIDGE OVER I-285 SHALL BE PERFORMED ON A WEEKEND BETWEEN THE HOURS OF MIDNIGHT SATURDAY TO 4:00 A.M. SUNDAY. DURING THIS OPERATION TRAFFIC SHALL BE PAVED IN ACCORDANCE WITH THE REQUIREMENTS OF SPECIAL PROVISIONS. UNDER NO CIRCUMSTANCES SHALL LANE CLOSURES DURING THE DAYTIME OR DURING THE WEEK BE CONSIDERED BY THE GEORGIA DOT.

SHOP SPICES - ALL SHOP SPICES ARE TO BE SHOWN ON THE SHOP DRAWINGS.

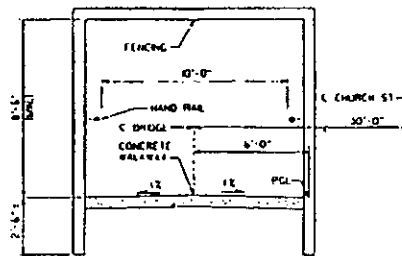

TYPICAL SECTION
NO SCALE

LOAD	VERTICAL	TRANSVERSE	LONGITUDINAL
DEAD LOAD	21.745		
PEDESTRIAN LIVE LOAD	14.060		
VEHICULAR LIVE LOAD	10.000		
WIND UPLIFT	-5.750		
WIND	14.860	5.240	
THERMAL			2.265

LOAD	VERTICAL	TRANSVERSE	LONGITUDINAL
DEAD LOAD	30.725		
PEDESTRIAN LIVE LOAD	36.595		
VEHICULAR LIVE LOAD	10.000		
WIND UPLIFT	-14.965		
WIND	115.160	14.115	
THERMAL			10.615

LOAD	VERTICAL	TRANSVERSE	LONGITUDINAL
DEAD LOAD	16.550		
PEDESTRIAN LIVE LOAD	10.715		
VEHICULAR LIVE LOAD	10.000		
WIND UPLIFT	-4.380		
WIND	43.625	3.995	
THERMAL			2.490

REACTIONS ARE PER BEARING 44 PER TRUSS SPAN
DEAD LOAD INCLUDES CONCRETE DECK

DESIGN DATA

SPECIFICATIONS ----- AASHTO GUIDE SPECIFICATIONS FOR THE DESIGN OF PEDESTRIAN BRIDGES

PEDESTRIAN LOADING ----- 85 PSF

VEHICULAR LOADING ----- H-10 (TRUCK, WITHOUT IMPACT)

CONCRETE SUPERSTRUCTURE ----- CLASS AA, G = 3,400 PSI

SUBSTRUCTURE ----- CLASS AA, G = 3,500 PSI

STRUCTURAL STEEL (PREFABRICATED BRIDGE) ----- SEE SPECIAL PROVISIONS

REINFORCEMENT STEEL ----- GRADE 60, G = 60,000 PSI

BRIDGE CONSISTS OF

- 1 - 63'-0" THROUGH TRUSS SIMPLE SPAN ----- SPECIAL DESIGN BY CONTRACTOR
- 1 - 164'-0" THROUGH TRUSS SIMPLE SPAN ----- SPECIAL DESIGN BY CONTRACTOR
- 1 - 48'-0" THROUGH TRUSS SIMPLE SPAN ----- SPECIAL DESIGN BY CONTRACTOR
- 2 - STEEL H PILE PILE END BENTS ----- SPECIAL DESIGN
- 2 - CONCRETE INTERMEDIATE BENTS ----- SPECIAL DESIGN
- BAR BENDING DETAILS ----- GA STD. 3031 (4-85)
- PIPE HANDRAIL FOR RETAINING WALL ----- GA STD. 3031R (10-11-00)
- TYPICAL FILL DETAIL AT END OF BRIDGE ----- GA STD. 3031 (9-99)

SUMMARY OF QUANTITIES

PAY ITEM NUMBER	QUANTITY	UNIT	PAY ITEM
207-0203	32	CY	FOUND BKFL MTL, 1P 11
211-0200	138	LF	BRIDGE EXCAVATION, GRADE SEPARATION
441-0004	76	SF	EDGE SLOPE PAV, 4 IN
441-0204	31	SF	PLAIN EDGE DITCH PAVING, 4 IN
500-3002	125	CY	CLASS AA CONCRETE
511-1000	19133	LB	BAR REINF STEEL
520-1125	180	LF	PIILING IN PLACE, STEEL H, HP 12 x 53
520-4125	4	EA	LOAD TEST, STEEL H, HP 12 x 53 (1F REQD)
515-2020	44	LF	GALV STEEL PIPE HANDRAIL, 2 IN, ROUND
534-1000	LUMP	-	PEDESTRIAN OVERPASS BRIDGE, STA 31-67

BRIDGE NO. 1



GEORGIA
DEPARTMENT OF TRANSPORTATION
ENGINEERING DIVISION - OFFICE OF BRIDGES AND STRUCTURES

GENERAL NOTES
PEDESTRIAN BRIDGE OVER I-285
AT CHURCH STREET
DEKALB COUNTY

DRAWING NO. 35-002	SCALE: NONE	DATE JUNE 2016
BRIDGE SHEET 2 OF 1	DESIGNED BY SJM	CHECKED BY SJM

UNLAWFUL TO REPRODUCE OR TRANSMIT IN ANY FORM OR BY ANY MEANS, ELECTRONIC OR MECHANICAL, INCLUDING PHOTOCOPYING, RECORDING, OR BY ANY INFORMATION STORAGE AND RETRIEVAL SYSTEM.

11-0027-D5 (2/2016) B. Burdette, R. J. Hill, 2015-2016

8/2/16 3:11

8/11/2016

DATE	PROJECT NUMBER	SCALE	SHEET NUMBER
GA.			

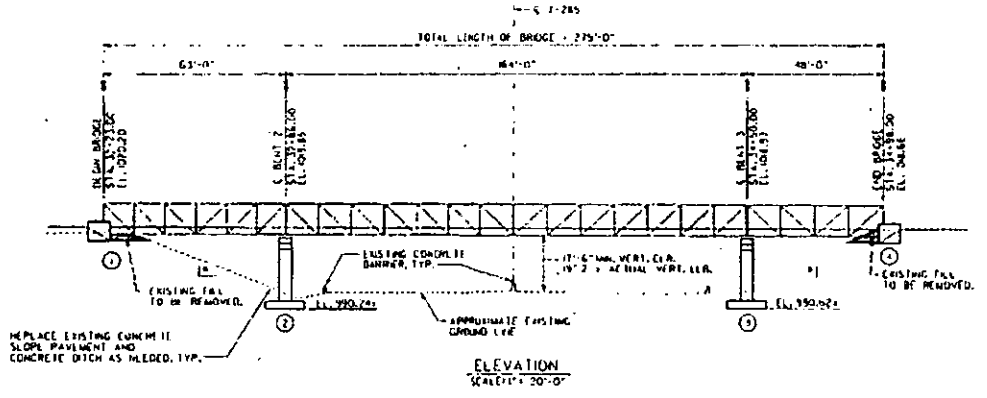
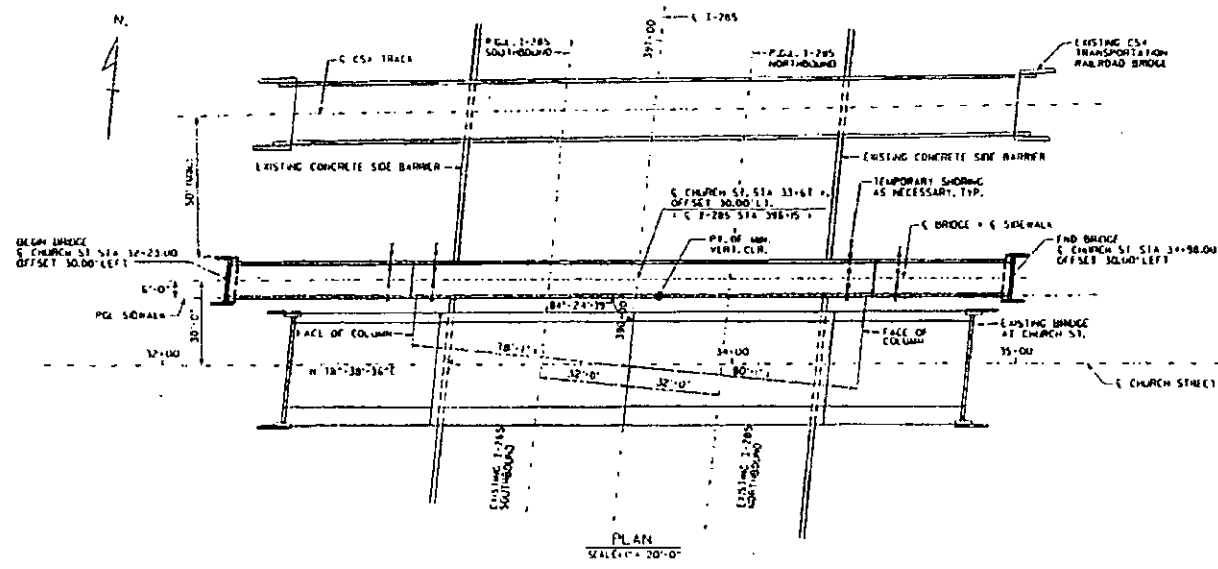

- NOTES:
- EXISTING SLOPE TO REMAIN.
 - STATIONS AND ELEVATIONS ARE ALONG C BRIDGE LINE AT THE INTERSECTION OF C BRIDGE LINE AND FRONT FACE OF BACK WALL UPDOWN C BRIDGE.
 - ALL DENTS ARE PARALLEL TO C I-285.
 - END DENT PILES NOT SHOWN.

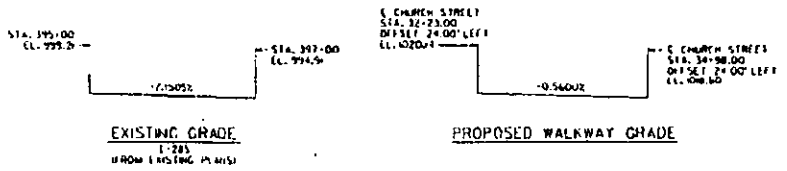

BRIDGE NO. 1

ATKINS

GEORGIA
DEPARTMENT OF TRANSPORTATION
ENGINEERING DIVISION - OFFICE OF BRIDGES AND STRUCTURES

PLAN AND ELEVATION
PEDESTRIAN BRIDGE OVER I-285
AT CHURCH STREET
DEKALB COUNTY

SCALE: AS SHOWN

DATE: _____
REVISIONS: _____
DATE: _____

DRAWING NO. 33-00H
BRIDGE SHEET 1 OF 3

DESIGNED BY: _____ CHECKED BY: _____
DRAWN BY: _____ DATE: _____

APR 2016

11-10627-105 17814 w.c. for reprint of final file, 2015 year 00
93410 24
5-22-2016

FOR BRIDGES 1/8" OR MORE PRINTS FULL SIZE

DATE	PROJECT NUMBER	SHEET NO.	TOTAL SHEETS
GA.			

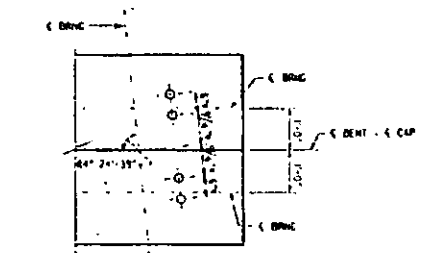
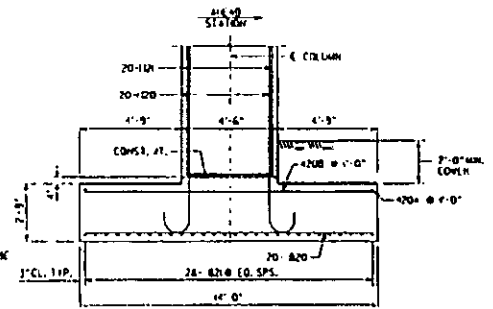
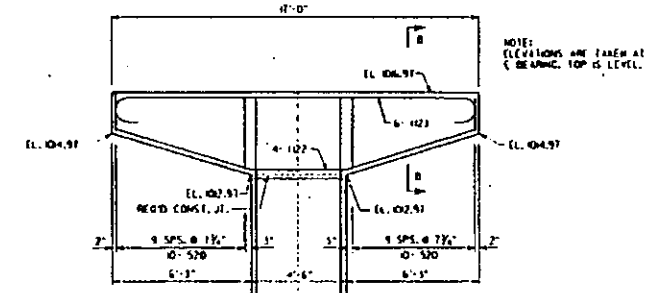
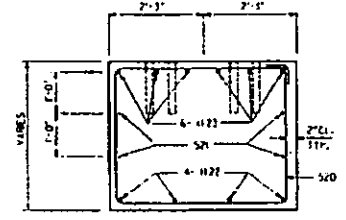
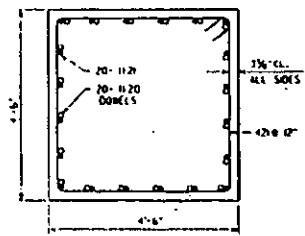
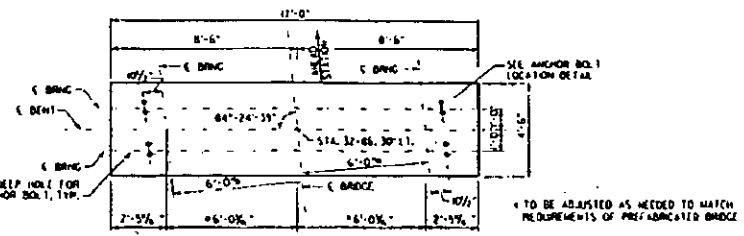

SUBSTRUCTURE QUANTITIES		
ITEM	BEWT 2	
C1 CLASS "AA" CONCRETE	52.8	
LB BAR REINFORCEMENT STEEL	6019	

BRIDGE NO. 1

ATKINS

GEORGIA
DEPARTMENT OF TRANSPORTATION
ENGINEERING DIVISION - OFFICE OF BRIDGES AND STRUCTURES

INTERMEDIATE BENT 2
PEDESTRIAN BRIDGE OVER I-285
AT CHURCH STREET
DEKALB COUNTY

SCALE: AS SHOWN

JUNE 2008

DRAWING NO. 25-004	ISSUED BY CAB	ISSUED TO CAB	DATE JUN 2008
BRIDGE SHEET 4 OF 7			

11/20/08 10:58 AM C:\projects\Bent2\Drawings\25-004.dwg
 11/27/08 10:58 AM C:\projects\Bent2\Drawings\25-004.dwg

DATE	BY	CHKD	APP'D
GA.			

LOCATION	SIA. 7A
BEGIN BRIDGE BENT 1	32+23.00
END BRIDGE BENT 4	34+98.00

- NOTES
1. MAINTAIN 2" CLEARANCE TO ALL REINFORCEMENT UNLESS NOTED OTHERWISE.
 2. BOTTOM OF CAP IS LEVEL.
 3. # TO BE ADJUSTED AS NEEDED TO MATCH REQUIREMENTS OF PREFABRICATED BRIDGE.
 4. SIA. 7A IS REFERENCED TO THE C CHURCH STREET, OFFSET 30.00' LEFT.

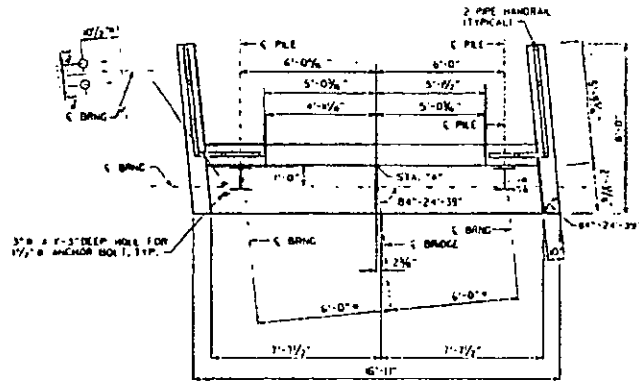

PLAN
SCALE: 1/4" = 1'-0"

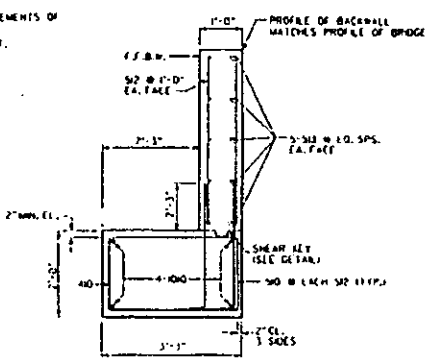

SECTION A-A
SCALE: 1" = 1'-0"

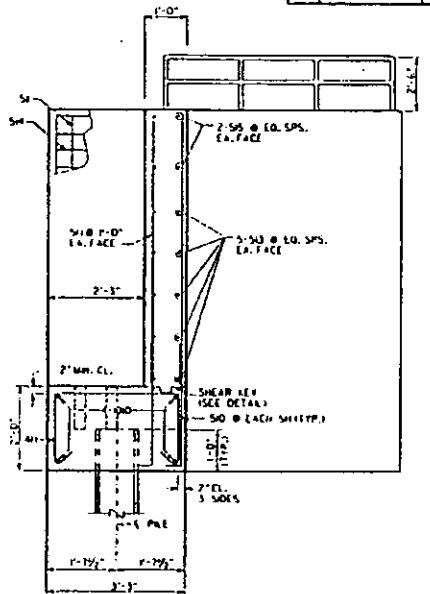

SECTION B-B
SCALE: 1" = 1'-0"

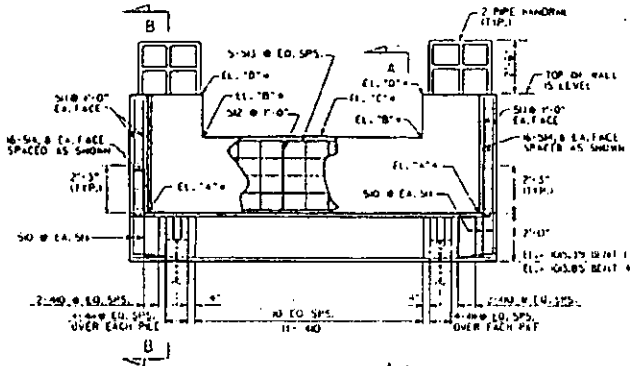

ELEVATION
SCALE: 1/4" = 1'-0"

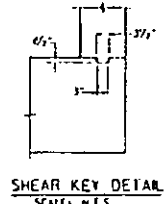

SHEAR KEY DETAIL
SCALE: N.T.S.

NOTE:
ALL PILES SHALL BE STEEL H.P. 12 X 55.

PILE DRIVING OBJECTIVE

ALL PILES SHALL BE DRIVEN TO A DRIVING RESISTANCE OF 10 TONS (AFTER WEDGEM TIP ELEVATIONS OF 975.0 AT END BENT 1 AND 980.0 AT END BENT 4 ARE ACHIEVED).

BENT	EL. "A"	EL. "B"	EL. "C"	EL. "D"
END BENT 1	1077.35	1120.16	1020.20	1022.14
END BENT 4	1055.85	1098.00	1008.00	1010.00

NOTE: ELEVATIONS ARE TAKEN AT C BEARING.

ITEM	END BENT 1	END BENT 4
CY CLASS "A" CONCRETE	9.8	9.8
LB BARS REINFORCEMENT STEEL	1550	1550
PIPE GUARDRAIL, LF	22	22

BRIDGE NO. 1

ATKINS

GEORGINA
DEPARTMENT OF TRANSPORTATION
ENGINEERING DIVISION - OFFICE OF BRIDGES AND STRUCTURES

END BENTS 1 AND 4
PEDESTRIAN BRIDGE OVER I-285
AT CHURCH STREET

DEKALB COUNTY

SCALE: AS SHOWN

JUNE 2004

DRAWING NO.	15-003
BRIDGE SHEET	5 OF 7

11-0002 (03) (REVISED) BRIDGE NO. 1 AT CHURCH STREET, DEKALB COUNTY, GEORGIA
4-2-04 244

DATE	SHEET NUMBER	SHEET NO.	TOTAL SHEETS
GA.			

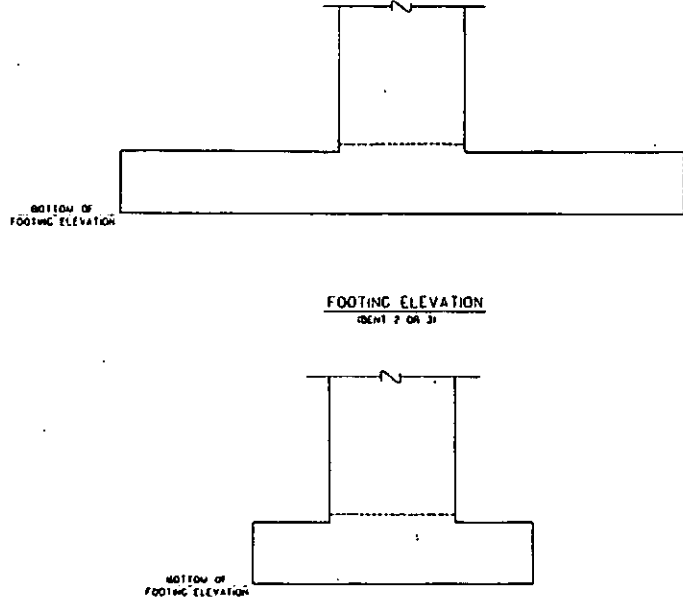
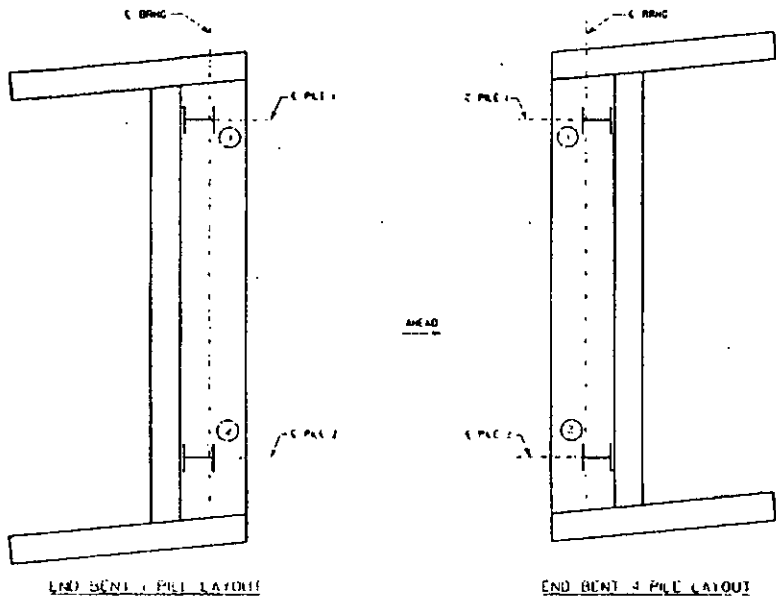

AS-BUILT FOUNDATION INFORMATION		
BENT	PILE LOCATION	PILE TIP ELEVATION
1		
4		

AS-BUILT FOUNDATION INFORMATION		
BENT	FOOTING LOCATION	BOTTOM OF FOOTING ELEVATION
2	STA. 32+46.00	
3	STA. 34+50.00	

NOTE: THIS "AS-BUILT FOUNDATION INFORMATION" SHEET SHALL BE FILLED IN BY THE PROJECT ENGINEER AND FORWARDED TO THE OFFICE OF CONSULTANT DESIGN, AFTER INSTALLATION OF ALL PILES AND SPREAD FOOTINGS, FOR POSTING TO THE PLANS AS A PERMANENT RECORD OF THE BRIDGE CONSTRUCTION.

12/12/2014 10:52:45 AM 10/25/2014 10:52:45 AM 10/25/2014 10:52:45 AM 10/25/2014 10:52:45 AM

BRIDGE NO. 1

ATKINS

GEORGIA
 DEPARTMENT OF TRANSPORTATION
 ENGINEERING DIVISION - OFFICE OF BRIDGES AND STRUCTURES

AS-BUILT FOUNDATION INFORMATION
 PEDESTRIAN BRIDGE OVER I-285
 AT CHURCH STREET
 DEKALB COUNTY

SCALE: NONE JUNE 2006

DRAWING NO. 15-006	BRIDGE SHEET 6 OF 7	DATE 10/25/2014	DESIGNED BY J.M.	CHECKED BY J.M.	APPROVED BY J.M.
-----------------------	------------------------	--------------------	---------------------	--------------------	---------------------

UNIVERSITY MICROFILMS INTERNATIONAL

DATE	BY	CHECKED	DATE

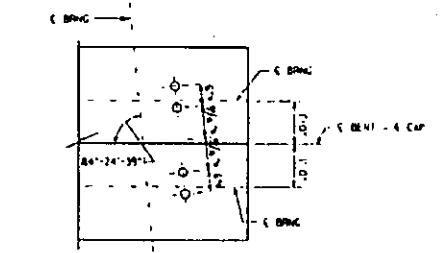
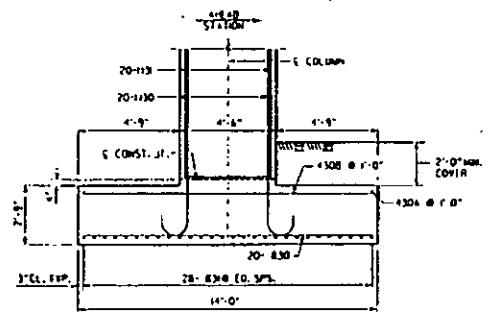
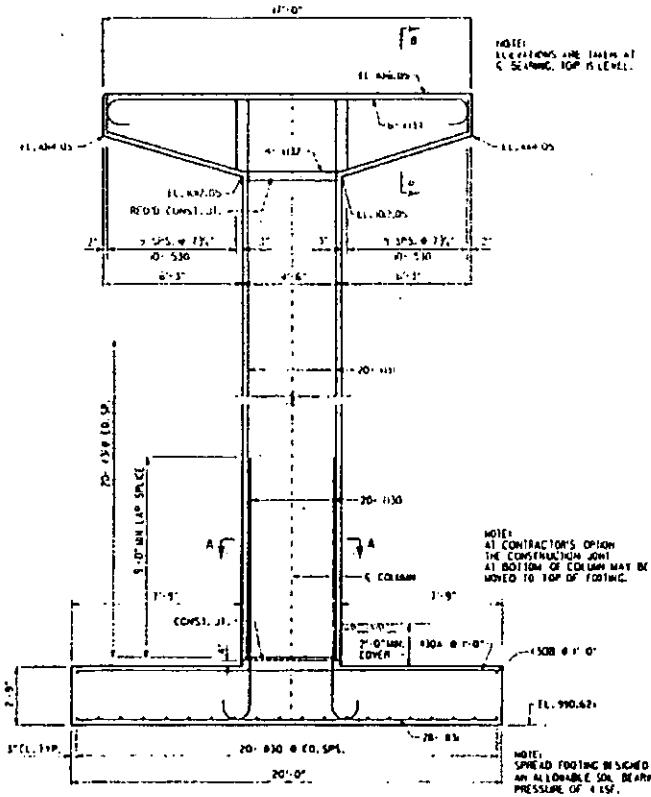
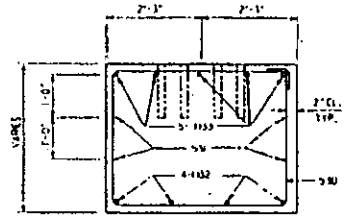
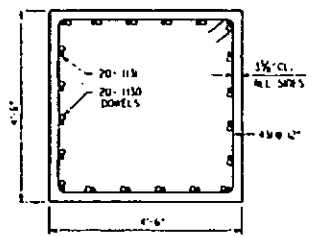
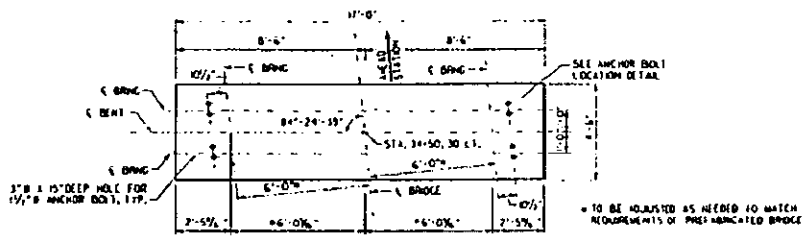

SUBSTRUCTURE QUANTITIES	
ITEM	BENT 3
CT CLASS "A" CONCRETE	513
LB BAR REINFORCEMENT STEEL	7945

ATKINS

BRIDGE NO. 1
GEORGIA
DEPARTMENT OF TRANSPORTATION
ENGINEERING DIVISION - OFFICE OF BRIDGES AND STRUCTURES

INTERMEDIATE BENT 3
PEDESTRIAN BRIDGE OVER I-285
AT CHURCH STREET
DEKALB COUNTY

SCALE AS SHOWN

JUNE 2006

DRAWING NO. 15-005	DATE	BY	CHECKED
BRIDGE SHEET 5 OF 1			

4-17-2006 3:34:03 PM C:\Users\jgibson\Documents\Bent3.dwg 2015 v13.rvt

DEKALB COUNTY

ITEM NO. 19

BOARD OF COMMISSIONERS

BUSINESS AGENDA / MINUTES

MEETING DATE: March 28, 2017

HEARING TYPE
Preliminary

ACTION TYPE

SUBJECT: Purchases - RFP1. Street Level Imagery-Phase II

DEPARTMENT: Purchasing and Contracting

PUBLIC HEARING: YES NO XX

ATTACHMENT: YES No
PAGES:

INFORMATION CONTACT: Talisa R. Clark, CPPO
Interim Chief Procurement Officer
PHONE NUMBER: (404) 687-2797

Deferred 3/14/17
PURPOSE:

To consider award for purchases as attached.

NEED/IMPACT:

To provide for items and service to carry on the operation of the County. Approval will contribute to the efficient operation of the County by providing for needs of various departments.

RECOMMENDATION(S):

See end of each subject on attached. Unless otherwise noted, the recommended firm is low bidder as well as having met specifications

FOR USE BY COMMISSION OFFICE/CLERK ONLY

ACTION : 2017-03-28 Item19 RFP1

MOTION was made by Steve Bradshaw, seconded by Mereda Davis Johnson and passed 7-0-0-0 to approve the Request for Proposal No. 16-500416, for street Level Imagery-Phase II, for use by the Property Appraisal Department, with an amount not to exceed \$848,335.56.

ADOPTED: MAR 28 2017
(DATE)

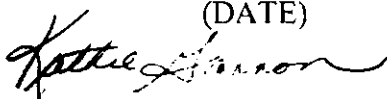

PRESIDING OFFICER
DEKALB COUNTY BOARD OF
COMMISSIONERS

CERTIFIED: MAR 28 2017
(DATE)

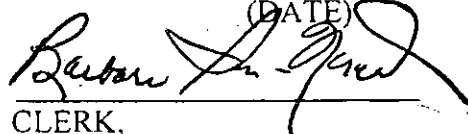

CLERK,
DEKALB COUNTY BOARD
OF COMMISSIONERS

FOR USE BY CHIEF EXECUTIVE OFFICER ONLY

APPROVED: APR 05 2017
(DATE)



CHIEF EXECUTIVE OFFICER
DEKALB COUNTY

VETOED: _____
(DATE)

CHIEF EXECUTIVE OFFICER
DEKALB COUNTY

VETO STATEMENT ATTACHED: _____

MINUTES:

FOR : Kathie Gannon, Steve Bradshaw, Gregory Adams, Nancy Jester, Larry Johnson, Mereda Davis Johnson, Jeff Rader

AGAINST : None

ABSTAIN : None

ABSENT : None

REQUEST
FOR
PROPOSAL

RFPI. Street Level Imagery-Phase II: Request for Proposals No. 16-500416 for use by the Property Appraisal Department. Consists of the conversion of current paper-based property record cards to digital images in the County's iasWorld CAMA system. One (1) proposal was received. Recommend award to the only proposer who is responsive and responsible:

Tyler Technologies, Inc., One Tyler Way, Moraine, OH 45439

Amount Not To Exceed: \$848,335.56

and authorize the Chief Executive Officer to execute the contract and all associated documents.

Evaluation Committee Score

<u>Firm</u>	<u>Score</u>
Tyler Technologies, Inc.	97.80

After evaluation of technical and cost proposals, the recommendation is to award to the only proposer.

Notes:

- | | |
|------------------------------|---|
| 1. Commission District(s): | All |
| 2. LSBE Participation: | 21% |
| 3. Contract Effective Date: | Date of Award |
| 4. Contract Expiration Date: | December 31, 2018 |
| 5. Funding: | Capital Improvement Projects (Property Appraisal) |

DEKALB COUNTY

ITEM NO. 110

BOARD OF COMMISSIONERS

BUSINESS AGENDA / MINUTES

MEETING DATE: March 28, 2017

HEARING TYPE
Action

ACTION TYPE

SUBJECT: Purchases - CO1. Change Order No. 1 to Contract No. 14-902807 for Ethernet Dedicated Internet (Multi-year Contract)

DEPARTMENT: Purchasing and Contracting

PUBLIC HEARING: YES NO XX

ATTACHMENT: x YES No
PAGES:

INFORMATION YES
CONTACT: Talisa R. Clark, CPPO
Interim Chief Procurement Officer
PHONE NUMBER: (404) 687-2797

Deferred 3/14/17

PURPOSE:

To consider award for purchases as attached.

NEED/IMPACT:

To provide for items and service to carry on the operation of the County. Approval will contribute to the efficient operation of the County by providing for needs of various departments.



RECOMMENDATION(S):

See end of each subject on attached. Unless otherwise noted, the recommended firm is low bidder as well as having met specifications

FOR USE BY COMMISSION OFFICE/CLERK ONLY

ACTION : 2017-03-28 Item10 COI

MOTION was made by Steve Bradshaw, seconded by Mereda Davis Johnson and passed 7-0-0-0 to approve Change Order No. 1 to Contract No. 14-902807 for Ethernet Dedicated Internet (Multi-year Contract), for use by the Department of Innovation and Technology (IT), with an amount not to exceed \$681,141.59.

ADOPTED: MAR 28 2017
(DATE)

PRESIDING OFFICER
DEKALB COUNTY BOARD OF
COMMISSIONERS

CERTIFIED: MAR 28 2017
(DATE)

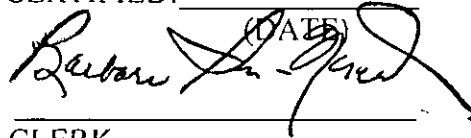
CLERK,
DEKALB COUNTY BOARD
OF COMMISSIONERS

FOR USE BY CHIEF EXECUTIVE OFFICER ONLY

APPROVED: APR 05 2017
(DATE)

CHIEF EXECUTIVE OFFICER
DEKALB COUNTY

VETOED: _____
(DATE)

CHIEF EXECUTIVE OFFICER
DEKALB COUNTY

VETO STATEMENT ATTACHED: _____

MINUTES:

FOR : Kathie Gannon, Steve Bradshaw, Gregory Adams, Nancy Jester, Larry Johnson, Mereda Davis Johnson, Jeff Rader

AGAINST : None

ABSTAIN : None

ABSENT : None

CHANGE ORDER

CO1. Change Order No. 1 to Contract No. 14-902807 for Ethernet Dedicated Internet (Multi-year Contract): for use by the Department of Innovation and Technology (IT). Awarded by the BOC on February 25, 2014 for an amount not to exceed \$247,768.20. This contract is a Master Service Agreement (MSA) that consists of the provision of Ethernet Dedicated Internet bandwidth and connectivity between all County buildings. The County will be moving from Dark Fiber to Lit Fiber to enhance services for all 175 County locations. The migration will occur one site at a time and each time a site is converted, the County will experience reduced costs. This request is for additional funds for Ethernet Dedicated Internet bandwidth, connectivity and the migration costs to switch from Dark Fiber to Lit Fiber. Recommend approval of Change Order No. 1 to increase the contract for an amount not to exceed by \$681,141.59 with:

Comcast Cable Communications Management, LLC, 1701 John F. Kennedy Blvd., Philadelphia, PA 19103

Amount Not To Exceed: \$681,141.59

and authorize the Chief Executive Officer to execute the change order and all associated documents.

Notes:

- | | |
|------------------------------|--------------------------|
| 1. Commission District(s): | All |
| 2. Contract Effective Date: | April 3, 2014 |
| 3. Contract Expiration Date: | March 31, 2019 |
| 4. Amount Spent to Date: | \$247,768.20 |
| 5. Funding: | General – Operating (IT) |

DEKALB COUNTY

ITEM NO.

BOARD OF COMMISSIONERS
BUSINESS AGENDA / MINUTES
MEETING DATE: March 28, 2017

HEARING TYPE
Preliminary

ACTION TYPE
RESOLUTION

SUBJECT: Motion to recess the meeting

DEPARTMENT: COUNTY CLERK
VIA & FAX

PUBLIC HEARING: YES
VIA & FAX NO

ATTACHMENT: No

INFORMATION CONTACT: Barbara H. Sanders-Norwood,
Clerk
404-371-2162

PAGES:

1

PHONE NUMBER:

PURPOSE:

To recess the meeting until 6:30 p.m.

NEED/IMPACT:

To allow the Commissioners to act on the items.

RECOMMENDATION(S):

To approve recessing the meeting.

VIA & FAX



FOR USE BY COMMISSION OFFICE/CLERK ONLY

ACTION : 2017-03-28 Recess

MOTION was made by Jeff Rader, seconded by Gregory Adams and passed 7-0-0-0 to Recess until 6:30pm.

ADOPTED: MAR 28 2017
(DATE)

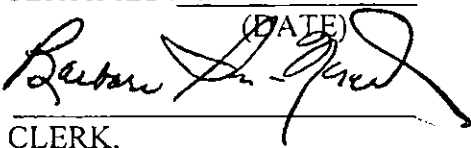
CERTIFIED: MAR 28 2017
(DATE)

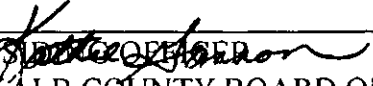
CLERK,
DEKALB COUNTY BOARD
OF COMMISSIONERS

PRESIDENT
DEKALB COUNTY BOARD OF
COMMISSIONERS

FOR USE BY CHIEF EXECUTIVE OFFICER ONLY

APPROVED: APR 05 2017
(DATE)

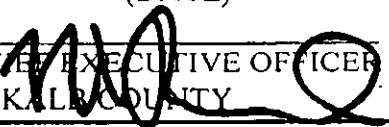
VETOED: _____
(DATE)

CHIEF EXECUTIVE OFFICER
DEKALB COUNTY

CHIEF EXECUTIVE OFFICER
DEKALB COUNTY

VETO STATEMENT ATTACHED: _____

MINUTES:

- FOR : Kathie Gannon, Steve Bradshaw, Gregory Adams, Nancy Jester, Larry Johnson, Mereda Davis Johnson, Jeff Rader
- AGAINST : None
- ABSTAIN : None
- ABSENT : None