

Sole Source - PWTech Volute™ Dewatering Screw Press System

User Department's Recommendation

User Department Name: Watershed Management - CIP

Recommended Bidder(s) meets our approval.

Bidder 1: PWTech/ \$1,584,280.00
Name/Amount

Project Amount This Term: \$ 1,584,280.00

Funding: Renewal & Extension (R&E)

General **Enterprise** **3 Digit Fund Code** 513

CIP Line Item No. (if applicable): 54

Sole Source - PWTech Volute™ Dewatering Screw Press System

Justification:

DWM's Pole Bridge wastewater treatment facility must procure a sludge dewatering system to process all sludge at the facility. DWM, completed an extensive study that included multiple trials in order to conclude the best product for this project. Pole Bridge has several physical restrictions that limit the facility to the selected product. Restrictions included equipment performance, space and power supply restrictions, water consumption, maintenance requirements, and equipment accessibility.

The equipment performance restrictions demands that the technology must be able to consistently dewater the aerobically digested waste activated sludge at the Pole Bridge to an acceptable concentration, while consuming the minimum amount of chemicals, water, and electricity. The equipment and all components must be able to fit into the existing building while allowing space for personnel to perform all necessary maintenance. The equipment must be able to fully function using the existing power supply at the site. The equipment must not use more than 1000 gallons of wash water per day based on an 8 hours per day. DeKalb staff must be able to service and repair the device without the need of specialty tools and equipment such as overhead cranes. DWM requires the equipment to be made in the USA. It is also required for spare parts and service technicians to originate and ship from within the US only. The proposed equipment model must have the reference in operation with the same type of the sludge at Pole Bridge.

Technologies that were considered are Centrifuge, Belt press, rotary press, Screw press and the Bucher press. Of these Technologies, the Screw press performed to standard. However, PWTech is the only system that can accommodate the Space restrictions, water restrictions, power restrictions, performance requirements and reference of the proposed model.

Kerry Williams,
P.E., PMP

Digitally signed by Kerry Williams, P.E., PMP
DN: cn=Kerry Williams, P.E., PMP, o=DeKalb
County, ou=ECMS,
email=kwilliams@dekalbcountyga.gov, c=US
Date: 2020.10.15 15:56:48 -0400

Kerry Williams,
Engineer Manager

Date

Reginald Wells

Digitally signed by Reginald
Wells
Date: 2020.10.19 13:41:12
-04'00' 10/19/2020

Reginald D. Wells, Director,
Department of Watershed
Management

Date



Department of Purchasing and Contracting

INSTRUCTIONS FOR NON-COMPETITIVE PURCHASE REQUESTS

The Competitive Bidding Process is the preferred method of purchasing good or services. A waiver of this process must be requested on a case by case basis by completing a Non-Competitive Purchase Request Form in its entirety.

The form must be signed by Department Director of the User Department and submitted to the Director of the Department of Purchasing and Contracting by attachment to the requisition in Oracle.

Justification for the waiver must be provided on the request form. Additional pages may be attached if necessary.

Non-Competitive Purchase Requisitions must have a market/price reasonableness determination.

Emergency Purchase Request

An Emergency Purchase Request is to be used when a User Department seeks goods or services due to an unexpected and urgent request where health and safety or the conservation of public resources is at risk. The request must be completed regardless of the time of the emergency occurrence or dollar amount of the requisition, and must include an explanation as to why the emergency cannot be responded to using the competitive process. Expiration of funds, administrative delay or expiration of a contract or quote is not acceptable criteria for an Emergency Non-Competitive Purchase.

An emergency procurement is handled outside of the normal competitive process because of the urgency of the circumstances. **Poor planning or the pending expiration of funds does not constitute a valid justification for an emergency purchase.**

Sole Source Purchase Request

A Sole Source Purchase Request is to be used when a User Department seeks goods or services from the only qualified vendor or supplier that possesses the unique ability or available capacity to provide the requested goods or services. A vendor may be a sole source when the procurement involves proprietary technology, copyright, or patented information, goods or services. Additional justification for a Sole Source Purchase Request may include the requirement to match piece of existing equipment available only from the same source of original equipment or authorized dealer or an upgrade to existing software only available from the producer of the software;

A Sole Source Public Notice Form shall be posted on the County's website for five (5) business days and the results shall be attached to this Sole Source Purchase Request.



Department of Purchasing and Contracting NON-COMPETITIVE PROCUREMENT REQUEST FORM

Requesting Department: Watershed Department
Department Contact Person: Tina Strickland Telephone: 770 4142385
Email: tstrickland@dekalbcountyga.gov

Requisition Number: _____ Suggested Supplier: PW Tech
Estimated Amount of Purchase: \$ 1,584,280.00
Detailed Description of the Goods or Services to be purchased: See details in the attachment.

Emergency (For Emergency Requests, Please check this box and answer **all** questions below.)

1. Date and Time of Emergency Occurrence: _____

2. Please state the nature of the emergency posing a risk to public health, welfare, safety or resources:

3. State how the Estimated Amount was determined to be Fair and Reasonable (attach supporting documentation):

Sole Source (Please check box and answer all of the following completely.)

1. Provide an explanation why the product, service or supplier requested is the only method that can satisfy the requirements. Please explain why alternatives are unacceptable. Be specific with regard to specification, features, characteristics, requirements, capabilities and compatibility. (Attach additional documents, if necessary):

Due to the limited space, power supply and low maintenance, two PW Tech Screw Presses Model ES-354 can be able to satisfy under these conditions. Furthermore, PW Tech can provide the higher % sludge dryness (SD) between 17-20% than the belt filter which is currently operated at 15% SD.

2. Will this purchase obligate us to a particular vendor for future purchases? (Either in terms of maintenance that only this vendor will be able to perform and/or if we purchase this item, will we need more "like" items in the future to match this one?) Explain in detail.

Some parts that will be required from the same vendor such as the screw press however this is very rare occasion that the screw press will need to be replaced besides it is broken.

3. Explain the impact to the County or Public if this request is not approved.

The county has to keep continue hiring the contractor, currently contract with Denali, to dewatering the sludge as the premium cost. In order to save the cost for the county, this would be better to buy and has it own dewatering equipment.

I hereby request that this non-competitive procurement request be approved for the purchase of the above stated work, material, equipment, commodity, or service.

Department Director (Typed/Printed Name) _____ Signature: Reginald Wells Digitally signed by Reginald Wells Date: 2020.12.01 11:47:40 -0500 Date: 12/01/21

Do Not Write Below – for the Department of Purchasing and Contracting Use Only

Procurement Agent (Typed/Printed Name) _____ Signature: Willie Moon Digitally signed by Willie Moon Date: 2020.12.17 22:02:43 -0500 Date: 12/17/21
See Agent Recommendation

Procurement Manager (Typed/Printed Name) _____ Signature: _____ Date: _____

Approved Not Approved

Signature: _____, Director, Department of Purchasing and Contracting Date: _____

(Additional information, attach pages if required):

16 November, 2020



RE: PWTech Volute™ Dewatering Press Sole Sourcing for DeKalb County

Dear Mr. Willie Moon,

Process Wastewater Technologies, LLC, (PWTech) is the sole source for the Volute™ Dewatering Press in the United States. The Volute™ Dewatering Press was invented, patented and trademarked by Amcon, Inc. and licensed to PWTech for exclusive manufacture and sale in the United States.

In addition, PWTech has demonstrated multiple unique characteristics of the Volute™ Dewatering Press as manufactured by PWTech that cannot be duplicated by conventional screw presses, to include the following:

- The model ES-354 Volute™ press will fit within the existing building without requiring any modifications to the building structure, while still permitting the majority of the building to be used for consumables storage and other equipment.
- If desired, sufficient space remains for a second ES-354 or similar model Volute™ press to be installed at a future date, again while permitting the majority of the building to be used for consumables storage and other equipment.
- All installation and maintenance can be conducted with on-hand equipment. No heavy equipment beyond the plant's medium-duty forklift is required to unload and place the Volute™ press. Crane rental is not required to unload or maintain the Volute™ press, unlike physically larger conventional screw presses of similar capacity.
- The ES-354 Volute™ press uses four redundant dewatering drums. As demonstrated by PWTech field engineers during pilot testing, drums can be removed or installed in as little as 20 minutes, allowing the press to continue running at 75% capacity even while being serviced.
- The alternating fixed and moving ring design of the Volute™ press creates a dewatering drum that mechanically clears itself during operation. Continuous washdown is not required. Unlike conventional belt and screw presses, the Volute™ is functionally immune to blinding due to fats, oils and greases (FOG), permitting it to be used for other feeds at the plant.
- PWTech has conducted a full-scale pilot study. Because of the compact nature of the Volute™ press, performance is not estimated from a smaller demonstration unit, it is shown at the same scale as the proposed system.
- PWTech's patent-pending controls upgrade to the Volute™ press, standard on all new units since 2019, provides chemical dosing accuracy that is typically accurate within 1% using a progressive cavity pump while allowing the press to automatically vary feed rates to reduce consumables consumption, disposal costs, and maximize throughput during unattended operation.
- Through partnership with Kazmier and Associates, Inc., PWTech can provide local technical support for the Volute™ press within 50 miles of the Pole Bridge Creek Advanced Wastewater Facility.

We thank you for your interest in the Volute™ Dewatering Press and look forward to answering any questions you may have regarding the above. If you require additional information, please do not hesitate to contact me at 410-238-7977 or rhunt@pwtech.us.

Respectfully,

A handwritten signature in cursive script that reads "Rich Hunt".

Rich Hunt
Regional Manager, Southeast U.S.
Process Wastewater Technologies LLC.



PROPOSAL

PROCESS WASTEWATER TECHNOLOGIES, LLC. | 9004 Yellow Brick Rd, Suite. D, Rosedale, MD, 21237
Phone: 410 238 7977 | Facsimile: 410 238 7559 | Email: rhunt@PWTech.us | Web: www.PWTech.us

| | |
|--|--|
| PROJECT / REF: Pole Bridge AWWT, DeKalb, GA | |
| TO: Willie Moon, CPPB wmoon@dekalbcountyga.gov | DATE: 16 November, 2020 |
| COMPANY: DeKalb County | PWT #: VDP-GA-18132 |
| ADDRESS: 1300 Commerce Drive, 2nd Floor Decatur, GA 30030 | REV: 10 |
| | REP: Jason Bott |
| | FIRM: Kazmier & Associates |
| | CONTACT: jason@kazmierinc.com |
| SUBJECT: Price and Scope for two (2) Volute* Dewatering Presses model ES-354 and appurtenances for Pole Bridge AWWT | |
| SIZING: Sized as per request | |
| REV. NOTES Bonding revised for only the construction portion of the project | |
| NOTES: Volute press notes are per each system. Maximum throughput demonstrated on ES-350 Volute Dewatering Drum was 55 GPM @ 2.4% solids. Proposed capacity at maximum throughput is eight (8) drums, total of 440 GPM. | |

Scope of supply:

- Two (2) Volute* Dewatering Press – PWTech® Model ES-354 unit
- Two (2) Polymer Preparation System - VeloDyne Model VeloBlend VM-15P-1800-X0D
- Two (2) Sludge Feed Pump - Seepex BN 130-6LS
- Two (2) Polymer Feed Pump – Seepex BN 10-6LS
- Two (2) Influent Sludge flowmeter - Rosemount™ Model 8750W with 4" ANSI Flange connections
- Two (2) Polymer Feed flowmeter - Rosemount™ Model 8750W with 1" ANSI Flange connections
- Two (2) 1700 gallon DuraCast HDPE 942 polymer tanks (1x aging/day tank, 1x neat polymer storage tank)
- One (1) Ultra-Tech modular hard-sided containment wall systems with liner, 15'x15', EPA 40 CFR 264.175 approved with above tanks.
- One (1) U350 (14") Spirac loadout shaftless screw conveyor
- One (1) U420 (16") Spirac elevation shaftless screw conveyor
- One (1) Total Solids Meter – Valmet TS FT-100/4" microwave in-line solids meter
- Two (2) Microwave Dry Solids Analyzer, Valmet DS
- One (1) Control System for the above
- Documentation (Submittals and O&M Manuals)
- Start-up and commissioning services
- Delivery to site

*Volute is registered with the U.S. Patent and Trademark Office as a registered trademark of AMCON, Inc., Yokohama, Japan



Notes on Volute Dewatering Press, PWTech® Model ES-354

Base unit supply

- The unit to be supplied will be an ES-354 with a MAXIMUM capacity of approximately 220 GPM at 2.4% feed solids
- Each ES-354 Volute Dewatering Press consists of:
 - Flash mixing tank including gear motor and tilted blade impeller mixer
 - Flocculation tank including gear motor and large cross-sectional area impeller
 - Four (4) x ES350 Series Volute Dewatering Drums, each with a drive motor
 - Filtrate collection pan and support frame.
 - Integrated, pre-wired control panel for the unit and appurtenances mounted on the flocculation tank. (may be provided mounted separately if requested).
 - 4" flanged inlet and 6" flanged outlet

Construction

- The unit is all stainless steel. No carbon steel is used in the manufacture of the press.
- Unit is manufactured and assembled in the USA. All components are sourced from the USA or Japan.
- Electrical components are manufactured and tested prior to shipment to site in the United States.
- Mixing tank gear drives are Brother GTR gear motors utilizing hypoid and helical-bevel gear reduction, one piece construction and are sealed for life.
- Dewatering drum gear drives are SEW Eurodrive gear motors utilizing helical gear reduction.

Supplied spare parts

- No spare parts are included in the quoted price.

Notes on Polymer Prep. System - VeloDyne Model VeloBlend VM-15P-1800-X0D

Polymer preparation system consists of the following components:

Polymer Mixing Chamber

- A high energy, multi-zoned, hydro-mechanical mixing device designed to effectively activate, dilute and mix polymer and dilution water utilizing an impeller designed to produce variable intensity, back-flow mixing action to optimize polymer performance without damage to the polymer's molecular structure.
- Mixer Motor: ½ HP, 90 VDC, 1750 RPM, Wash-Down Duty with keyless shaft and left hand impeller mounting screw
- Mechanical Mixer Shaft Seal and Seal Flushing Assembly with Orifice Plate
- Velo-Check® neat polymer poppet style check valve specifically designed to isolate neat polymer and dilution water. The check valve shall be held in place by a quick release pin for easy assembly and disassembly
- Materials of construction are SS304 and Lexan (Body), Viton, SS304 and ceramic (Seals) and SS304
- Pressure Rating: 100 psi

Neat Polymer Metering Pump

- A stainless steel & Viton 15GPH progressive cavity metering pump shall be provided
- ½ HP, 2500 RPM, 90 VDC, TEFC Motor
- Thermal type loss of polymer flow sensor
- Metering pump calibration assembly with isolation valves: (1000 ml)



Dilution Water Inlet and Solution Outlet Assembly

- Primary 180-1800 GPH controllable dilution water flow
- 1" FNPT water inlet connection with Dilution Water ON/OFF Solenoid Valve
- Low differential pressure alarm switch
- 0-160 psi inlet water pressure gauge (stainless steel, liquid filled)

Construction

- Frame and fasteners are 304 stainless steel. Frame is open design for access to all components and is designed for bolt-down installation.

Notes on Seepex BN 130-6LS Sludge Feed Pump

Performance data

- | | | | | |
|---------------------------------------|-----------|----------|----------|--------|
| • Minimum design flow: | 66 USGPM | @15 psi, | @61 rpm | @11 Hz |
| • Normal design flow: | 220 UGPM | @15 psi, | @140 rpm | @35 Hz |
| • Maximum design flow: | 330 USGPM | @15 psi, | @210 rpm | @52 Hz |
| • Starting torque: | 686 lb.ft | | | |
| • Max. running power absorbed: | 8.75 hp | | | |
| • Discharge pressure: | 15 psi | | | |
| • Differential pressure: | 15 psi | | | |

Design

- 25 HP Drive for pump
- Mechanical components are 316 SS
- Single-acting mechanical seal
- Pump includes run-dry protection

Notes on Spirac conveyor system

Design

- Loading = 500 cubic feet per hour
- Length and sizing subject to minor revision based on appropriate layout for discharge into solids transport dump trucks or trailers

Construction

- **U-Trough:** 10ga - 304SS
- **Trough Lids:** 10ga - 304SS (Bolted / 5ft max with neoprene gasketing)
- **Trough Liners:** DURAFLO type SPX min 5/8 in thick UHMWPE, maximum 4ft lengths
- **Spiral:** AB Spiral High Tensile Micro Alloy Steel (HTMAS), 225 Brinnell
- **Drive End:** SEW model FA77 parallel shaft gearbox with SS end cap and hollowshaft mounting or Similar and 4140CRS driveshaft, bell housing with pressure greased packing gland

Electrical components, per conveyor:

- One (1) Emergency stop switch c/w cable, mounting hardware, 120VAC NEMA 4
- One (1) Loss of rotation (LOR) sensor model MSP-12 + MSA-4P alarm/control panel NEMA 4



Conveyor #1, Spirac U350

- 25 foot approximate length
- Horizontal configuration
- Two (1) rectangular inlet
- One (1) rectangular outlet
- 7.5 HP Drive

Conveyor #2, Spirac U420

- 34 foot approximate length
- Inclined configuration, approximately 25° (up to 30°)
- One (1) rectangular inlet
- One (1) rectangular outlet
- 10 HP Drive

Notes on Magnetic flowmeter, Rosemount™ Model 8750W

- 4 inch ANSI 150# flange connections. (sludge feed)
- 1 inch ANSI 150# flange connections. (polymer feed)
- Coated Carbon Steel construction with a polyurethane, ceramic, neoprene, or Teflon liner as required by the application.
- All metallic wetted parts are stainless steel type 316
- Suitable for direct burial and constant flooding (IP 68) with remote transmitter.
- Includes grounding rings
- Flowmeter outputs analog signal (4-20 mA) to Volute* Press Control panel

Notes on Microwave Total Solids Analyzer, Valmet TS FT-100/4”

- 4 inch flangeless connections
- Stainless steel sensor housing with EPDM seals
- All metallic wetted parts are stainless steel type 316 or 316L
- 0-40% dry solids measuring range
- ± 0.01 % TS repeatability
- TS Analyzer outputs analog signal (4-20 mA) to Volute* Press Control panel for improved polymer dose control

Notes on Microwave Resonance Dry Solids Cake Analyzer, Valmet DS

- Mounted on customized Volute* cake chute
- 10” length cake sampling auger
- 316 Stainless steel, ceramic and high density PE construction
- 15-35% total solids measuring range
- DS Analyzer outputs analog signal (4-20 mA) to Volute* Press Control panel for improved cake solids control



Notes on Electrical and Control

The Volute* unit is supplied with a pre-mounted, pre-wired control panel designed to control all aspects of the thickening/dewatering operation unless otherwise specified and noted.

- Panel is fed by a single 208, 240, or 480VAC, 3-phase, 60 Hz, power supply (client specified)
- Control panel is NEMA 4X rated manufactured in Stainless Steel type 304
- Control Panel is manufactured in a UL accredited facility and is UL Listed
- Panel includes HMI and PLC control modules. Unless specified otherwise, PLC/HMI is a single Unitronics UniStream 15.6" HMI+PLC. Allen Bradley CompactLogix PLC and PanelView HMI may be substituted upon request at no additional charge.
- All manual switching operations are undertaken via switches on the HMI
- Unit includes complete control system for unit and ancillary equipment including operation of the polymer preparation system and VFD control for feed pump.
- Control system may utilize a system flow meter (not included in this proposal unless specifically noted in the scope) and PID loop to allow operator to set the system flow.
- System may include interlocks for Conveyor start-up, shut down and E-stop if required
- Control panel includes system running and system fault outputs to plant PLC and the ability to connect via Ethernet (ModBus TCP/IP) to external controls.
- A junction box on the polymer preparation skid is pre-wired to the polymer preparation components and designed for easy on-site connection to the main Volute* system control panel.
- Junction box is NEMA 4X FRP and includes numbered terminal block & wires with terminal block legend.

General Notes

Documentation:

Scope includes:

- Submittals (hard copy and electronic) and
- O&M Manuals (hard copy and electronic).
- PLC/HMI Program (but not programming software)

Start-up services:

Scope includes the following start-up services -

- On-site start-up and training services for four (4) consecutive days (8 hours per day, Monday-Friday) by a PWT field service engineer and/or manufacturer's representative
- Services include:
 - Installation inspection
 - Commissioning of Volute* unit and Controls
 - Start-up of Ancillary equipment included in this Scope
 - Functional testing and calibration of equipment
 - Training on all equipment
- Phone consultation regarding installation will also be provided.
- Should additional services be deemed necessary by the PURCHASER, the additional services can be procured from PWT on a per diem basis. The current rate is \$1000 per day plus travel.

Items not included in this proposal unless explicitly stated

- Taxes, permits and bonding
- Any civil works including, but not limited to, any building works, construction of suitable foundations, and access structures.
- Installation including, but not limited to, mechanical, plumbing, and electrical hook-ups
- Unloading on site and storage



- PLC/HMI Programming software unless specified elsewhere.

Delivery and Freight

- Submittals issued approximately six (6) weeks from receipt of written Purchase Order
- Delivery is approx. eighteen (18) weeks from receipt of written acceptance of Submittal documents
- Deliver to site for all components **is INCLUDED in the price.**

Governing Terms and Conditions and Warranty

- This scope is subject to Process Wastewater Technologies, LLC. Standard Terms and Conditions and Standard Warranty as attached with the exception of the following:
 - Warranty extended to two years from shipment

PRICE

| | |
|--|---------------------------|
| Two (2) PWTech ES-354 Volute Dewatering Press, with | \$1,075,840.00 |
| Two (2) VM-15P-1800-X0D Velodyne VeloBlend polymer makedown skid | |
| Two (2) Sludge Feed flowmeter - Rosemount™ Model 8750W with 4" ANSI Flange connections | |
| Two (2) Sludge feed pump – Seepex BN 130-6LS | \$72,700.00 |
| Two (2) Spirac Shaftless Screw Conveyor | \$133,000.00 |
| One (1) Valmet solids measuring & control system | \$137,000.00 |
| One (1) Polymer feed & aging tank system, to include: | \$36,500.00 |
| Two (2) 1700 gallon DuraCast HDPE 942 polymer tank or similar | |
| Two (2) Seepex BN 10-6LS diluted polymer feed pumps | |
| Two (2) Polymer Feed flowmeter - Rosemount™ Model 8750W with 1" ANSI Flange connections | |
| One (1) UltraTech Ultra-Containment Wall system, 15'x15'x3' | |
| Turn-key installation, to include unloading, mechanical, plumbing & electrical hook-ups | \$129,240.00 |
| 100% Performance bond and 100% Payment bond IS included for installation | |
| Total price for Two (2) Volute Presses and appurtenances as per this proposal: | \$1,584,280.00 |

*Volute is registered with the U.S. Patent and Trademark Office as a registered trademark of AMCON, Inc., Yokohama, Japan



Volute Dewatering Press Specification Sheet - ES354

| | | | | |
|---------------------|----------------------------------|--|---------------------------------|------------|
| General Data | Model Information | Model: | ES354 | |
| | | Over All Dimensions: | 217" x 123" x 88" (L x W x H) | |
| | | Optimal Space requirement of installation: | 276" x 207" (L x W) | |
| | | Minimum Opening dimensions for installation: | 60" x 60" (min. 81" x 89" rec.) | |
| | | Weight | Empty: | 10,940 lbs |
| | | | Operating: | 16,370 lbs |
| | | MAX Solids throughput (Solids >4%): | 2800 Dry pounds per hour | |
| | | MAX Hydraulic throughput (Solids <1%): | 265 GPM | |
| | | Maximum Power Use: | 12 HP (~7 HP typ.) | |
| Washwater use: | 12GPM intermittent, 60 GPH total | | | |

| | | | | |
|------------------------|-------------------|----------------------|----------------------------|---------------------------------------|
| Dewatering Drum | General | Dimension: | 13.75" diameter x 72" long | |
| | | Quantity: | 4 | |
| | | Material: | Thickening Zone: | Type 304 Stainless Steel |
| | | | Dewatering Zone: | Type 304 Stainless Steel |
| | | | Screw: | 304 Stainless Steel with CoCr coating |
| | Drive info | Gear Motor Supplier: | SEW Eurodrive | |
| | | Model: | KH97R57DRN90L4-504 | |
| | | Motor Power: | 1.5 kW (2.0HP) 4-Pole | |
| | | Insulation: | TEFC / IP55 | |
| | | Gear Reduction: | 504:1 | |

| | | | |
|---------------------------|-------------------|----------------------|-----------------------------|
| Flash mixing tanks | General | Dimensions: | 36" x 51" x 49" (L x W x H) |
| | | Volume | 382.9 Gallons |
| | | Working Volume: | 336 Gallons |
| | | Material | Type 304 Stainless Steel |
| | Drive Info | Gear Motor Supplier: | Brother |
| | | Model: | F3S35S15-WV6AWN |
| | | Motor Power: | 0.8 kW (1 HP) 4-Pole |
| | | Motor Insulation: | TEFC / IP65 |
| | | Gear Reduction: | 15 : 1 |

| | | | |
|--------------------------|-------------------|----------------------|-----------------------------|
| Flocculation tank | General | Dimensions: | 51" x 51" x 49" (L x W x H) |
| | | Volume | 551.6 Gallons |
| | | Working Volume: | 484.1 Gallons |
| | | Material | Type 304 Stainless Steel |
| | Drive Info | Gear Motor Supplier: | Brother |
| | | Model: | F3S50S60-WV9AWN |
| | | Motor Power: | 2.2kW (3.0HP) 4-Pole |
| | | Motor Insulation: | TEFC / IP65 |
| | Gear Reduction: | 60 : 1 | |

| | | | |
|-------------------|----------------|---------------------------------|--------------------------------|
| Electrical | General | Supply Voltage: | 208/240/440/480 VAC |
| | | Service: | 3-Phase, 3-Wire (No Neutral) |
| | | Control Voltage: | Dual - 24VDC & 115VAC |
| | | Minimum Required Breaker Size:* | 40 Amps * 480 VAC |
| | Panel | Panel Size: | 48"(w) x 48"(h) x 12"(d) |
| | | Panel Material: | 304 Stainless Steel |
| | | Panel Rating: | NEMA 4X |
| | | Control Module: | Unitronics UniStream 15.6" PLC |

| | | |
|-----------------------|------------------------|-----------------------------------|
| Polymer System | Supplier: | Velocity Dynamics, Inc. |
| | Model: | VM-15P-1800-X0D |
| | Mixing Type: | Variable - Mechanical & Hydraulic |
| | Feed Pump Type: | Progressive Cavity |
| | Polymer Feed Capacity: | 0.75 - 15 Gallons per hour |
| | Water Use: | 180 - 1800 Gallons per hour |
| | Dimensions: | 24" x 34" x 42" (L x W x H) |
| | Weight: | ~300 lbs |

| | | |
|--------------------|---------------------------|-------------------------|
| Connections | Feed Sludge: | 4" ANSI 150# Flange |
| | Filtrate: | 2 x 6" ANSI 150# Flange |
| | Drain: | 3" ANSI 150# Flange |
| | Water: | 3/4" FNPT Coupling |
| | Polymer Water Inlet: | 1" FNPT |
| | Polymer Solutions Outlet: | 1"FNPT |
| | Raw Polymer Feed Inlet: | 1"FNPT |

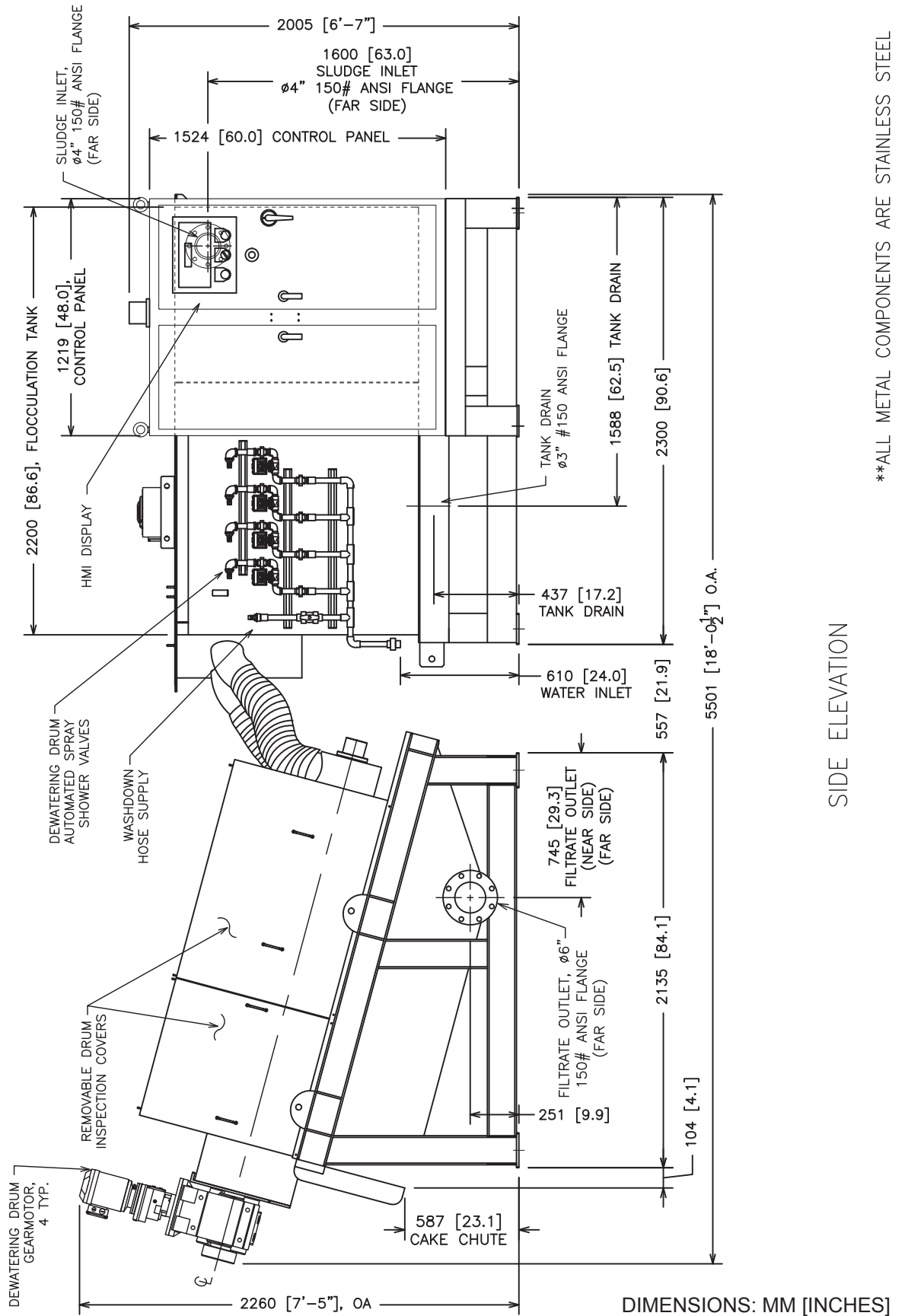

**ALL METAL COMPONENTS ARE STAINLESS STEEL

SIDE ELEVATION



VOLUTE DEWATERING PRESS
 ES-354 GA DRAWING
 ELEVATION VIEW

| | |
|----------------------|--------|
| JOB# PWT VDP ES-354 | SCALE |
| DATE 7 JANUARY, 2019 | NTS |
| DRAWN PWTech LLC. | SHEET |
| APPROV. RICH HUNT | 1 OF 7 |

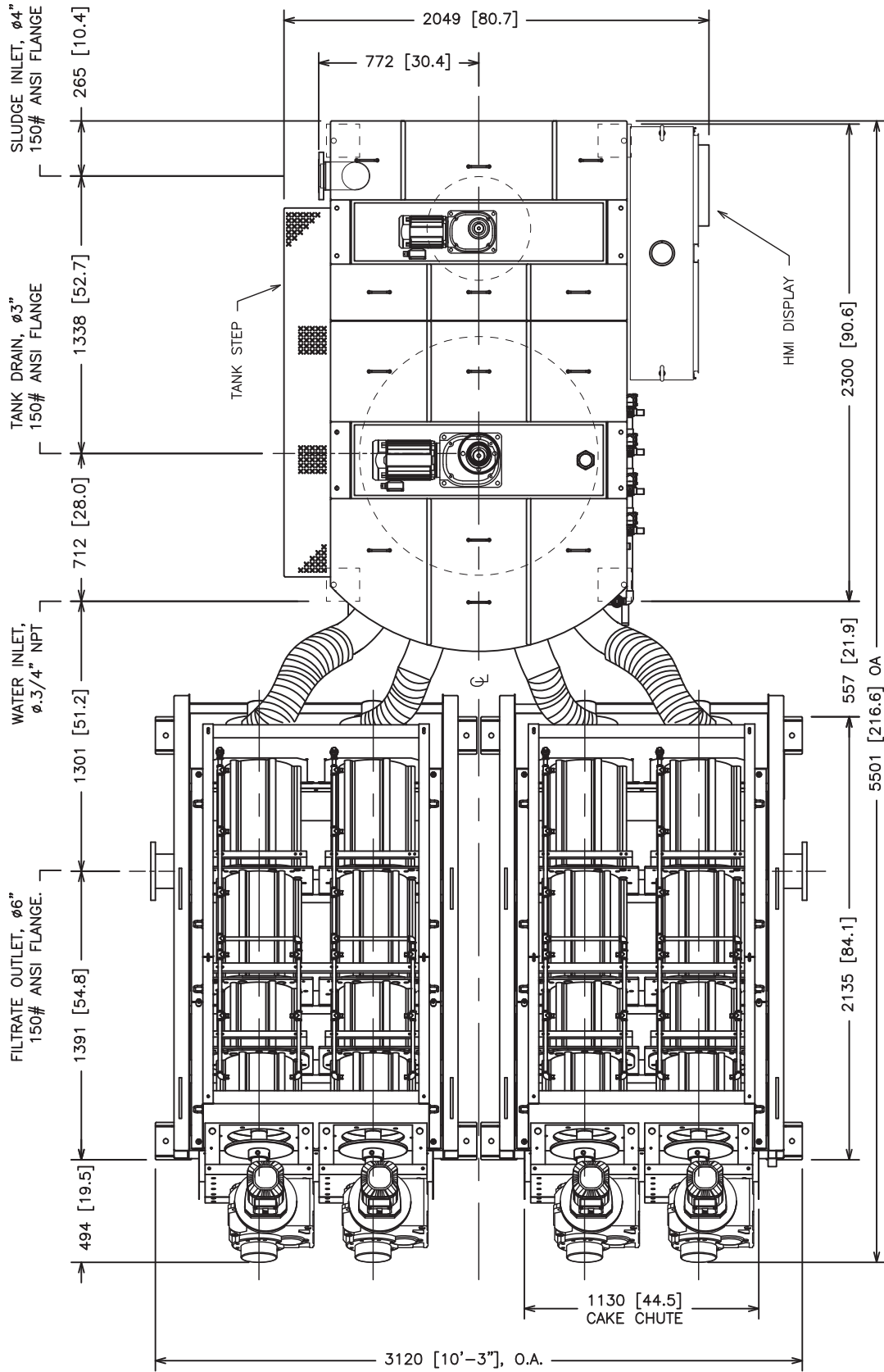

DIMENSIONS: MM [INCHES]

PLAN VIEW

**ALL METAL COMPONENTS ARE STAINLESS STEEL



VOLUTE DEWATERING PRESS
ES-354 GA DRAWING
PLAN VIEW

JOB# PWT VDP ES-354
DATE 7 JANUARY, 2019
DRAWN PWTech LLC.
APPROV. RICH HUNT

SCALE
NTS
SHEET
2 OF 7

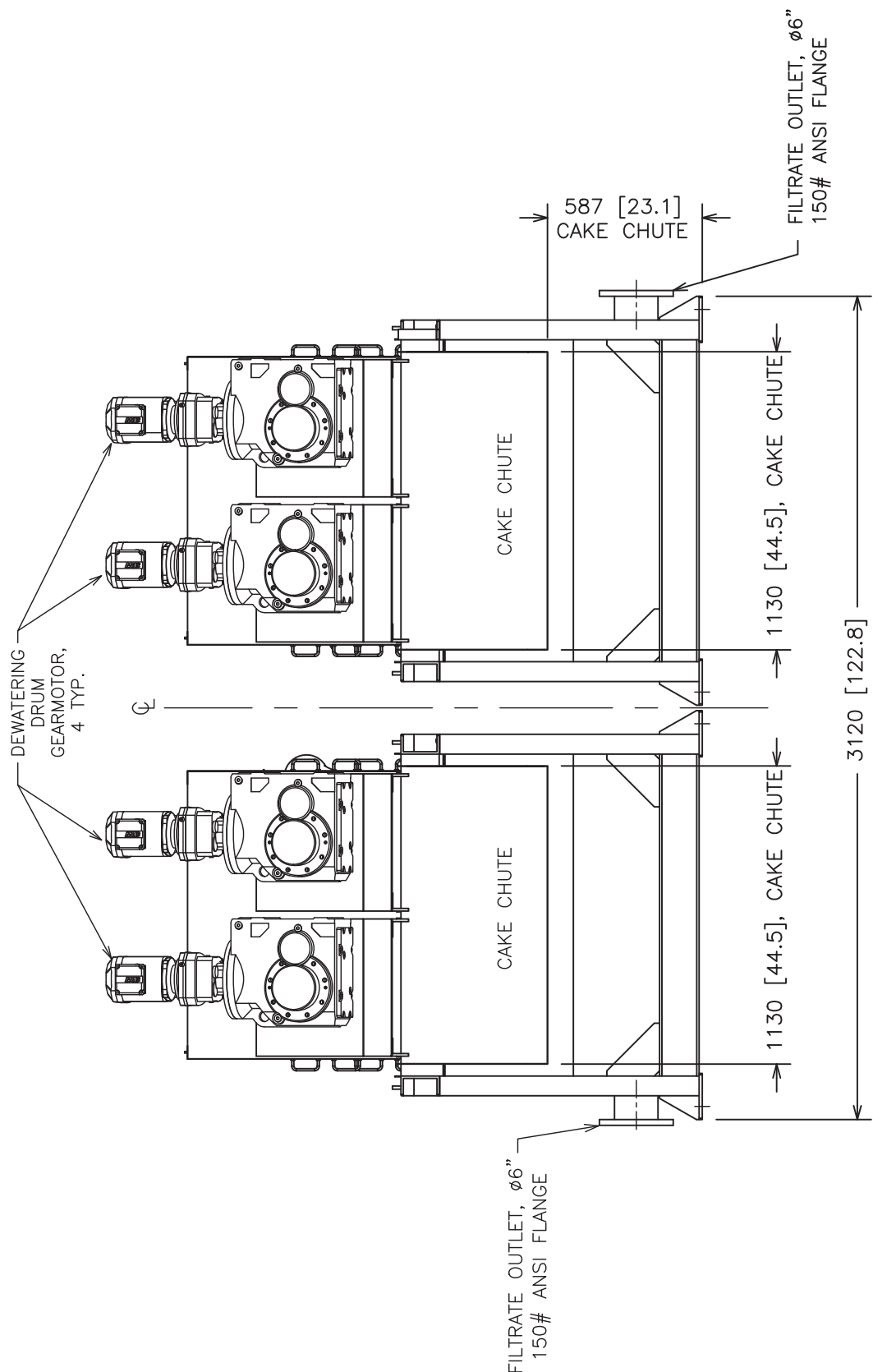

PRESS END ELEVATION

**ALL METAL COMPONENTS ARE STAINLESS STEEL

DIMENSIONS: MM [INCHES]



VOLUTE DEWATERING PRESS
 ES-354 GA DRAWING
 END ELEVATION

| | |
|----------------------|--------|
| JOB# PWT VDP ES-354 | SCALE |
| DATE 7 JANUARY, 2019 | NTS |
| DRAWN PWTech LLC. | SHEET |
| APPROV. RICH HUNT | 3 OF 7 |

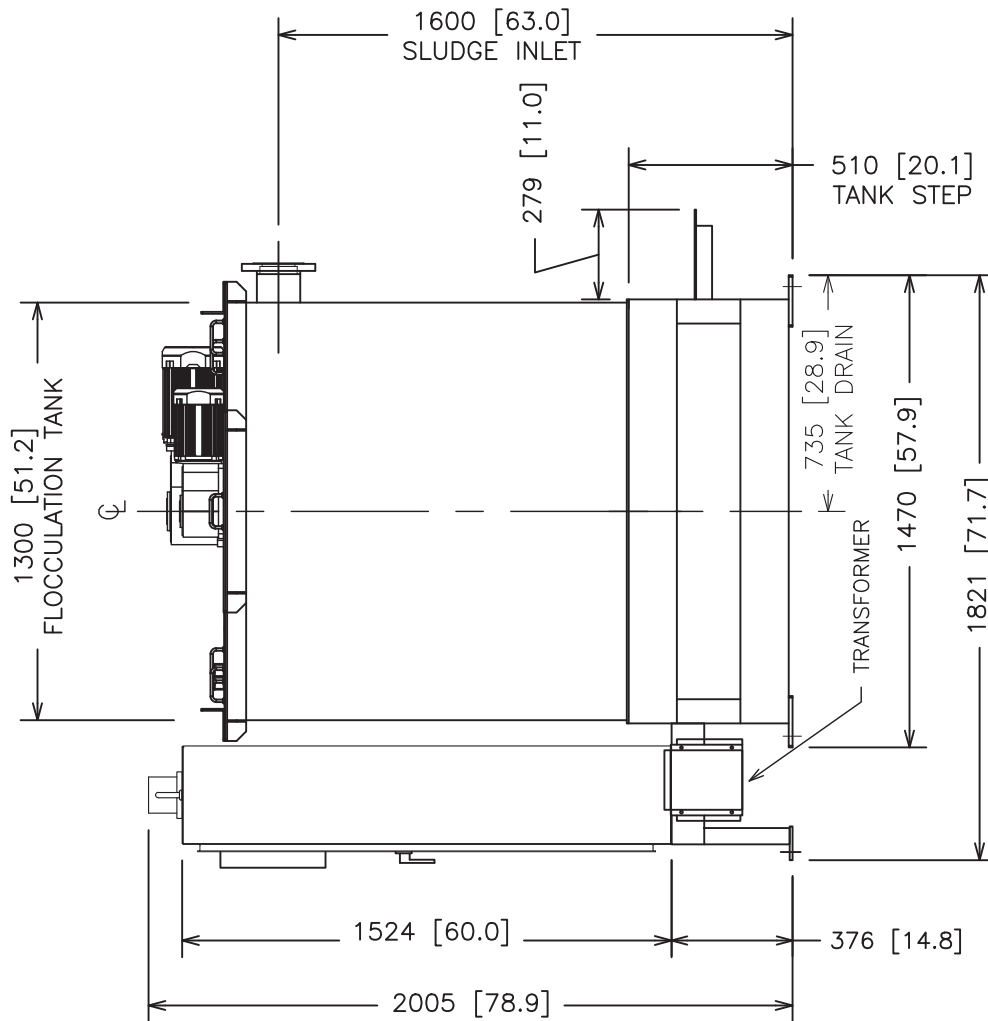

TANK END ELEVATION

**ALL METAL COMPONENTS ARE STAINLESS STEEL

DIMENSIONS: MM [INCHES]



VOLUTE DEWATERING PRESS
ES-354 GA DRAWING
END ELEVATION

| | |
|----------------------|--------|
| JOB# PWT VDP ES-354 | SCALE |
| DATE 7 JANUARY, 2019 | NTS |
| DRAWN PWTech LLC. | SHEET |
| APPROV. RICH HUNT | 4 OF 7 |

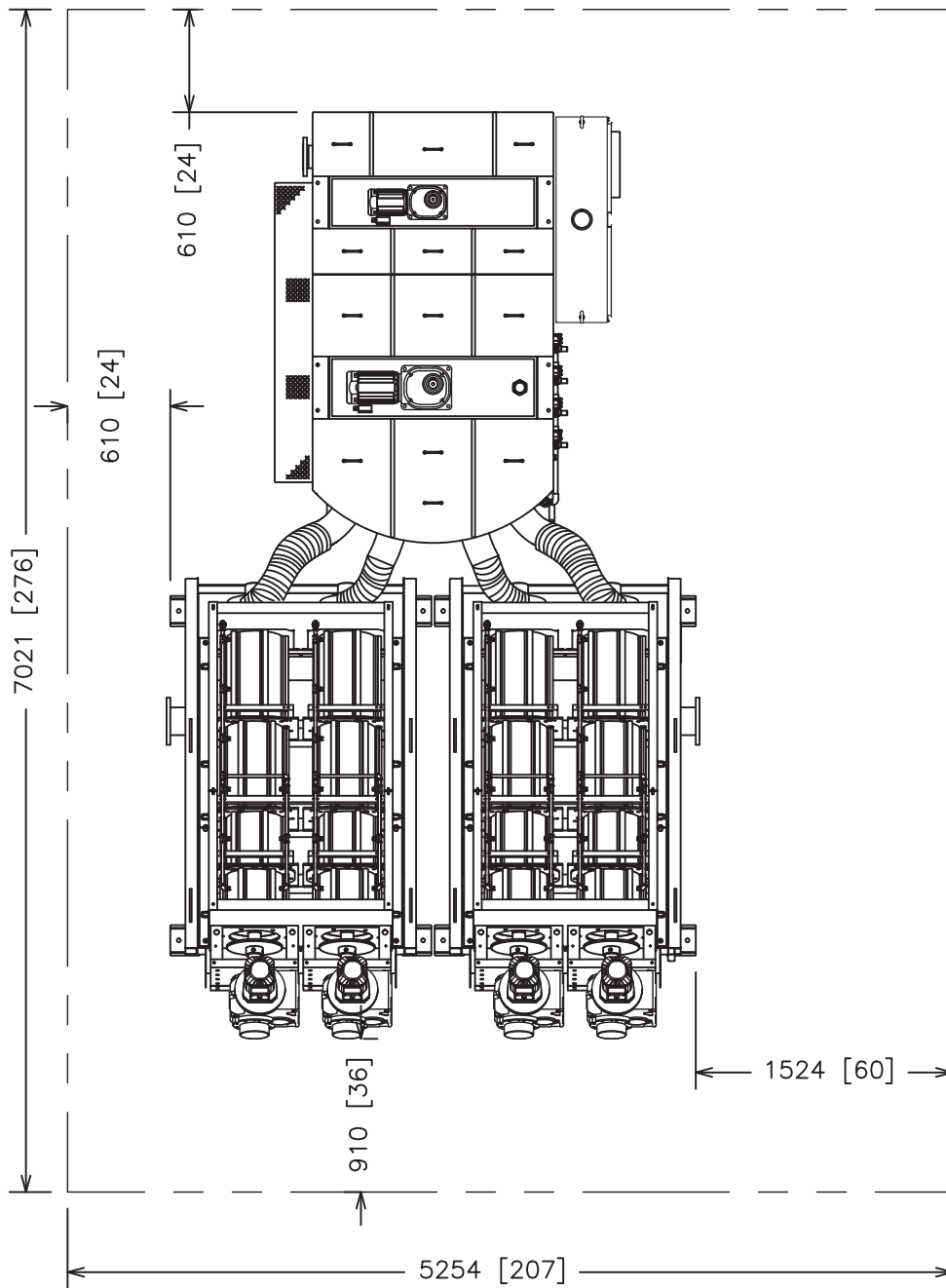

RECOMMENDED SPACE

DIMENSIONS: MM [INCHES]



VOLUTE DEWATERING PRESS
 ES-354 GA DRAWING
 RECOMMENDED SPACE

| | |
|----------------------|--------|
| JOB# PWT VDP ES-354 | SCALE |
| DATE 7 JANUARY, 2019 | NTS |
| DRAWN PWTech LLC. | SHEET |
| APPROV. RICH HUNT | 5 OF 7 |

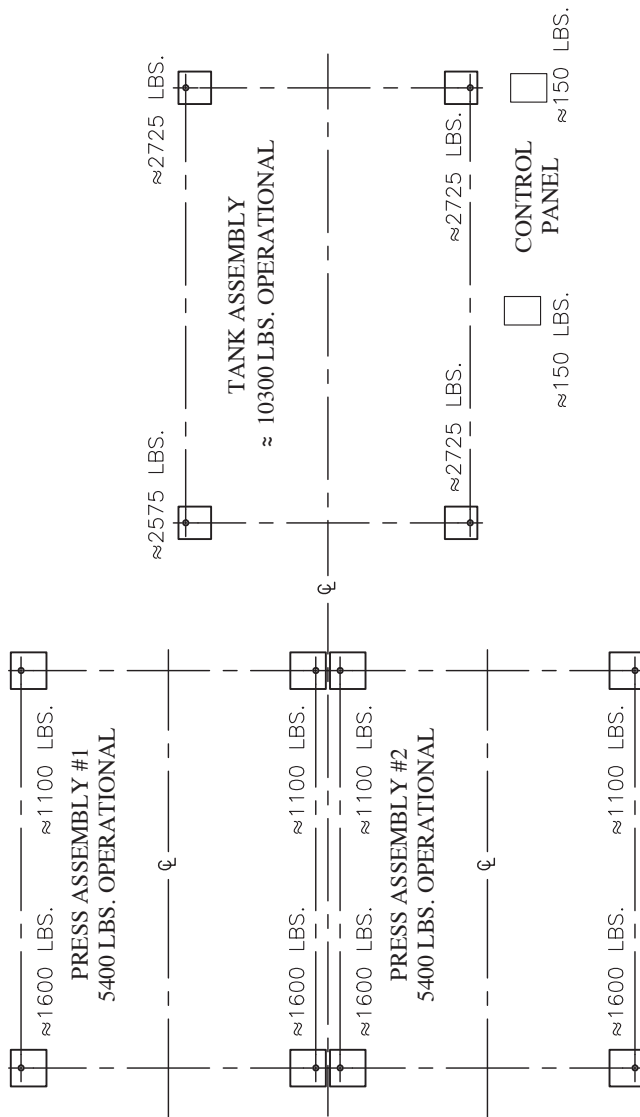

ANCHOR POINTS

DIMENSIONS: MM [INCHES]



VOLUTE DEWATERING PRESS
 ES-354 GA DRAWING
 ANCHORS PTS.

| | |
|----------------------|--------|
| JOB# PWT VDP ES-354 | SCALE |
| DATE 7 JANUARY, 2019 | NTS |
| DRAWN PWTech LLC. | SHEET |
| APPROV. RICH HUNT | 6 OF 7 |

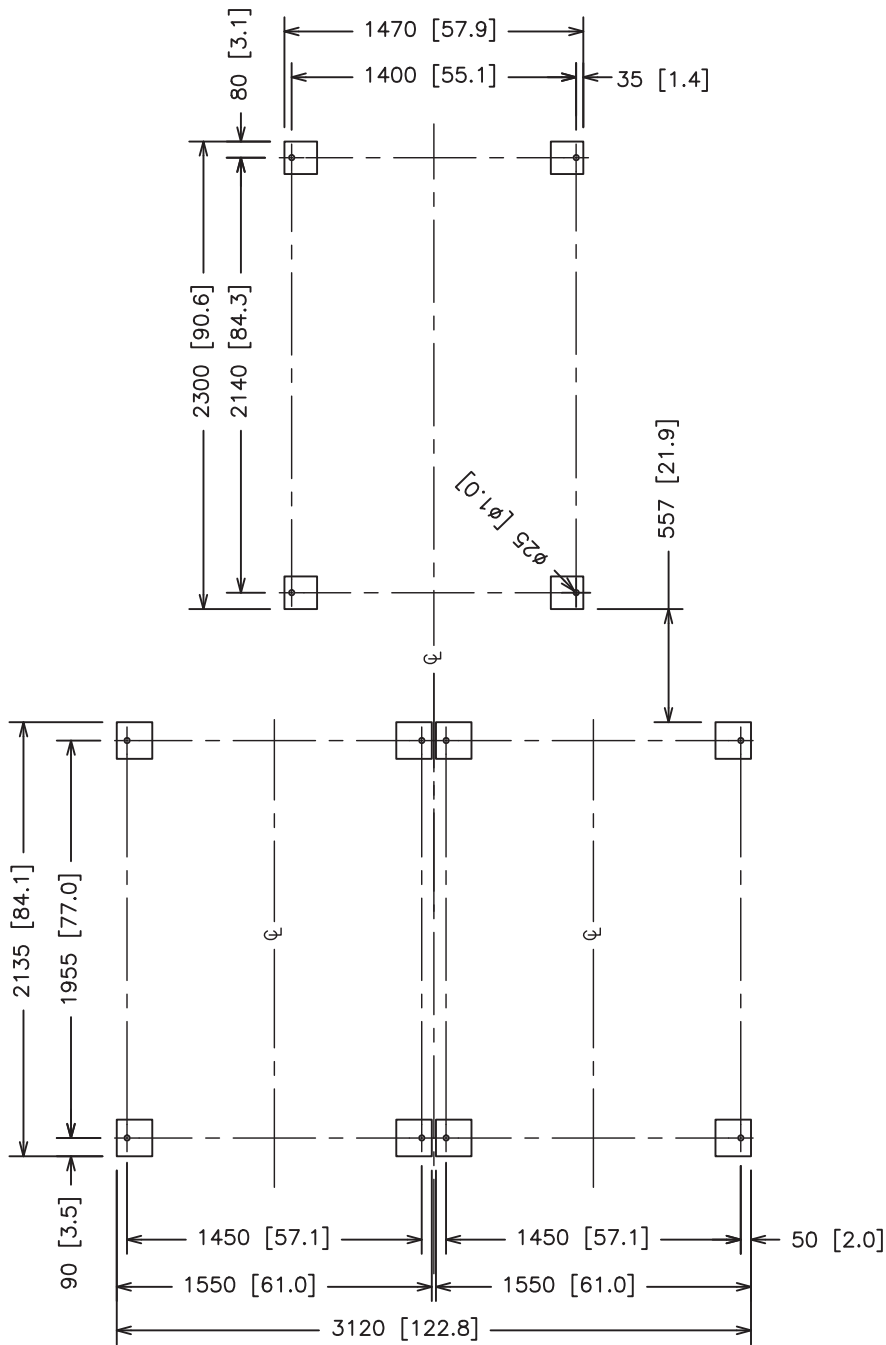

FOOTPRINT

DIMENSIONS: MM [INCHES]



VOLUTE DEWATERING PRESS
ES-354 GA DRAWING
FOOTPRINT

| | |
|----------------------|--------|
| JOB# PWT VDP ES-354 | SCALE |
| DATE 7 JANUARY, 2019 | NTS |
| DRAWN PWTech LLC. | SHEET |
| APPROV. RICH HUNT | 7 OF 7 |

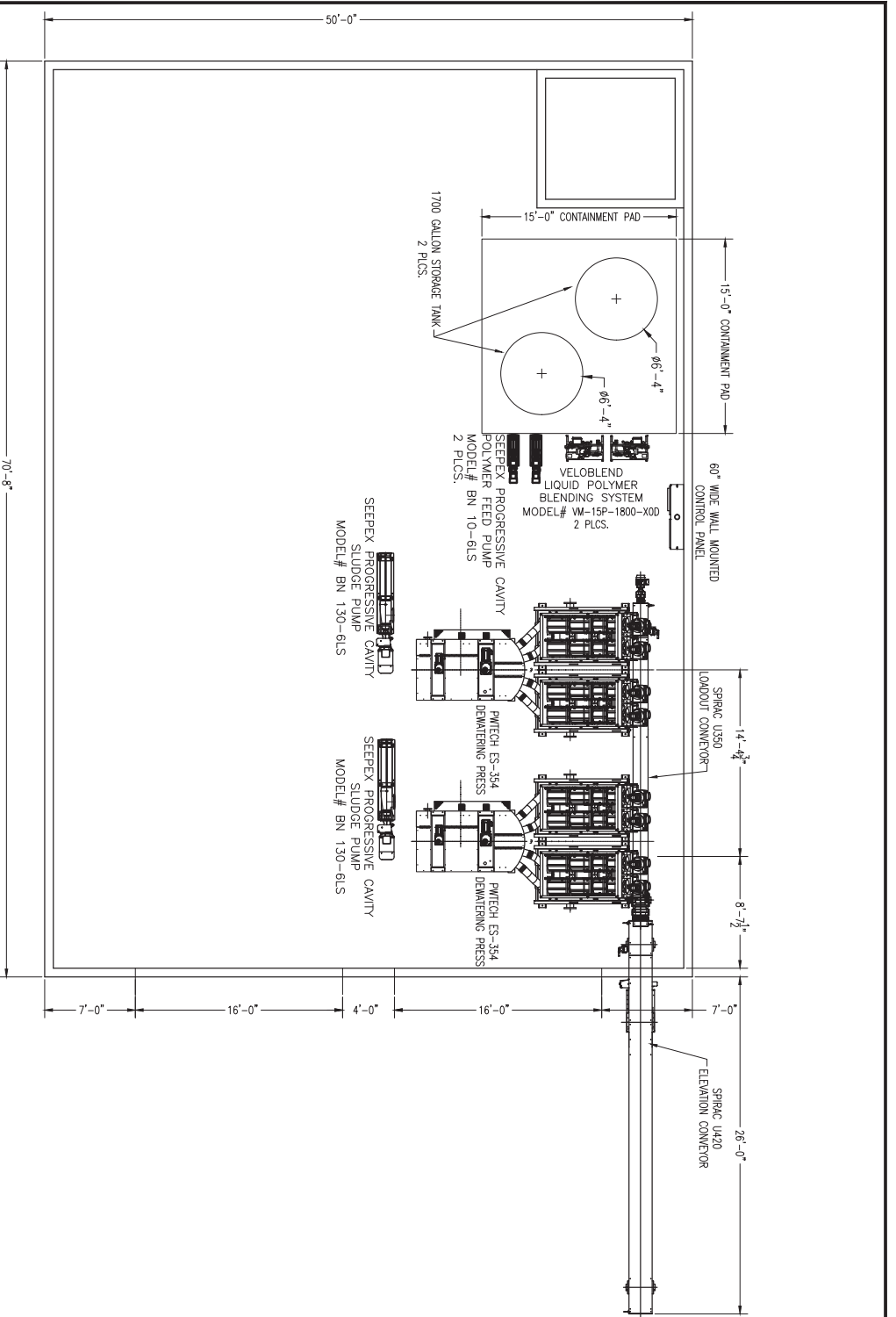

PWTech NOTES

- LAYOUT IS REPRESENTATIVE ONLY, TO DEMONSTRATE POTENTIAL INSTALLATION WITH EQUIPMENT FOOTPRINTS AS SHOWN.
- FINALIZED LAYOUT IS SUBJECT TO REVISION BASED ON DETAILED CONVEYOR, PLUMBING AND PRESS DESIGN, TAKING INTO ACCOUNT EXISTING BELT PRESS AND OTHER PRE-EXISTING EQUIPMENT.

REVISION AND ISSUE HISTORY

| REV | DATE | DESCRIPTION | DRN | CHKD |
|-----|----------|-----------------|-----|------|
| A | 10/17/19 | PROPOSED LAYOUT | JS | RH |
| B | 10/19/20 | PROPOSED LAYOUT | | RH |
| C | 11/02/20 | PROPOSED LAYOUT | | RH |

DRAWING APPROVAL

APPROVED: _____ DATE: 11/02/20 SIGNATURE: R. HUNT

PROPOSED LAYOUT

PWTech
PROCESS WASTEWATER TECHNOLOGIES
 Process Wastewater Technologies, LLC
 9004 Yellow Brick Road, Suite D
 Rosedale, Maryland 21237
 Tel. 410.238.7977
 Fax 410.238.7559
 www.PWTech.us

DRAWING TITLE:
 VOLUTE ES-354 DEWATERING PRESS
 SITE PROPOSED PLAN VIEW

PROJECT TITLE:
 POLE BRIDGE AWWT
 DEKALB COUNTY, GA.

PWT PROJECT NO.: VDPGA18065
SCALE: NTS
SHEET SIZE: 11 X 17

DRAWING NO.: 2201102_VDPGA18065_ES354_PRO_P
SHEET: 1 OF 1
REV: C

VELOBLEND MODEL: VM-0P-XXX-X

DILUTION WATER:

1. $\phi 1$ " FNPT INLET
2. X TO XX GPM FLOW RANGE

POLYMER:

1. $\phi 1$ " FNPT INLET
2. X.XX TO X GPH FLOW RANGE

SOLUTION:

1. $\phi 1$ " FNPT OUTLET

$\phi 15$ [$\phi 0.6$]
THRU, 4 TYP.

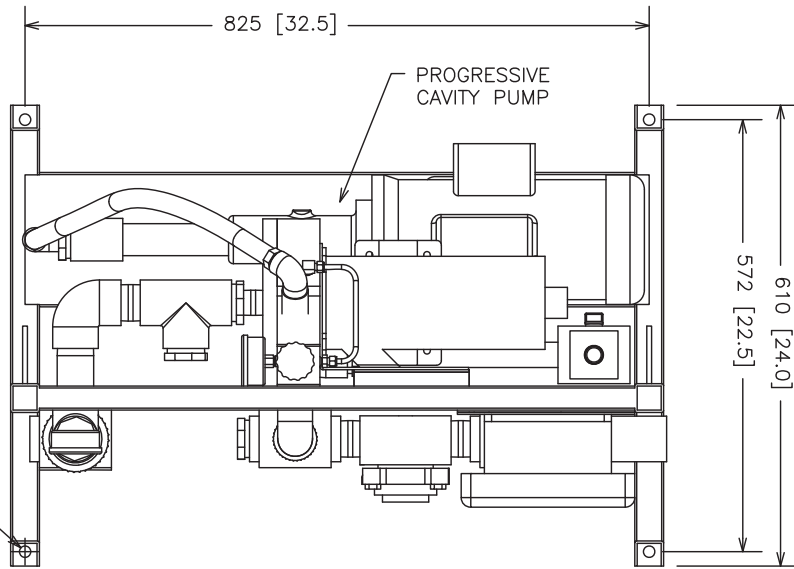

PLAN

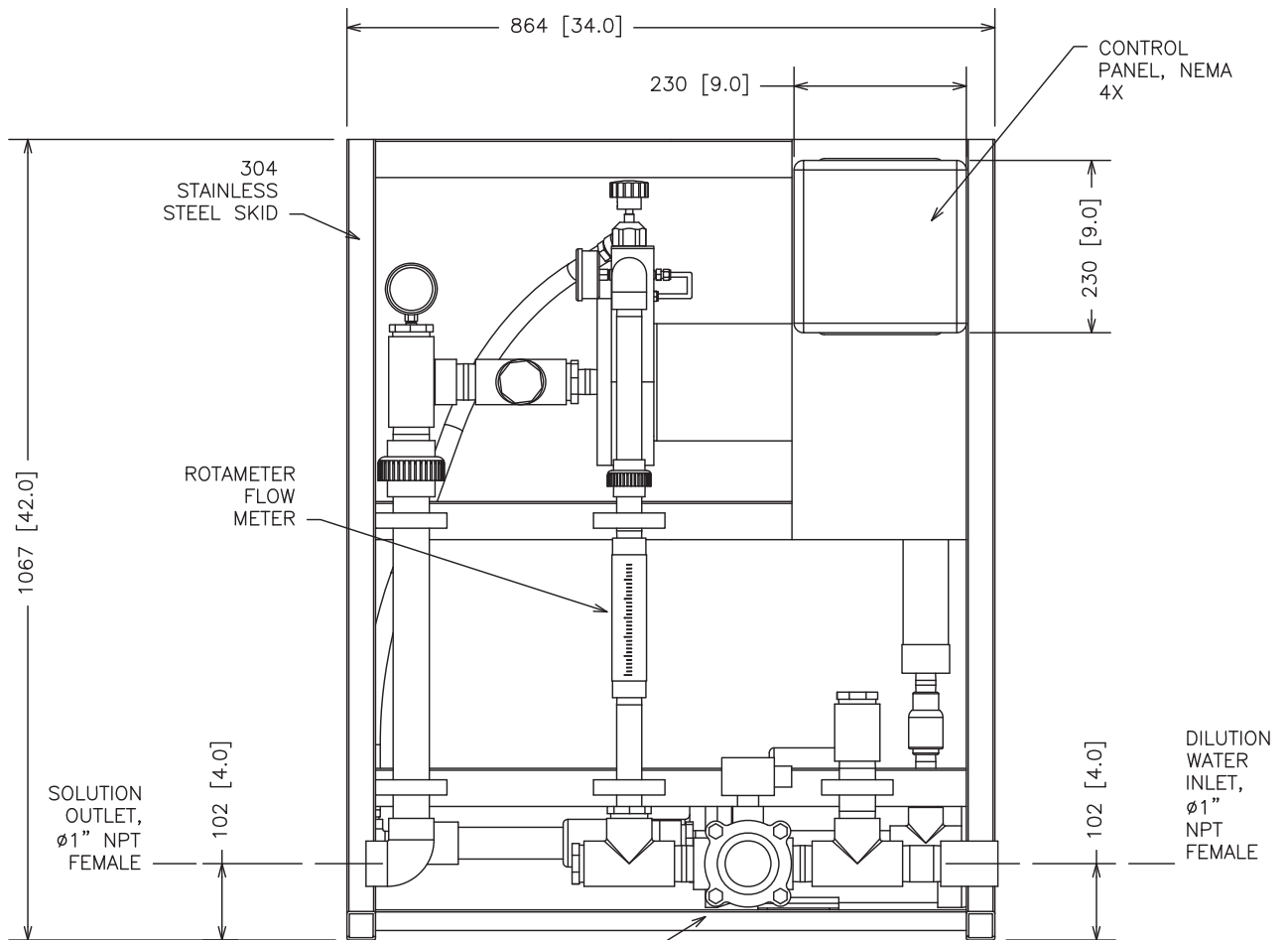

ELEVATION

DIMENSIONS: MM [INCHES]



**VELODYNE POLYMER PUMP
VM-P-XXX-X GA DRAWING
FRONT ELEVATION & PLAN**

JOB# PWT VM-P-XXX-X

DATE 23 MAR 2009

DRAWN PWTech Inc.

APPROV. ALEX DAVEY

SCALE

NTS

SHEET

1 OF 2

VELOBLEND_MODEL: VM-P-XXX-X

DILUTION WATER:

1. $\phi 1$ " FNPT INLET
2. X TO XX GPM FLOW RANGE

POLYMER:

1. $\phi 1$ " FNPT INLET
2. X:XX TO X GPH FLOW RANGE

SOLUTION:

1. $\phi 1$ " FNPT OUTLET

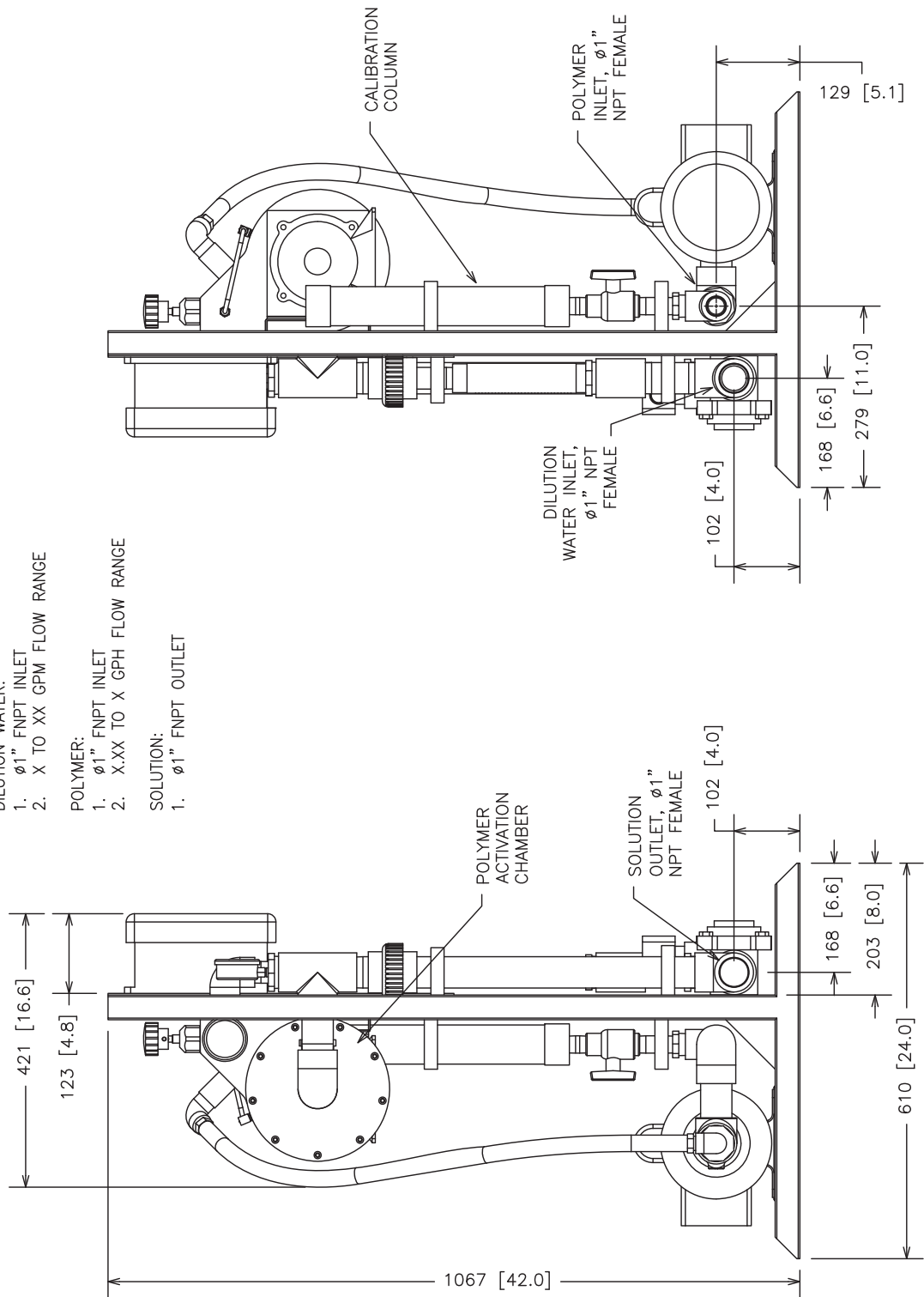

RIGHT ELEVATION

LEFT ELEVATION

DIMENSIONS: MM [INCHES]



VELODYNE POLYMER PUMP
 VM-P-XXX-X GA DRAWING
 RIGHT & LEFT ELEVATION

| | |
|---------------------|--------|
| JOB# PWT VM-P-XXX-X | SCALE |
| DATE 23 MAR 2009 | NTS |
| DRAWN PWTech Inc. | SHEET |
| APPROV. ALEX DAVEY | 2 OF 2 |

qty.: 2

Progressive cavity pump
BN 130-6LS / A1-C1-L8-F0-GA

Application data

| | |
|--------------------------|---------------------------------------|
| Conveyed product | 2.4% Sludge |
| Flowability | flowable |
| Viscosity | low viscosity (< 500 cP/mPas) |
| Solids content | 2.4 % |
| Size of solids | ≤ 2 mm |
| Density | unknown, 1 kg/dm ³ assumed |
| Product temperature | 32°F - 113°F |
| pH value | 5-9 |
| Kind of operation | continuous |
| Operating hours | 8 h/day |
| Location | indoor, dry atmosphere |
| Altitude of installation | up to 1000 m assumed |
| Surrounding temperature | normal (32-113°F) |

Performance data

| | Capacity | Pressure | Speed | |
|------------------------------------|--------------------------------|----------|---------|-----|
| | 66 USGPM | 15 psi | 45 rpm | min |
| | 330 USGPM | 15 psi | 210 rpm | max |
| Starting torque | 930 lb.ft | | | |
| Req. operating power at pump shaft | 8.8 HP | | | |
| Inlet pressure | flooded suction (up to 0,5bar) | | | |

Tolerances according to SEEPEX standards.

Materials and executions

| | |
|--|--|
| Installation | horizontal |
| Direction of rotation | counter clockwise (left) |
| Lantern - Design | with cover plates |
| Lantern - Material | EN-JL 1040 (gci-25) |
| Suction casing - Design | standard |
| Suction casing - Material | EN-JL 1040 (gci-25) |
| Pressure branch - Design | standard |
| Pressure branch - Material | EN-JL 1040 (gci-25) |
| Position of branch | position 1 |
| Suction connection | 8" ANSI B16.5 Class 150 RF |
| Pressure connection | 6" ANSI B16.5 Class 150 RF |
| Joint - Design | pin joint with joint sleeve, grease filled |
| Joint - Material | standard |
| Joint - Universal joint sleeve: material | NBR - Perbunan |
| Coupling rod - Design | standard |
| Coupling rod - Material | 1.4021 / AISI 420 |
| Rotor - Design | Smart Rotor-design |
| Rotor - Material | 1.0503 (C45) / AISI 1045 |
| Rotor - Coating | ductile chromium coating |
| Stator - Design | smart stator design |
| Stator - Material | NBR - Perbunan |

| | |
|-------------------------------|---|
| Shaft sealing | mechanical seal |
| Code | GA - single acting mechanical seal |
| Shaft diameter | 100 mm |
| Make | SEEPEX |
| Rotating/stationary seal face | SiC SiC |
| Elastomers | FPM |
| Spring | 1.4571 / AISI 316Ti |
| Metal parts | 1.4571 / AISI 316Ti |
| Type | GA Q1Q1 VGG |
| Casing - material | 1.4408 / ASTM A351 grade CF8M |
| Casing - connection standard | NPT |
| Plug-in Shaft - Design | standard |
| Plug-in Shaft - Material | 1.4021 / AISI 420 |
| Bolting - Design | standard |
| Painting - Number of colors | single-colored standard |
| Painting - Painted components | complete combination |
| Painting - Color | Standard Enamel (SEEPEX Blue) |
| Painting - Surface protection | std. surface protection C2 (NDFT 95 µm) |

Drive

| | | | |
|--|--|------------|------------|
| Type | Gear & Motor at freq. inv. (Inverter is not included) | | |
| Mounting position | B5 | | |
| Ratio (i) | 7.27 | | |
| | Norm | Min | Max |
| Speed | 127 rpm | 45 rpm | 210 rpm |
| Motor speed | 927 rpm | 328 rpm | 1523 rpm |
| Frequency | 32 Hz | 11 Hz | 52 Hz |
| Rated output | 25 HP | | |
| Rated speed | 1800 rpm | | |
| Mounting position | NEMA C-face/footed | | |
| Flange diameter | 11.25 | | |
| Shaft diameter | 1.875 | | |
| Starting | direct on frequency inverter | | |
| Efficiency class | IE1 | | |
| Terminal box position acc. to supplier | not specified | | |
| Cable entry position acc. to supplier | not specified | | |
| Voltage | 3 x 230/460 V | | |
| Frequency | 60Hz | | |
| Enclosure | TEFC | | |
| Thermal class | F | | |

The frequency inverter has to follow a linear U/f characteristic curve (constant torque).
It's essential to have a minimum overload capability of 150% for at least 3 seconds. (see technical data sheet)

Baseplate

| | |
|---------------|-------------------------------|
| Design | extended - with motor support |
| Material | steel, painted |
| GPU Type Code | B-ST-LS-EM |

Packing

| | |
|-------------------------------|--------------------|
| Type of packing | skid (US) |
| Type of transport | truck |
| Quantity of pumps per package | 1 pump per package |

Characteristic Curves
 Size
 130-6LS

SEEPEX.
ALL THINGS FLOW

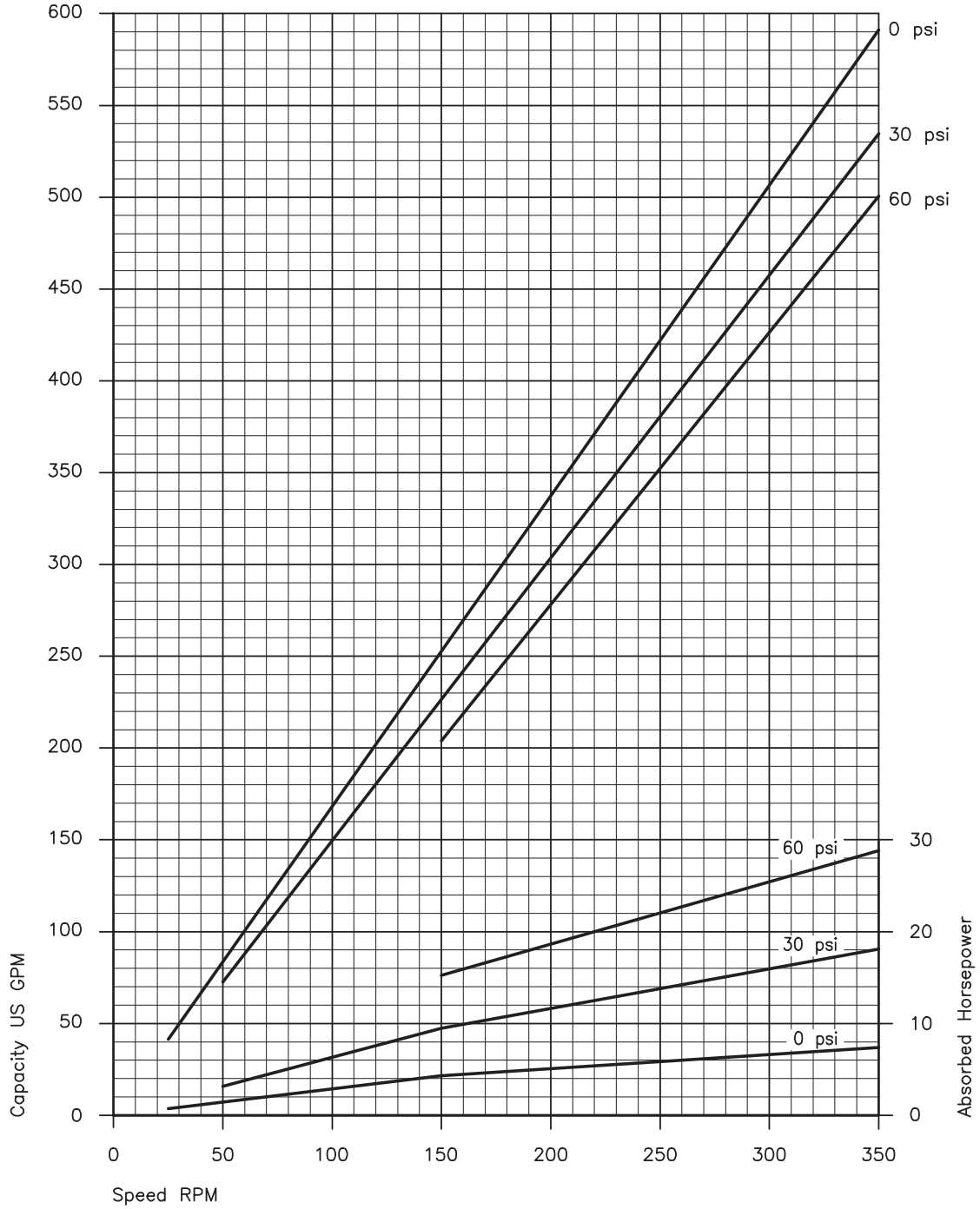

Values based upon water 68°F ; For notes on drive selection refer to PER

REVISION HISTORY

| REV | DESCRIPTION | DATE | APPROVED |
|-----|-------------|------|----------|
| | | | |

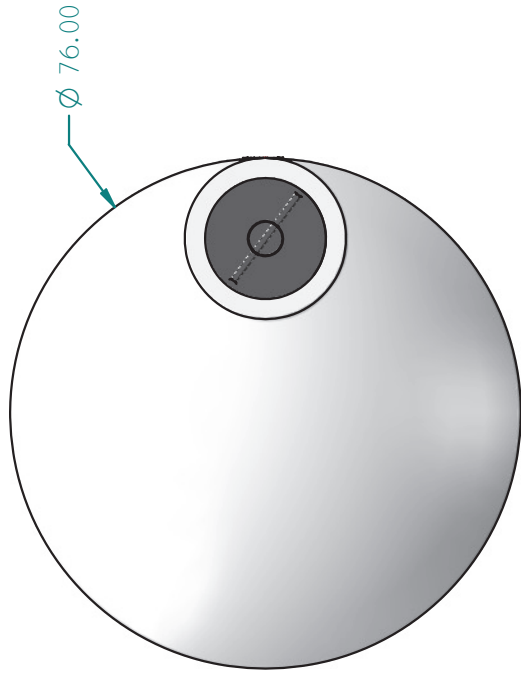

TOP VIEW

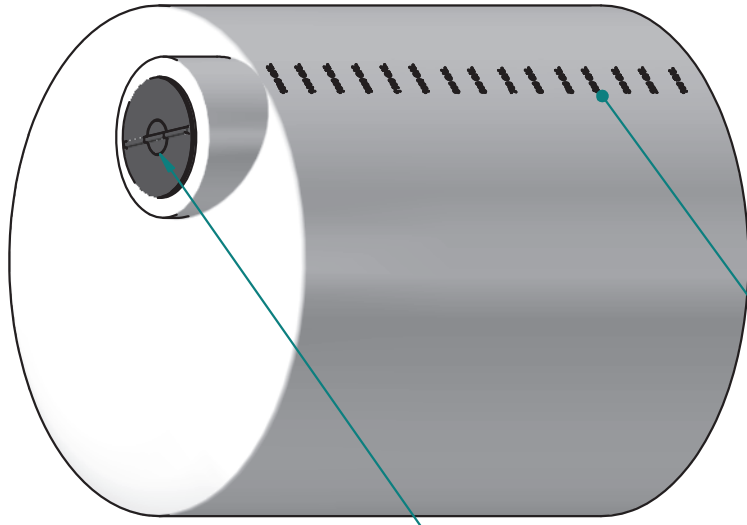

ISO VIEW

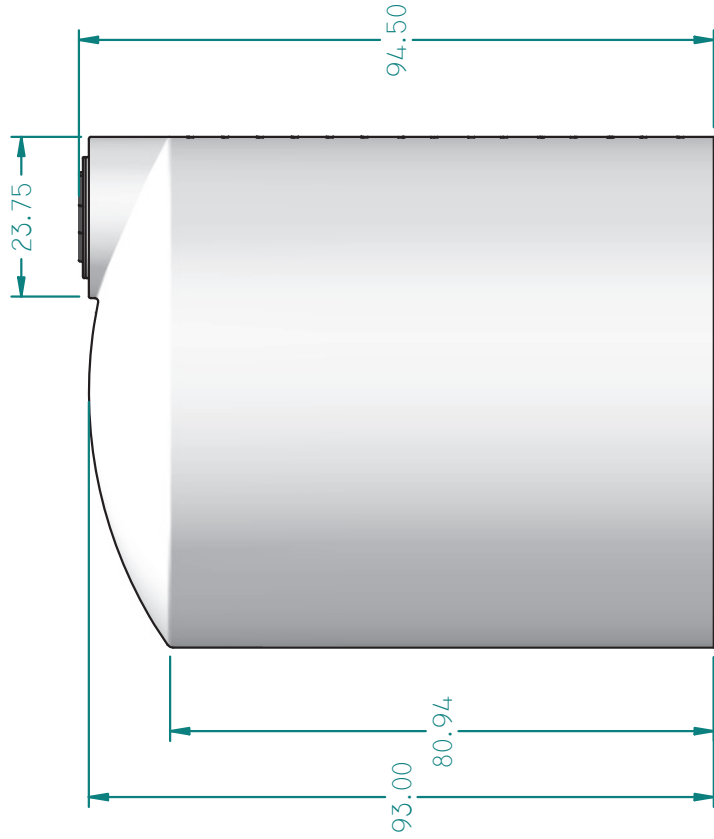

SIDE VIEW

WALL THICKNESS: 0.280"



16160 Hwy 27 Lake Wales, FL 33859

TITLE V-1700 GALLON TANK

| SIZE | MATERIAL | REV |
|------|---------------------|-----|
| A | LMDPE NATURAL (100) | |

FILE NAME: 901750.DFT

| PART # | WEIGHT | SHEET | OF |
|--------|-------------|-------|----|
| 901750 | 224.994 LBM | 1 | 1 |

| NAME | DATE |
|---------------|------------|
| DRAWN MNEGRON | 12/13/2008 |
| CHECKED | |
| ENG APPR | |
| MGR APPR | |

UNLESS OTHERWISE SPECIFIED
DIMENSIONS ARE IN INCHES
ANGLES ±0.5°
2 PL ±0.125" 3 PL ±0.060"



Fig. 1 - *valmetTS/PN16* & *valmetTS/PN100*

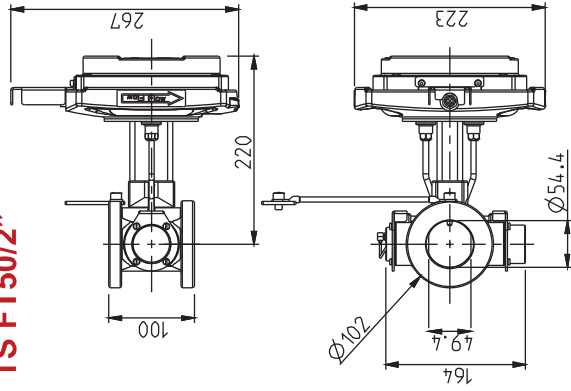

Fig. 2 - TCU, Transmitter Central Unit

Valmet TS: Main Dimensions

All dimensions are in mm (millimeters). 1 inch = 25.4 mm

TS FT50/2"



TS FT80/3"

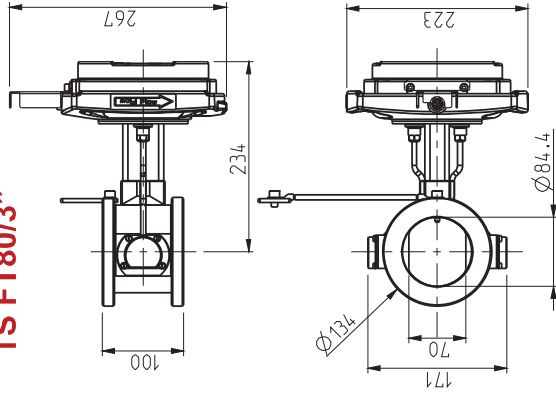

TS FT100/4"

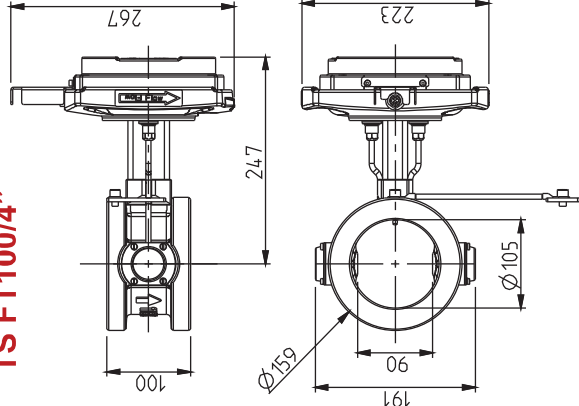

TS FT150/6"

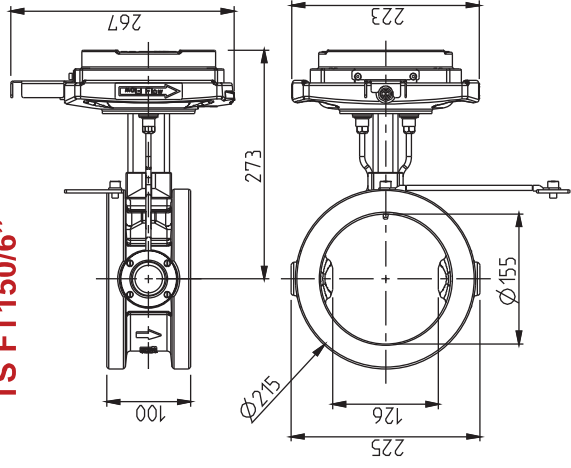

TS FT200/8"

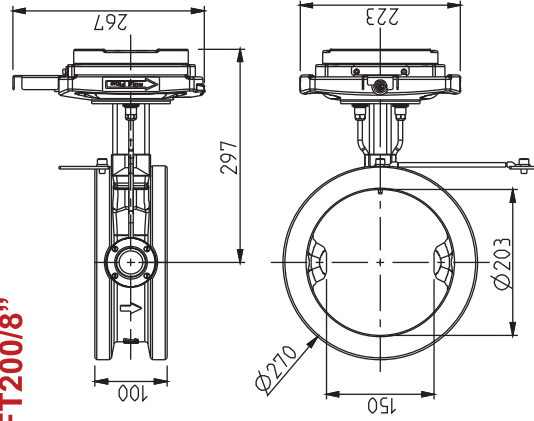

TS FT250/10"

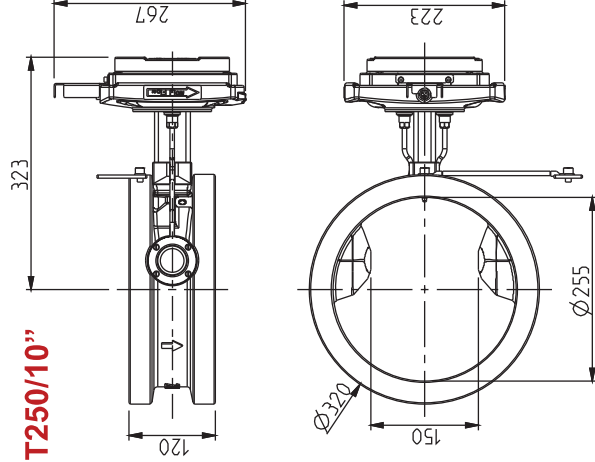

TS FT300/12"

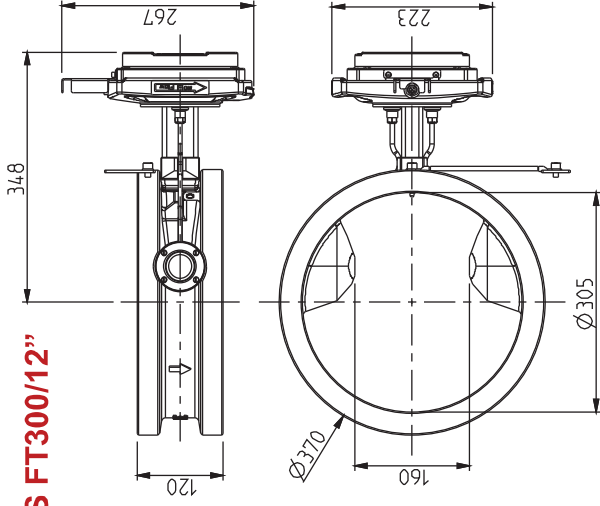

Valmet TS 100 bar Main Dimensions

Flange drill standards:

ANSI Class 600
 DI NPN 100
 JIS 63K

All dimensions are in mm (millimeters).
 1 inch = 2,54 mm

TS-100/4"

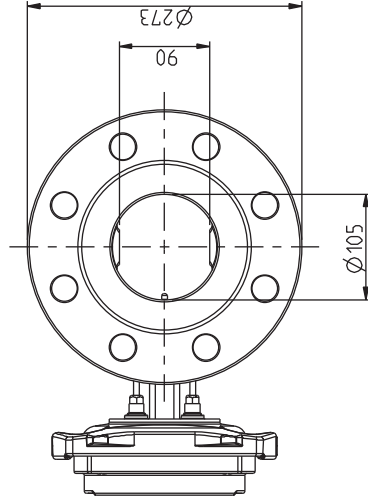
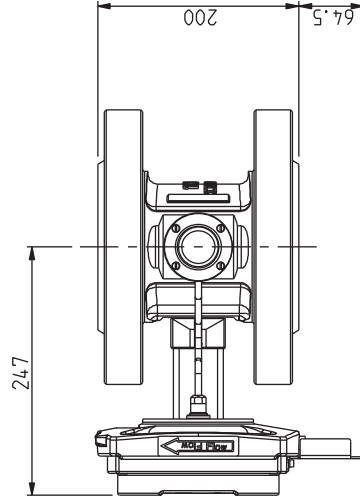

Total weight of sensor: 38 kg

TS-150/6"

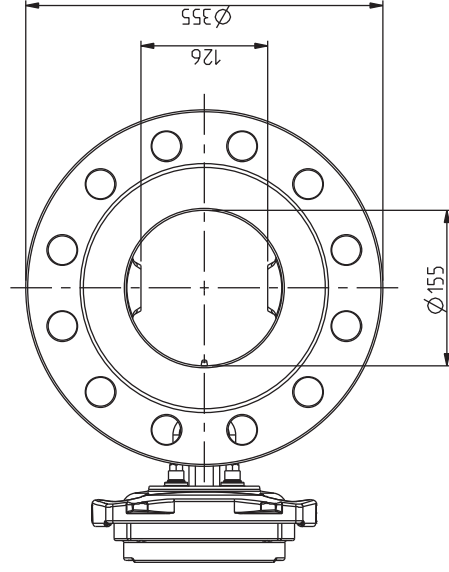
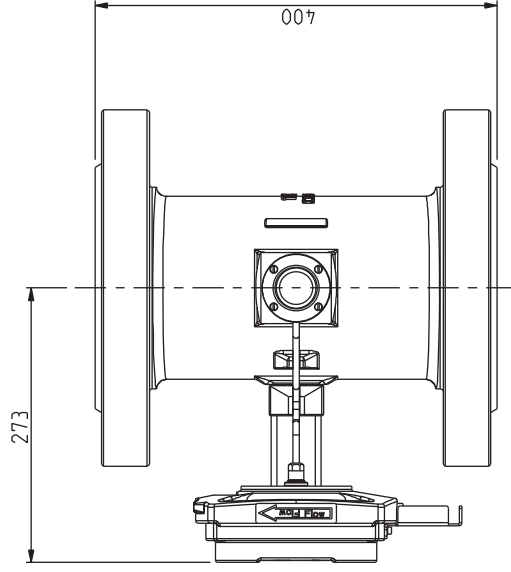

Total weight of sensor: 78 kg

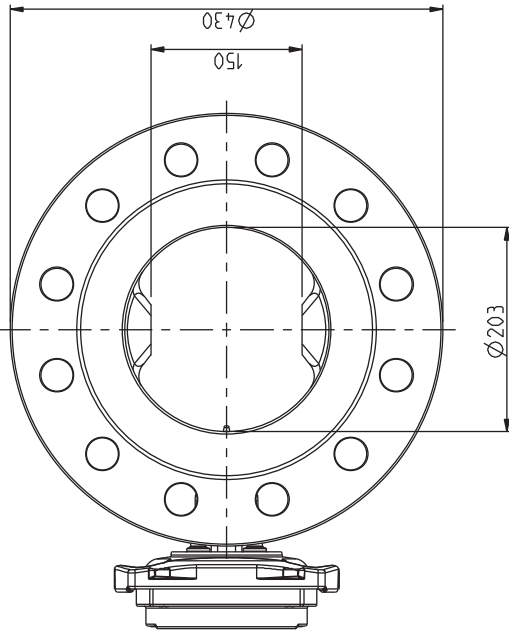
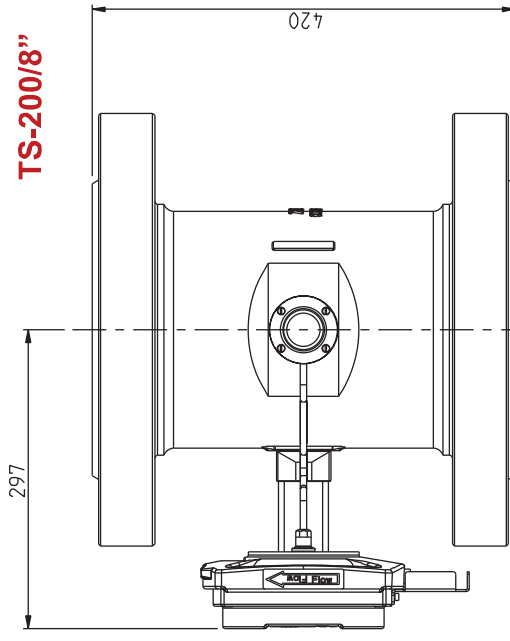

Total weight of sensor: 126 kg

Process Wastewater Technologies, LLC. Standard Terms and Conditions (Muni.)

These below terms and conditions shall exclusively govern the sale of all goods and related services by Process Wastewater Technologies, LLC. ("PWT") to Buyer.

Item 1. ACCEPTANCE

Buyer may accept the preceding offer by noting acceptance in the space provided on the preceding offer sheet, if such space is provided, or by written purchase order. No oral acceptance shall be effective. This writing is intended by the parties as a final expression of their agreement and, in conjunction with the accompanying signed offer or purchase order and the PWT Standard Limited Warranty ("PWT Standard Limited Warranty"), is intended as a complete and exclusive statement of the terms of their agreement. Acceptance or acquiescence in a course of performance rendered under this agreement shall not be relevant to determine the meaning of this agreement even though the accepting or acquiescing party has knowledge of the nature of the performance and opportunity for objection. No agent, employee or representative of PWT has any authority to bind the Seller to any affirmation, representation or warranty concerning the equipment, components or related services sold under this agreement, and unless an affirmation, representation or warranty made by an agent, employee or representative is specifically included within this written agreement, it has not formed a part of the basis of this agreement and shall not in any way be enforceable.

Item 2. CANCELLATION

Upon acceptance of the preceding offer, Buyer shall have no right to cancel this agreement or any part thereof, except under the conditions specified in this provision or otherwise agreed to in writing by both parties. Any cancellation by Buyer of this agreement must be in writing and shall be deemed effective upon receipt by PWT. In the event of cancellation by Buyer prior to the commencement of production of the goods specified under this agreement, Buyer shall pay PWT a cancellation charge equal to all of the costs incurred by PWT under this agreement up to the time of cancellation, plus fifteen percent (15%) of the full order amount. In the event that production of the goods under this agreement has commenced prior to cancellation, Buyer shall pay a cancellation charge equal to all of the costs incurred by PWT under this agreement up to the time of cancellation, plus an amount equal to the greater of: the value of the goods already completed under the agreement; or fifteen percent (15%) of the full order amount.

Item 3. PRICES

Unless otherwise stated in this offering, prices are F.O.B. the PWT manufacturing facility in Cincinnati, Ohio. Charges for on-site technical assistance performed by a factory technical representative are not included unless indicated.

Item 4. VALIDITY

Unless otherwise specified, the preceding offer is valid for acceptance for (30) thirty days and is subject to review thereafter. Prices may be extended beyond thirty (30) days only if confirmed in writing by PWT.

Item 5. PAYMENT TERMS

Ten percent (10%) of the purchase price under this agreement shall be invoiced net thirty (30) days upon approval of submittals and shop drawings; Eighty percent (80%) of the purchase price under this agreement shall be invoiced net

thirty (30) days upon shipping, or upon PWT's offer to ship. Five percent (5%) of the purchase price under this agreement to be invoiced net thirty (30) days upon delivery of O&M Manuals and the remaining five percent (5%) will be invoiced net thirty (30) days upon completion and/or performance of all related services under this agreement. Interest will be charged on the unpaid invoiced balance at the rate of one and a half percent (1½%) per month for any amount received after thirty (30) days from the date of invoice. Any collection costs and/or attorney fees incurred by PWT in order to collect payment due will be invoiced to the Buyer, and Buyer agrees to pay said costs.

Item 6. FEES AND TAXES

Buyer shall pay directly or reimburse PWT for payment of any and all applicable customs, sales, use, excise or other fees and taxes associated with the production and delivery of goods under this agreement. Buyer is responsible for and bears the risk of establishing, if applicable, a valid exemption from any tax, and shall indemnify, defend and hold PWT harmless for any loss, cost or expense relating to any such exemption.

Item 7. DELAYED SHIPPING

If Buyer specifies a shipping date more than one (1) year from the date of acceptance of the preceding offer, the price stated in the preceding offer for the same goods shall be increased by a figure of six percent (6%).

Item 8. FINANCIAL RESPONSIBILITY OF BUYER

If at any time before shipment, Buyer's financial ability to pay becomes impaired or unsatisfactory, PWT shall have the right to require Buyer to make payment in full before shipment. In addition, if at any time before shipment, any proceeding is brought by or against Buyer under the bankruptcy or insolvency laws, PWT shall have the right to cancel this contract and Buyer shall pay PWT a cancellation charge equal to all of the costs incurred by PWT up to the time of termination, plus fifteen percent (15%) of the purchase order amount.

Item 9. SHIPPING

Unless otherwise specified, all equipment and components will be shipped in one lot by the lowest cost method at the discretion of PWT. Any additional shipping requests by Buyer may be subject to additional shipping and handling charges. All shipments shall be F.O.B. the PWT manufacturing facility in Cincinnati, Ohio. Delivery to the carrier shall constitute delivery to Buyer for purpose of transfer of risk of loss or damage in transit, and any delivery deadlines specified in this agreement. Buyer is responsible for obtaining any desired cargo insurance and shall pursue any loss or damage claims solely with the carrier.

Item 10. DELIVERY SCHEDULE

Unless otherwise specified, delivery dates under this agreement are approximate, and failure to meet an exact delivery date shall not constitute a breach of this agreement unless delivery is not effected within a reasonable time after the specified delivery date.



Item 11. INSPECTION

Inspection by Buyer or Buyer's representative of the goods specified under this agreement will be permitted prior to shipment at the PWT manufacturing facility in Cincinnati, Ohio, at a time mutually agreeable to both parties. Inspection will be allowed only inasmuch as such inspection does not unreasonably interfere with PWT's production work flow. Complete details of any requested inspection must be submitted to PWT in writing, at least two weeks in advance of the requested inspection date. Any inspection under this provision must be completed prior to shipment of any goods under this agreement.

Item 12. OFFER BASIS

This agreement is exclusively based upon drawings and specifications in the possession of PWT at the time of this agreement. PWT expressly reserves the right to modify the price and other terms of this agreement as reasonable, should additional drawings, documents, or other addenda be required to produce or deliver the goods and/or services provided under this agreement.

Item 13. LIMITED WARRANTY

PWT's warranty liability under this agreement is limited to the terms listed in the PWT Standard Limited Warranty that accompanies these Terms and Conditions, and is incorporated herein by reference. No other warranty, express or implied, is made with respect to the goods and/or services provided under this agreement.

Item 14. MEET AND CONFER

The parties shall amicably work together to negotiate and resolve any controversy or dispute arising out of, or in connection with this agreement or its interpretation, performance or nonperformance or breach thereof. In particular, in the event of a disagreement, the parties shall meet and confer and attempt in good faith to resolve their differences. At the request of the aggrieved party, a face-to-face meeting between decision-makers of the parties shall be arranged at the offices of the non-aggrieved party. Such a meeting shall occur within fourteen days of the delivery of the written request of the aggrieved party, unless otherwise agreed by the parties.

Item 15. ARBITRATION

If, after meeting and conferring as provided under this agreement, the parties are unable to resolve their differences, any disputes shall be settled by binding arbitration in accordance with the following procedures:

- (a) The Arbitration shall be conducted in accordance with the Commercial Arbitration Rules of the American Arbitration Association ("AAA") in effect at the time of the arbitration, except as may be modified herein or by mutual agreement of the parties. The location of the arbitration shall be Baltimore, Maryland or Towson, Maryland.
- (b) The arbitration shall be conducted by one arbitrator jointly selected by the parties. If the parties are unable to agree upon an arbitrator after thirty (30) days, the arbitrator shall be selected under AAA rules.
- (c) The award shall be in writing and shall state the reasons for the award and shall be final and binding on the parties. The award may also include an award of costs, including reasonable attorneys' fees and disbursements. Judgment upon the award may be entered by any court having competent jurisdiction over the parties or their assets.

Item 16. GOVERNING LAW

All disputes and matters arising under, in connection with, or incidental to this contract shall be litigated, if at all, in and before the Circuit Court of Baltimore County, Maryland, USA to the exclusion of other courts of other states, the United States or other countries and to the exclusion of other venues. The parties expressly consent to the exclusive jurisdiction of this court and agree that this venue is convenient and not to seek a change of venue or to dismiss this action on the grounds of *forum non conveniens*, and not to remove any litigation from that court to a federal court. This Agreement shall be construed in accordance with and governed by the substantive laws of the State of Maryland, to the extent state law applies. An action for breach of this agreement must be commenced within two (2) years after the cause of action has accrued.

Item 17. WAIVER AND MODIFICATION

No waiver by either party of any breach, default or violation of any term, warranty, representation, agreement, covenant, condition or provision of this agreement shall constitute a waiver of any subsequent breach, default, or violation of the same or other term, warranty, representation, agreement, covenant, condition or provision. No modification, amendment, extension, renewal, rescission, termination or waiver of any of the provisions contained in this agreement, or any future representation, promise or condition in connection with the subject matter of this agreement, shall be binding upon either party unless in writing and signed by both parties.

Item 18. SEVERABILITY

Any provision of this agreement which is invalid, prohibited or unenforceable in any jurisdiction shall, as to such jurisdiction, be ineffective solely to the extent of such invalidity, prohibition or unenforceability without invalidating the remaining provisions hereof, and any such invalidity, prohibition or unenforceability in any such jurisdiction shall not invalidate or render unenforceable such provision in any other jurisdiction.

Item 19. ASSIGNMENT AND DELEGATION

Neither party to this agreement shall have the right to assign or delegate its interest in or obligations under this Agreement without the prior written consent of the other party, which shall not be unreasonably withheld. The merger, acquisition, reorganization or other restructuring of PWT shall not constitute an assignment under the terms of this agreement provided the surviving entity has assumed all of the obligations of PWT under this agreement. The transfer of any rights under this agreement from PWT to any entity controlled by or affiliated with PWT shall not constitute an assignment under the terms of this agreement provided PWT retains all of its obligations under this agreement. The rights and obligations of the parties to this Agreement shall be binding upon, and enforceable by their respective heirs, successors and permitted assigns.

PWT LLC Standard Limited Warranty

Item 1. LIMITATION OF LIABILITY

The only warranty which PWT LLC ("PWT") makes is that warranty which is set forth in the preceding agreement and which is further detailed below:

THE GOODS SPECIFIED UNDER AGREEMENT WITH PWT ARE PROVIDED "AS IS" AND PWT DOES NOT MAKE ANY OTHER EXPRESS WARRANTIES OR ANY IMPLIED WARRANTIES WITH RESPECT TO THESE GOODS AND/OR RELATED SERVICES, INCLUDING ANY IMPLIED WARRANTY OF MERCHANTABILITY OR OF FITNESS FOR A PARTICULAR PURPOSE OR USE.

In addition, PWT does not assume and expressly disclaims any liability for (i) any SPECIAL, INDIRECT, INCIDENTAL OR CONSEQUENTIAL DAMAGES which anyone may suffer as a result of the sale, delivery, service, use, or loss of use, of any goods and/or services provided by PWT, or (ii) any charges or expenses of any nature which are incurred without the express written consent of PWT. In particular, PWT does not warrant that any goods provided are free from any claim of any third person by way of infringement or the like, and PWT expressly disclaims any liability for any claim of infringement or the like that may result from the sale, delivery, service, use, or loss of use of any goods and/or services provided by PWT.

PWT's obligation under this warranty is expressly limited to the repair or replacement of any part or parts that are proved to the satisfaction of PWT to have failed prematurely or because of a fault in workmanship or materials.

PWT's total liability under this warranty or in connection with any claim involving any goods or services is expressly limited to the purchase price of the goods and/or services in respect of which damages are claimed.

Item 2. DEFECTS WARRANTY

PWT warrants that the goods manufactured by PWT shall be free from defects in material and workmanship for the shorter period of: (i) twelve (12) months from the date of start-up; or (ii) eighteen (18) months from the delivery of the specified goods.

PWT's liability under this warranty or in connection with any other claim relating to goods manufactured and delivered by PWT is limited to the repair, or at our option, the replacement or refund of the purchase price, of any products or parts or components which are returned to PWT freight prepaid, and which PWT determines, in its discretion, are defective in material and workmanship. Products or parts or components thereof which are repaired or replaced by PWT will be returned to the buyer freight collect.

Item 3. PRODUCTS OF OTHER MANUFACTURERS

PWT makes no warranty with regard to any products not manufactured by PWT, including but not limited to electrical components or equipment and other prime movers.

Item 4. TYPES OF DAMAGES AND CLAIMS FOR WHICH PWT LLC IS NOT RESPONSIBLE

The following non-exclusive list of items are specifically not covered by the PWT Standard Limited Warranty and, in the event of their occurrence, will render the PWT Defects Warranty null and void:

- defects which are caused by improper installation, improper or abnormal use or operation, or improper storage or handling;
- defects caused by the failure of the buyer or user to perform and log normal preventative maintenance;
- defects caused by the use of replacement parts not approved in writing by PWT;
- defects caused by repairs by persons not authorized in writing by PWT;
- defects caused by modifications or alterations made by the buyer or user;
- any damage to our any product occurring while it is in the possession of the buyer or user.

Item 5. EQUIPMENT SAFETY PARAMETERS:

With respect to operation of the equipment, it is the responsibility of the buyer to define and provide any safety device(s) or associated safety device(s) (other than that which is ordinarily furnished by PWT) which may be necessary and/or required, and to establish safety procedures and operational instructions to safeguard the operator(s) during maintenance, cleaning, or any use of the equipment whatsoever, and to subsequently ensure that the equipment is operated in conformance with all applicable safety procedures, laws, regulations and instructions.

It is also the responsibility of the buyer to enforce all safety regulations and operational instructions and to maintain the equipment in a safe condition (e.g., guards in place; warning, caution and/or important labels affixed; electrical boxes secure; interlocks operational; etc.). In particular, all warning, caution and/or important labels must be maintained in a readable condition, and if necessary, replaced with new labels.

Additionally, as the nature of the equipment does not always make it possible to fully prevent operator access from rotating components, maintenance or cleaning of any nature must not be performed on the equipment without first disconnecting all power.

Item 6. OPERATOR SAFETY COMPLIANCE:

Buyer warrants and agrees that because it has sole control over the equipment, it shall be solely responsible for safety compliance. Operator access and use of equipment, and full compliance with all provisions of the Operator Safety section of PWT Instruction Manuals are essential and the user's responsibility; the provisions of that section being expressly incorporated herein.



Installation of two (2) Volute Dewatering Presses, Conveyors and Appurtenances at the Pole Bridge AWWT in DeKalb County, GA. Our work will require unimpeded access to the site for use of a 10,000 pound telehandler or forklift to unload and set the equipment. Our proposal includes:

- Unloading of proposed materials
- Concrete leveling piers under Tank Assemblies and Dual Press Assemblies Anchor Points (A total of twenty-four (24) leveling pier's will be poured under the legs of the presses and tanks, each pier will have reinforcing steel epoxied into the existing concrete base slab and anchors for the equipment into the piers)
- Concrete Pad for Containment Area
- Concrete Pad for Elevation Conveyor Support
- Concrete Housekeeping pads for Sludge Pumps
- Concrete Housekeeping pads for Polymer Blending System Skid
- Concrete Housekeeping pads for Polymer Pumps
- All concrete pads will have reinforcing dowels drilled into the existing concrete base slab for support
- Stainless steel anchor's at specified anchor point locations
- 4" Ductile iron pipe sludge feed from common location to Seepex Feed Pumps
- Isolation Plug Valve on suction side of Sludge Feed Pumps
- Concrete pipe supports for sludge feed line to feed pumps
- Wall core with linkseals for sludge feed line to pumps
- 4" Ductile Iron pipe sludge feed from Seepex Feed Pumps to inlet at Flocculation Tank
- Check Valve on discharge side of Sludge feed Pumps
- Galvanized stanchion pipe supports for sludge feed line from feed pumps to Flocculation Tank
- 6" Ductile Iron pipe Filtrate Drain from Press Assembly to one (1) common point outside building (location to be determined by owner, no concrete slab removal inside the building is included)
- Concrete pipe supports for Filtrate Drain line
- Wall core with linkseals for Filtrate Drain line
- PVC water line to Polymer makeup area
- PVC water line to water inlet connection at Press
- Polymer line piping related to tanks, makeup system, pumps and press unit
- Painting of Ductile Iron Piping with Epoxy Coatings
- Installation of two (2) PW Tech Volute Dewatering Presses
- Installation of two (2) Velodyne Polymer Preparation Units
- Installation of two (2) Seepex Sludge Feed Pumps
- Installation of two (2) Seepex Polymer Feed Pumps
- Installation of two (2) Sludge Flowmeters
- Installation of two (2) Polymer Feed Flow meters
- Installation of two (2) Polymer Day Tanks
- Installation of one (1) Containment Wall System with Liner
- Installation of one (1) Spirac Loadout Shaftless Screw Conveyor
- Installation of one (1) Spirac Elevation Shaftless Screw Conveyor
- Installation of one (1) Magnetic Flow Meter
- Installation of one (1) Total Solids Analyzer
- Installation of one (1) Dry Solids Cake Analyzer

- Installation of electrical systems including:
- 2- 40 Amp, 480 Volt Circuits from existing service to Volute Control Panels. We have assumed that the existing service is sufficient size for this additional load.
- Volute System Component wiring from Main Control Panel to field equipment for two systems including:
 - o Sludge Feed Pump (480 Volts)
 - o Magnetic Flow Meter (120 Volts & 4-20MA Signal)
 - o Sludge Conveyor (480 Volts and E-STOP control circuit)
 - o Polymer System (7- 120 Volt Control Wires & 4- 90VDC Control Wires)
 - o Total Solids Metes (120 Volts and 4-20MA Signal)
- No local disconnect switches are included with this proposal. We have assumed the system doesn't require them with this design
- Conduit shall be Aluminum rigid Conduit with type THHN Stranded Copper Conductor's
- Startup assistance
- Overhead/Supervision/Insurance and Taxes

Our proposal specifically excludes:

- System Design or Performance Guarantee
- Performance/Payment Bonds
- Building Permits or Electrical Permits
- Davis Bacon Wager Rates
- AIS Requirements
- Electrical drawings and Electrical Engineer stamp
- Pipe Insulation or Heat Trace Materials
- Mechanical Equipment
- Any valves/instrumentation other than what is listed in PW Tech's proposal of October 24, 2019
- We have assumed the Model 354 Presses will come with the rear mounted Control Panels on the pre-wired equipment skids
- Electrical drawings and Electrical Engineer stamp
- Additional building lighting or outlets (assumed as existing)
- SCADA System connections